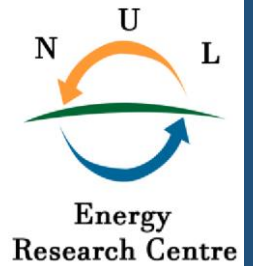






**National University of Lesotho**



# **Modelling and optimization of micro grids for rural areas in Lesotho (component sizes for technical and economic feasibility)**

*Thabo Samuel Fonya*

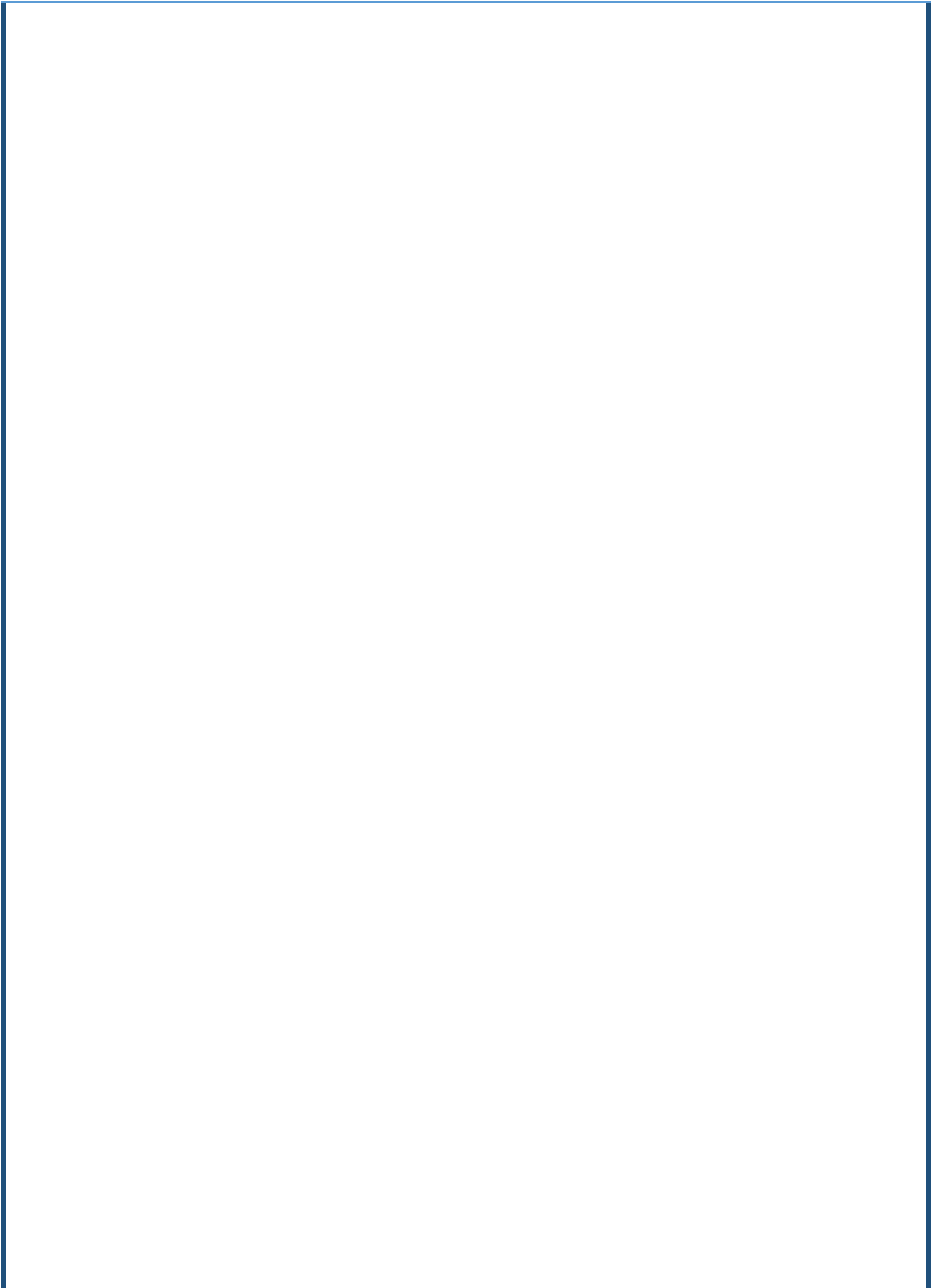
A dissertation submitted in partial fulfilment of  
the requirements for the degree of

***Master of Science in Sustainable Energy***

Offered by the

**Energy Research Centre**  
Faculty of Science & Technology

May 2021





# Table of Contents

Abstract.....	vi
Chapter 1: Introduction.....	7
1.1 Background .....	7
1.2 Problem statement .....	10
1.3 Justification of the study .....	11
1.4 Research objectives .....	12
1.5 Research Questions .....	12
1.6 Research scope .....	13
1.7 Dissertation outline .....	13
Chapter 2: Literature Review.....	13
2.1 Water .....	17
2.2 Solar radiation .....	20
2.2.1 Irradiance .....	20
2.2.2 Solar cell .....	23
2.2.3 Solar cell (PV) electrical characteristics .....	25
2.3 Wind.....	27
2.3.1 Generation of wind power .....	29
2.4 Hybridization in a micro grid .....	31
Chapter 3: Methodology.....	32
3.1 Daily Energy Consumption (Load Profile) of Ha Lehloara village .....	32
3.2 System Design to meet energy demand of Ha Lehloara village .....	33
3.2.1 Hydro power micro grid .....	33
3.2.2 Solar micro grid .....	34
3.2.3 Wind micro grid .....	37
3.2.4 Hybrid Options .....	37
3.3 Economic model of the designed system .....	43
3.3.1 Cost of Energy (LCOE) .....	44
3.3.2 Net Present Value .....	44
3.3.3 Net Present Cost .....	45
3.3.4 Salvage value .....	46
3.3.5 Payback Period .....	47
3.3.6 Internal rate of return.....	47
3.4 Implementation of system using HOMER .....	47
3.4.1 Modelling of system configuration.....	48
3.4.2 Optimisation of the results.....	48
Chapter 4: Results and Discussion .....	50

4.1 Results for Energy Consumption (Load Profile) of Ha Lehloara village.....	50
4.2 Hydro power micro grid.....	54
4.2.1 Water resource for hydropower micro grid .....	54
4.3 Hydro/diesel generator system configuration.....	58
4.3.1 Diesel generator .....	58
4.4 Solar micro grid.....	61
4.4.1 Solar irradiance.....	62
4.4.2 Temperature.....	62
4.4.3 Results of Solar micro grid .....	63
4.5 Solar/Generator system configuration.....	71
4.5.1 NPV, IRR and Payback Period .....	74
4.6 Wind micro grid .....	75
4.6.1 Wind speed .....	75
4.6.2 Wind turbine .....	76
4.7 Wind/Generator system configuration .....	78
4.8 Solar/wind system configuration.....	81
4.9 Solar/Wind/Generator system configuration.....	84
4.9.1 NPV, IRR and Payback Period .....	87
4.9.2 Sensitivity Analysis Results .....	87
4.10 Solar/hydro hybrid micro grid system configuration .....	88
4.11 Solar/hydro/diesel generator system configuration.....	91
4.12 Solar without storage/hydro system configuration.....	94
4.13 Solar/hydro/wind system configuration .....	96
4.14 Solar/ Hydro/Wind/Generator system configuration .....	99
4.15 DISCUSSIONS .....	102
4.15.1 Analysis of different system configurations .....	102
4.15.2 Analysis of two best optimal system configurations.....	105
Chapter 5: Conclusions and Recommendations .....	110
References.....	111

## Table of Figures

<b>Fig 1.1</b> Ha Lehloara village .....	9
<b>Fig 1.2</b> Malibamatšo river at Ha Lehloara village .....	9
<b>Fig 2.1</b> Micro grid development cost sharing in USA .....	16
<b>Fig 2.2</b> Global investment in renewable power from 2005 to 2017 .....	16
<b>Fig 2.3</b> Clean energy investment from 2004 to 2014 .....	17
<b>Fig 2.4</b> Wind and solar power: (a) global investment and (b) worldwide power generation ..	17
<b>Fig 2.5</b> Turbine selection graph as a function of net head, discharge and power .....	19
<b>Fig 2.6</b> Layout of SHHP .....	20
<b>Fig 2.7</b> Micro hydro power station generating from weir .....	20
<b>Fig 2.8</b> Turbines Efficiency Curves .....	21
<b>Fig 2.9</b> Beam/direct and diffuse radiations .....	22
<b>Fig 2.10</b> Angles for determining sun’s position .....	22
<b>Fig 2.11</b> Photo-generation of Charge Carriers during Photovoltaic effect .....	25
<b>Fig 2.12</b> PV Module .....	25
<b>Fig 2.13</b> PV Array.....	26
<b>Fig 2.14</b> PV I-V and P-V characteristics of a typical panel.....	26
<b>Fig 2.15</b> The PV solar cell I–V characteristic curve .....	27
<b>Fig 2.16</b> Global cumulative installed solar photovoltaics capacity .....	27
<b>Fig 2.17</b> Global energy mix in 2018 .....	28
<b>Fig 2.18</b> Global wind energy generation capacity .....	28
<b>Fig 2.19</b> Global increment in wind energy .....	29
<b>Fig 2.20</b> Wind speed frequency distribution.....	30
<b>Fig 2.21</b> Power curve of the hypothetical wind turbine model.....	32
<b>Fig 2.22</b> Hybridization of wind, PV and hydro .....	32
<b>Fig. 3.2</b> Hydropower micro grid supply to Ha Lehloara energy demand .....	34
<b>Fig. 3.3</b> Solar micro grid supply to Ha Lehloara energy demand .....	35
<b>Fig. 3.4</b> Wind micro grid supply to Ha Lehloara energy demand .....	38
<b>Fig 3.5</b> Hydro/generator micro grid .....	39
<b>Fig 3.6</b> Solar and generator hybrid micro grid .....	39
<b>Fig 3.7</b> Solar/wind hybrid micro grid .....	40
<b>Fig 3.8</b> Solar/Wind/diesel generator hybrid micro grid .....	40
<b>Fig 3.9</b> Solar/hydro hybrid micro grid .....	41
<b>Fig 3.10</b> Solar/hydro/energy storage/generator hybrid micro grid .....	41
<b>Fig 3.11</b> Solar/hydro/ hybrid micro grid .....	42
<b>Fig 3.12</b> Solar/Wind/diesel generator hybrid micro grid .....	42
<b>Fig 3.13</b> Hydro/Wind micro grid .....	43
<b>Fig 3.14</b> Hydro/Wind/Generator micro grid .....	43
<b>Fig 3.15</b> Solar/hydro/wind/energy storage hybrid micro grid .....	44
<b>Fig. 3.16</b> Solar/hydro/wind/generator hybrid micro grid.....	44
<b>Fig 4.1</b> ‘Double-hump’ daily energy demand profile .....	54
<b>Fig 4.2</b> Seasonal Profile .....	55
<b>Fig 4.3</b> Yearly Profile .....	55
<b>Fig 4.4</b> Malibamatšo river flow .....	55

<b>Fig 4.5</b> Micro hydropower system configuration .....	56
<b>Fig 4.6</b> Micro hydropower output from HOMER .....	57
<b>Fig 4.7</b> Micro hydropower Monthly electricity production .....	57
<b>Fig 4.8</b> Micro hydropower Monthly electricity consumption .....	58
<b>Fig 4.9</b> Total cost of hydropower micro grid system configuration .....	59
<b>Fig 4.10</b> System configuration for hydro/diesel generator .....	59
<b>Fig 4.11</b> Micro Hydro/diesel generator simulations .....	60
<b>Fig 4.12</b> Hydropower/Generator micro monthly electricity Production .....	60
<b>Fig 4.13</b> Hydropower/generator micro grid monthly electricity consumption .....	61
<b>Fig 4.14</b> Micro Hydro/diesel generator total cost .....	62
<b>Fig 4.17</b> Average monthly temperature of Ha Lehloara .....	64
<b>Fig 4.18</b> Jinko Eagle PERC60 300W PV search space .....	64
<b>Fig 4.19</b> Charge Controller search space .....	66
<b>Fig 4.20</b> Fronius Symo 20.0-3-M search space .....	67
<b>Fig 4.21</b> Search space of Hoppecke 24 OPzS 3000 .....	68
<b>Fig 4.22</b> Solar microgrid simulations .....	69
<b>Fig 4.23</b> Solar micro monthly electricity Production .....	69
<b>Fig 4.24</b> Solar electricity monthly Consumption .....	70
<b>Fig 4.25</b> Cost of Solar configuration .....	71
<b>Fig 4.26</b> Sensitivity analysis results.....	71
<b>Fig 4.27</b> Solar/Generator system configuration .....	72
<b>Fig 4.28</b> Solar/Generator system simulations .....	72
<b>Fig 4.29</b> Solar/Generator micro monthly electricity Production .....	72
<b>Fig 4.30</b> Solar/Generator monthly production and consumption .....	73
<b>Fig 4.31</b> Diesel Generator Emissions .....	74
<b>Fig 4.32</b> Solar/Generator system Cost .....	74
<b>Fig 4.33</b> Sensitivity analysis results graph .....	75
<b>Fig 4.34</b> Wind speed at Ha Lehloara .....	76
<b>Fig 4.35</b> Wind profile at Ha Lehloara .....	76
<b>Fig 4.36</b> Search space of wind turbine .....	77
<b>Fig 4.37</b> Wind/Generator system configuration .....	79
<b>Fig 4.38</b> Wind/Generator system simulations .....	79
<b>Fig 4.39</b> Wind/Generator electricity production .....	79
<b>Fig 4.40</b> Wind/Generator electricity consumption .....	80
<b>Fig 4.41</b> Diesel Generator fuel consumption .....	80
<b>Fig 4.42</b> Wind/Generator system cost .....	81
<b>Fig 4.43</b> Solar/Wind system configuration .....	82
<b>Fig 4.44</b> Solar/Wind system output .....	82
<b>Fig 4.45</b> Solar/Wind micro grid monthly electricity Production .....	82
<b>Fig 4.46</b> Solar/Wind electricity consumption .....	83
<b>Fig 4.47</b> Solar/Wind system Cost .....	84
<b>Fig 4.48</b> Solar/Wind/Generator microgrid system configuration .....	84
<b>Fig 4.49</b> Solar/Wind/Generator simulations .....	85
<b>Fig 4.50</b> Solar/Wind/Generator micro monthly electricity Production .....	85
<b>Fig 4.51</b> Solar/Wind/Generator electricity consumption .....	86
<b>Fig 4.52</b> Diesel Generator Emissions .....	86
<b>Fig 4.53</b> Solar/Wind/generator system Cost .....	87

<b>Fig 4.54</b> Sensitivity analysis results.....	88
<b>Fig 4.55</b> Solar/hydro hybrid micro grid system configuration .....	89
<b>Fig 4.56</b> Solar/hydro hybrid micro grid system simulations .....	89
<b>Fig 4.57</b> Solar/hydro hybrid micro grid electricity consumption .....	89
<b>Fig 4.58</b> Solar/Hydro electricity consumption.....	90
<b>Fig 4.59</b> Solar/Hydro system cost .....	91
<b>Fig 4.60</b> Solar/Hydro/Generator system configuration .....	91
<b>Fig 4.61</b> Solar/Hydro/generator system simulations .....	91
<b>Fig 4.62</b> Solar/hydro/generator electricity consumption .....	92
<b>Fig 4.63</b> Solar/Hydro/Generator electricity consumption .....	93
<b>Fig 4.64</b> Diesel Generator fuel consumption .....	93
<b>Fig 4.65</b> Solar/Hydro/Generator system cost.....	94
<b>Fig 4.66</b> Solar without battery/hydro hybrid micro grid system configuration .....	94
<b>Fig 4.67</b> Solar without battery/hydro hybrid micro grid system simulations .....	95
<b>Fig 4.68</b> Solar/hydro hybrid micro grid electricity consumption .....	95
<b>Fig 4.69</b> Solar without battery/Hydro electricity consumption .....	96
<b>Fig 4.70</b> Solar without battery/hydro micro grid system cost .....	96
<b>Fig 4.71</b> Solar/hydro/Wind configuration.....	97
<b>Fig 4.72</b> Solar/hydro/Wind configuration.....	98
<b>Fig 4.73</b> Solar/Hydro/Wind electricity production .....	98
<b>Fig 4.74</b> Solar/Hydro/Wind Consumption .....	99
<b>Fig 4.75</b> Solar/hydro/wind cost.....	99
<b>Fig 4.76</b> Solar/Hydro/Wind/Generator configuration .....	100
<b>Fig 4.77</b> Solar/Hydro/Wind/Generator optimisation results .....	100
<b>Fig 4.78</b> Solar/Hydro/Wind/ /generator micro grid system electricity production .....	100
<b>Fig 4.79</b> Solar/Hydro/Wind/generator electricity consumption .....	101
<b>Fig 4.80</b> Solar/Hydro/Wind/Generator system cost .....	102
<b>Fig 4.81</b> Comparison of Capital, Operating, Fuel costs and LCOE .....	104
<b>Fig 4.82</b> Battery cost comparison .....	105
<b>Fig 4.83</b> Technical values .....	106
<b>Fig 4.84</b> Economical values .....	107
<b>Fig 4.85</b> Sensitivity analysis results graph .....	109
<b>Fig 4.86</b> Hourly system performance .....	110

## **Abstract**

The study analysed different types of hybrid micro grids system configurations and found out the following to be both technically and economically viable: (a) PV with Levelised Cost of Electricity (LCOE) of R4.64/kWh, (b) PV/Wind of R5.03/kWh, (c) PV/Wind/Generator at R5.16 /kWh and lastly (d) PV/Generator of R4.80/kWh. These viable system configurations have more than 93.1 % renewables. All four technically and economically viable system configurations were found to be more sensitive to either price of diesel or inflation rate. As diesel price increased from R13.00/litre to R15.00/litre, LCOE increased from R5.15/kWh to R5.24/kWh. As inflation rate changed from 5.00 % to 6.50%, LCOE decreased from R4.64/kWh to R4.42/kWh. The most suitable system configuration has been found to both technically and economically viable is solar/generator with LCOE of R4.80/kWh and lower carbon emissions of 4843 kg/yr greenhouse gas emissions. For this solar/generator, NPV is R940 994.00, IRR is 18%, while ROI is 15.5% and payback period is 5.81 years.

Any hybrid micro grid system that had hydro component in its system configuration was found to be not viable due to the high capital cost which contributed to high LCOE. The high cost of the system configuration that included the hydro component had been brought about by the high cost of civil works for erecting diversion weir for the micro grid power station.

## **Chapter 1: Introduction**

### **1.1 Background**

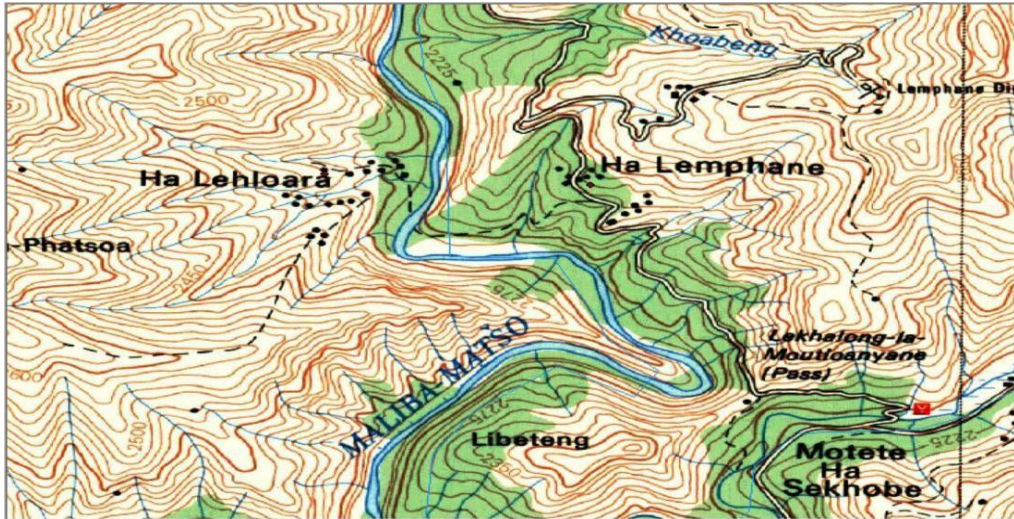
Energy as a source of life on Earth is very important for both economic, social and environment needs of daily lives and as means to poverty reduction and improvement of living standard for households[1] [2]. According to World Bank study only 17.14% of the world's population (about 1.2 billion people) do not have access to electricity [3] and there are more than 600 million inhabitants in Africa without access to electricity [4]. The rural villages in Africa have a very low electrification rate of 14% [4] which makes it very difficult for both economic growth and human development. In 2014, 63% of Population in the Sub Saharan Africa (SSA) did not have access to electricity [5]. The global demand for energy in 2017 was met by electricity which was generated from fossil fuels such as coal, natural gas and oil and of this energy demand, only 23% was from renewal resources [3]. Electricity generated from fossil fuels has adverse environmental and health effects due to green gas emissions. Furthermore, due to gradual depletion of fossil fuels and threat of climate change and hazardous impact to ecosystem, there is urgent need to turn to renewable resources for energy generation [6] [7].

There are some renewable energy initiatives in Lesotho. Firstly, Lesotho as the SSA country has some initiatives for energy generations in the rural areas between Public Private Partnership and other international development partners. According to UNDP/GEF (2019), first initiative is carried out by One Power Company as Independent Power Producers (IPP) for Solar power Projects at Ha Ramarothole in Mafeteng district with projected Renewable Energy (RE) capacity of 20 MW financed by Scatec Solar and Norfund and USD \$600k (M8.6 million) grant from United States of America (USA). The second component of this solar Project at Ha Ramarothole is done by a Chinese company as IPP whose financier is Exim Bank of Government of China. This Chinese company will construct solar farms of total projected RE capacity of 70 MW in two phases. The first phase will be of a construction of 30 MW solar farm which will be done in the first eighteen months and another 40 MW for the remaining period. The other solar farm of capacity 70 MW will be constructed by One Power company at Ha Makebe. This project is financed by Renewable Energy Performance Platform from United States of America. Secondly, there are some proposals to be financed by UNDF GEF for the construction of mini-grids in the following districts: Mohale's Hoek, Mokhotlong, Qacha's nek, Quthing and Thaba-Tseka. For this UNDP GEF project, mini-grids and energy centres in Mohale's Hoek for the following villages: Ribaneng, Ketane, Phamong, Koebunyane

and Mpharane of total annual demand of 117 640 kWh would need an investment of M17 million for construction of these mini-grids and energy centres. However, the Project IRR would be -15% to -11% while the required tariff would be between M6.90/kWh to M8.49/kWh. This project is expected to start in 2020 as soon as the contracts with IPPs have been signed. The utility tariff of M6.90/kWh or M8.90/kWh compared to the current Lesotho Electricity Company tariff of M 1.4782/ kWh (LEWA, 2019) as at May 2019 is too high for households in the rural areas. The IRR of -15% or -11% simply means this project is not viable for the IPP who is interested to make profit. This project is expected to take off later in this year and villages will benefit from these mini-grids and energy centres across these mentioned districts upon completion. The contract between UNDP GEF and IPP is in such a way that IPP is expected to raise funds for the project while UNDP GEF will finance the gap between the total capital and what IPP has raised based on performance of IPP. This means an IPP is expected to start the project using its own costs; funding by UNDP GEF will come at the later stage based on performance of an IPP. This project was expected to take three years from 2018, but is behind schedule due to delay in the awarding of contracts to IPPs who won tender bids for development of these mini-grids and energy centres. Lastly, National University of Lesotho (NUL) Energy Research Centre won M10.3 million to supply two rural villages in Lesotho with Solar electricity (NUL Research and Innovations, 2020).

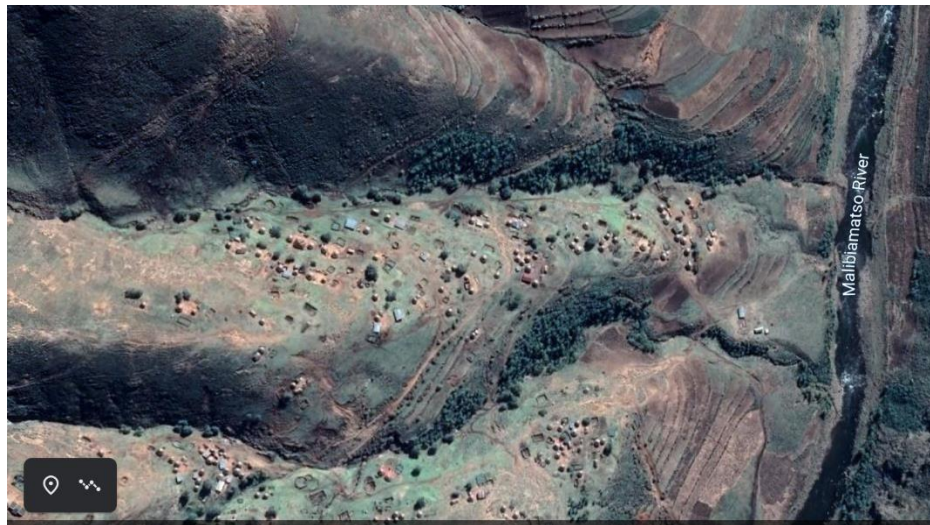
Against this background, this research project strives to model and optimise micro grids for rural villages in Lesotho using renewable energy sources (RES) such as wind, solar radiation and hydro. High capital costs of grid connectivity and high levels of unemployment in rural villages in Lesotho [5] justifies that there is a need for construction of micro grids using renewable energy sources such as wind, solar radiation and hydro. Due to their **intermittency**, **variability** and **availability** in quantity, renewable energy resources are normally pooled with other sources to generate a hybrid renewable energy grid [9].

The study area is Ha Lehloara village of one hundred (100) households in the district of BothaBothe in Lesotho. Ha Lehloara Village lies within the following coordinates - 28° 56′ S and 28° 33′ E (-28.949041,28.556528) as shown in **Fig. 1.1** [10],the village is along Malibamatšo river. The purpose of the study is to model and optimise micro grid on renewal energy sources such as wind, solar radiation and hydro for Ha Lehloara village.



*Fig 1.1 Ha Lehloara village*

Ha Lehloara , illustrated in **Fig 1.2** [10] below is a village of one hundred households situated in the district of Botha-Bothe. Malibamatšo river is 0.12 kilometres from the village which makes it suitable for hydro power plant as one of the components of hybrid micro grid.



*Fig 1.2 Malibamatšo river at Ha Lehloara village*

Water flow from Malibamatšo river is continuous throughout the year. The elevation of this village which is in mountainous region of Botha-Bothe is around 2230 metres above sea level. At Ha Lehloara, average wind speed is 5.12 m/s, average solar irradiance is 5.01 kWh/m<sup>2</sup>/day with average clearness index of 0.485 while Malibamatšo river flow is 14.34 m<sup>3</sup>/s. The average monthly temperature is 9.87 °C with low temperatures dropping significantly from April and beginning to rise from August.

## 1.2 Problem statement

Lesotho is facing a number of challenges when it comes to electricity access. Firstly, Lesotho which is in Sub-Saharan Africa (SSA) had 30.2% households connected to electricity grid in 2013 and the electrification rate target of Lesotho government was 35% in 2015 [11]. This means about 69.8% of households did not have access to electricity in 2013. Lesotho had 72% of the urban households connected to the grid while only 5.5% of rural households were grid connected in 2015 [5]. Secondly, Lesotho has a serious shortage of electricity generation as shown by the following facts. Lesotho produced 72 MW capacity from Muela Hydro power which was only able to meet 500 GWh of energy consumption in 2013 while the national energy demands reached over 800 GWh in which 300 GWh was imported from South Africa and Mozambique [12]. The situation improved slightly from 2013 as Lesotho had an installed electricity of 74.7 MW while the electricity peak demand was 177.31 MW [13] in 2018. This country's short fall is met through electricity imports from ESKOM, which is national utility in South Africa and EDM, which is a national utility in Mozambique.

Despite the attempts of Lesotho government to connect households especially in the rural areas to the grid, there are still some impediments. Firstly, Lesotho Electricity Company and Water Authority (LEWA) have Universal Access Fund (UFA) as means of subsidizing capital costs at 10% for rural electrification through grid expansion which LEC as a utility company charges this levy [14]. Since Lesotho relies on government subvention and Universal Access Fund (UAF) which contributes barely 10% of the capital costs there is a high need for capital investment in the generation of electricity in order to improve economic and social needs of the country and its citizens especially in the rural regions of the country.

About 60% of population who live in rural areas in Lesotho do not have access to electricity [5]. Despite initiatives by Government of Lesotho to address problems of energy for the rural communities through initiatives for energy generations in the rural areas between Public Private Partnership and other international development partners, there is still a problem of establishing model which is economically and technically viable for these rural communities. Hence there is a need to model and optimise micro grids for rural areas in Lesotho which will be affordable in terms of cost of energy for the communities. Furthermore, due to its mountainous and rugged hilly regions, scattered remote rural villages, construction of generation energy stations, transmission and distribution of power is very costly [15].

Households in Ha Lehloara do not have access to electricity. They use biomass such as shrubs, wood, cow dung for cooking and heating, paraffin for lighting, candle lamp for lighting and solar panels for charging cell phones. Burning of unclean biomass usually result in environmental pollution which may cause respiratory diseases and emissions of greenhouse gasses and carbon dioxide which are very hazardous to human health [16]. Women and girls still travel about five kilometres to fetch wood for cooking and heating, and this retard human development of girls in terms of their education studies and their safety against unplanned marriages. The study will strive to find the best and least cost hybrid system for energy supply for Ha Lehloara village given the intermittency and variability of the renewable energy resources that will be used to model and optimise this system. The whole purpose of this study is to characterise the renewable energy resources such that an assessment of these energy resources is done in order to find the least cost-effective hybrid combinations of these energy resources in order to produce energy required for the village. Due to intermittency and variability of these energy resources, sometimes one resource is more than others in the energy generation process. Due to variability of these energy resources, sometimes there is more resource than the other for energy generation. Therefore, hybrid system will compensate for the short fall of energy supply because of other resources. The study strives to find the most economic mix of these energy resources (wind, solar, hydro).

### **1.3 Justification of the study**

Due to its terrain, most communities in the rural areas of Lesotho do not have access to electricity. Despite efforts by government of Lesotho through electrification unit to connect villages to the main grid, more than 80% of the villages in the rural areas are still not connected to the grid. Hence there is need to supply energy to these rural areas through micro grids so that they can access energy. The other challenge is that the high costs of electricity from the grid acts as a barrier to most households to access this electricity. Therefore, it is important to model and optimise a micro grid which will act as a basis for energy supply in the rural areas of Lesotho. Lesotho has adequate natural locally available energy resources for energy generation. For example Lesotho has daily solar radiation from 5 kWh/m<sup>2</sup> to 7 kWh/m<sup>2</sup> and daily hours for sunshine range between 10.2 and 13.8 [17] and has reliable stream water flow from rivers such as Malibamatšo and these locally available resources [18] could be used to develop the micro grid hybrid system. Abundance of local energy resources will enable model and optimising of micro grid that consists of solar, wind , hydro and diesel generator as a

backup [19]. Lastly very high annual costs of rural electrification through grid connection by Lesotho government will not be incurred if micro grids are constricted for energy provision in the rural villages rather capital cost sharing by government, investors and other interested parties will be used to construct micro grids in the rural villages of Lesotho. Micro grids based on renewable energy sources are a best option for rural villages in Lesotho because of the less installation, maintenance and operation costs compared to electricity from the main grid connection [15].

Due to intermittency and variability of renewable energy resources, it may not be wise to depend on one energy resource to generate power in order to supply this rural village. Sometimes producing energy from solar only might not produce energy power because of rainy weather condition and the cost of storing power into battery bank may be too expensive. Similarly producing energy from wind only also be too expensive because sometimes there is no wind to generate power. Similarly, depending on water only may not be a best option because sometimes there is not enough water to generate electricity because of dry seasons. Therefore, in order to address this problem, resource assessment of these renewable energy resources is very important in order to determine their potential for power generation in order to reduce power generation costs and then identify the most economic hybrid system that can be developed for this rural village.

#### **1.4 Research objectives**

The research aims to address the following objectives in the context of micro grids in rural areas of Lesotho:

- To design solar, hydro, wind and hybrid micro grids with high renewable fraction and low cost of energy for rural household in Lesotho
- To optimise solar, hydro, wind and hybrid micro grids for rural household in Lesotho

#### **1.5 Research Questions**

The research project aims to address the following research questions in the context of micro grids in rural areas of Lesotho:

- What are the optimal costs of technical components of micro grids in the rural areas of Lesotho?
- What is the extent of economic viability of micro grids in the rural areas of Lesotho?
- What is the Levelized Cost of Energy (LCOE) of electricity from micro grids in the rural areas of Lesotho?

## **1.6 Research scope**

Research is on modelling and optimisation of hybrid micro grid using solar, wind and hydro as renewable sources for Ha Lehloara which is a rural village in Botha-Bothe using Hybrid Optimization Model for Electric Renewables (HOMER). Research is going to be based on study area which is Ha Lehloara Village in the district of Botha-Bothe in Lesotho. Ha Lehloara Village lies within the following coordinates are  $28^{\circ} 56' S$  and  $28^{\circ} 33' E$ . Ha Lehloara village is along Malibamatšo river. This research will further optimise the components by identifying the most affordable components of this hybrid system and calculating the Lowest Cost of Electricity (LCOE) and Net Present Value (NPC) of this system.

## **1.7 Dissertation outline**

This dissertation is divided into five chapters. Chapter 1 is the introduction, which outlines the problem statement and justification. This is followed by Literature Review in chapter 2, which gives the background information. Chapter 3 is the Methodology whilst Chapter 4 focuses on the Results and their interpretation / discussions. Conclusions and recommendations for further work are detailed in Chapter 5.

## **Chapter 2: Literature Review**

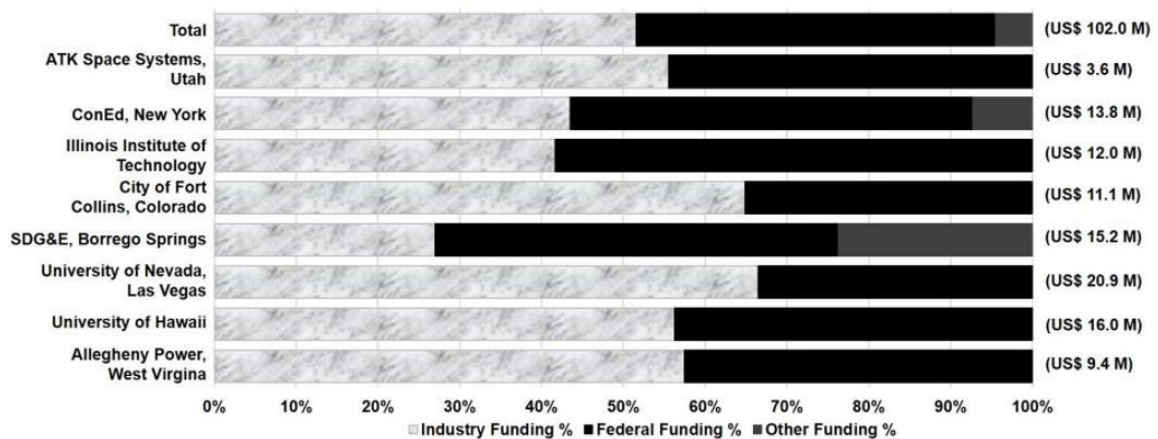
Sub-Saharan Africa is one of the regions with the lowest access to electricity of 32% despite its vast availability of natural resources such as wind, solar, waves and crops [20]. Many communities in Southern Africa lack energy access due to the following factors: dispersed and scattered communities, low usage of energy due to lack of income, very high costs for distribution of power and lack of financial and human capital. Africa has 95% of the world's best winter sunshine area with reception of  $6.5 \text{ kWh/m}^2$ . Africa has potential of utilising 95% of Photovoltaic (PV) solar thermal and solar electrical power [21]. Lesotho has mean annual daily solar radiation potential of  $5.4 \text{ kWh/m}^2$  while wind potential varies from average wind speed of  $3.5\text{m/s}$  to  $25\text{m/s}$  [22]. Sub Saharan Africa 's total primary energy, excluding South Africa, is 82.1% of biomass which is made of biofuels and waste [23]. Due to low rural electrification of 11% in Sub-Saharan Africa, biomass sources such as cow dung, charcoal, fuelwood and crop residues are used for energy production [24]. There are currently no bioenergy or biomass power generation initiatives in Lesotho [25].

Micro grid is a group of interconnected loads and distributed energy resources [26] such as renewable energy resources [27], generators, storage systems and loads within defined electrical boundaries which gives rise to a self-sufficient energy system [28] and it can either be connected or disconnected from grid and as such can operate both as *grid-connected* or *island mode*. Island or isolated micro grids may guarantee the reliability of energy supply in small remote areas where expansion of grid may both be technically and economically not feasible [28]. The following factors are normally considered in the designing of micro grids: critical load, equipment ,storage capacity and energy supply availability [29]. Micro grids seem to be a cost-effective solution to accelerate energy access for households that are found far away from existing grid infrastructure [30]. The main advantage of constructing micro grids is their reliability and security of energy supply for the communities [31]. Micro grids must have enough energy capacity to supply load and excessive capacity must be reduced in order to avoid high running costs [27]. An optimal design of micro grid must take into consideration energy sufficiency and cost. There are various designs of micro grid modelling and optimisations techniques. For example, optimal sizing may incorporate wind turbine, solar modules, hydro battery and inverter [27]. The micro grid system is going to be based on hybrid system due to intermittence of solar radiation and water variations of stream flow and variation of wind speed [18].

Micro grid viability lies in the hybridization of the renewable resources in order to address issue on intermittency, reliability and security of supply. This project deals with micro grid in island mode supplied by renewable energy resources namely: wind, solar radiation, hydro and battery as backup power supply. There should be sufficient capacity taking into account intermittency of some energy resources within a micro grid in order to safely supply loads, while excessive capacity must be avoided in order to minimize overall cost of a station for both technical and economic efficiency of the components of the system. Optimal design of the capacity of DERs within islanded micro grid should consider trade-off between energy sufficiency and cost of a station [27]. The goal is to strive to optimise islanded micro grid that is supplied by hydro, wind, solar radiation and battery system by considering both its technical and economic efficiency. The main objective is to reduce the plant cost by ensuring energy efficiency, taking into account renewable generation and load [27]. Each of these renewable energy sources used in micro grid are going to be examined below in order to study their contribution and impact in a micro grid. Micro grids in the rural villages have been found to be a better option than grid connection of its high cost. For example , rural electrification in the

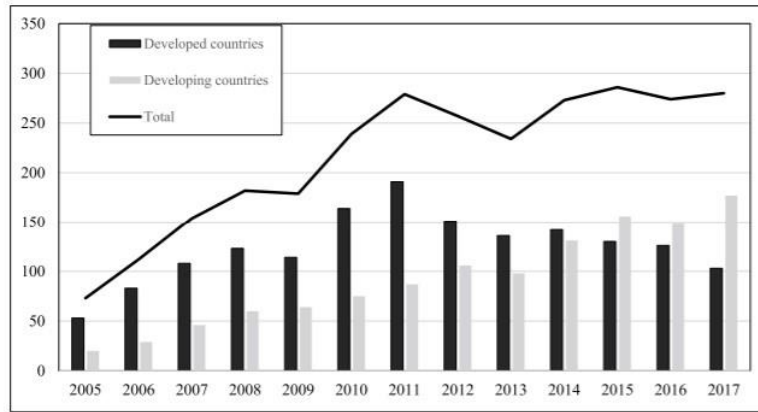
rural villages of India cost US\$8000US/km to US\$10000/km due to rough terrain in these rural villages and it was deduced that rural electrification by grid connection is not a viable option [2].

Capital investment for micro grid is still high because of expensive components like photovoltaic (PV) modules, battery storage, inverters [31]. This means some financial assistance from third parties such as government or private investors is required to construct micro grid plant such as the case with Ha Marothole mini-grid station. The most common micro grid financing models in the United States of America (USA) are Power Purchase Agreement and Energy Performance Contract [31]. **Fig 2.1** [31] below shows a cost sharing model used in the USA for the funding of micro grids.



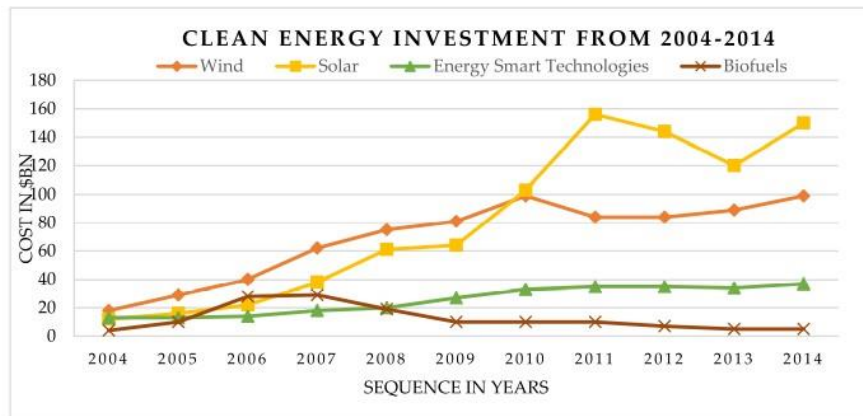
**Fig 2.1** Micro grid development cost sharing in USA

Nevertheless, both global investment and cost trends for renewable energy resources projects have been positive. There has been considerable growth and investment in renewable energy sector globally as shown in **Fig 2.2** [32] below, which gives an annual investment costs in renewable energy resources for both developing and developed countries and indicate the growth trends from 2005 to 2017.



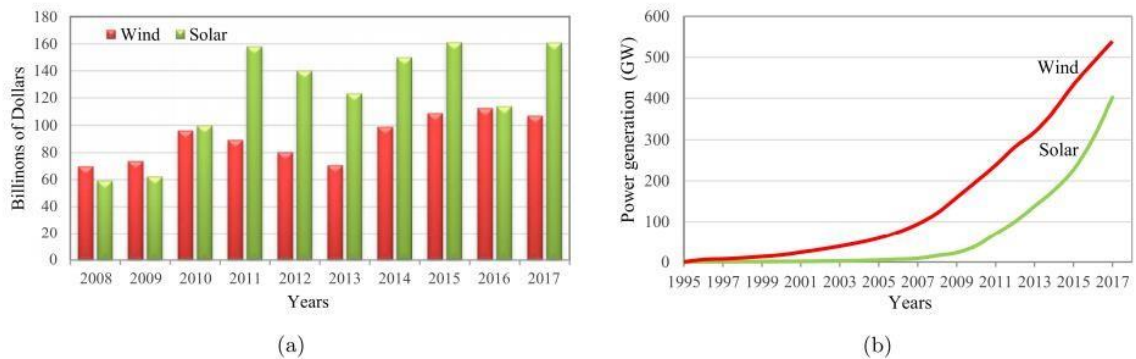
**Fig 2.2** Global investment in renewable power from 2005 to 2017

**Fig 2.3** [33] below also shows remarkable global investment on renewable energy for specific renewable energy sources from 2004 to 2014 [33] as a way of addressing issues of global warming by reducing carbon emissions from generation of energy from fossil fuels.



**Fig 2.3** Clean energy investment from 2004 to 2014

The main race in terms of investment and installed capacity seems to be between wind and solar and can be seen in **Fig 2.4** [34] below.



**Fig 2.4** Wind and solar power: (a) global investment and (b) worldwide power generation

**Fig 2.4** (a) shows that from the 2008 to 2009, more investment was directed towards wind and it was only in 2010 when investment in solar started becoming greater than in wind. **Fig 2.4** (b) shows that wind had greater power generation than solar from 1995 until 2017.

The renewable energy sources of the proposed hybrid micro grid system and their characteristics are explained in the sub-sections below.

## 2.1 Water

Water is a renewable source of generating clean hydro power which is environmentally friendly and contributes about 18.5% of the global electricity generation [35] and makes global capacity of 100 GW which was 76% of all renewable sources in 2013[36] [37]. Hydro power stations are classified according to the generation capacity as shown in **Table 2.1** [37] [38] below and water head.

**Table 2.1** Classification of hydro power Stations

Hydro Power	Installed Capacity
Pico	< 5 kW
Micro	5 kW – 100 kW
Mini	100 kW – 1 MW
Small	1 MW – 25 MW
Medium	25 MW – 100 MW
Large	>100 MW

Similarly, a hydro power is also classified according to water head. Hydro power station with water head below 3 m is called ultra-low-head, with less than 40 m is called low head hydro plant while above 40 m is medium or high head [38]. Since Lesotho has a lot of running water, it has a great potential for both large and small hydro power stations for its domestic needs [39]. Small hydro power station of less than 10 Mw can either be standalone or hybrid systems with other sources or renewable energy [40] in rural areas.

### 2.1.1 Generation of hydro power

Large hydro power stations are generally classified as capital intensive investments because of the high generation costs. On the other hand, small hydro power stations do not take advantage

of scale of economies because of lack of large dams or reservoirs [35]. Hydro power generation depends on several components such as choice of turbine, water head, flow rate and efficiency of the turbine [41]. Flow rate depends on amount and rate of rainfall and mostly importantly climate change which will increase hydro power generation in some parts of the world and decrease hydro power generation in others [42] [43]. As a way forward sustainable renewable energy technologies for hydro power generation are the best way to mitigate climate change [35]. The first step is to assess the water resource when designing a hydro power station. The main parameters that are measured from the water resource are the water head and flow rate which will determine the amount of power that can be obtained from such water resource. Secondly, both efficiency of a turbine and generators play an important role in calculating the amount of hydro power. The choice of a turbine depends on the net head and flow rate. The following parameters are very important when choosing a turbine: type, size and efficiency in order to produce required hydro power [44].

Therefore, the formula [44] for calculating hydro power is:

$$P = \eta \rho g Q_d H_n \quad (\text{W}) \quad (1)$$

or

$$P = \eta \rho g Q_d H_n \quad (\text{kW}) \quad (2)$$

where:

$\eta$  - Efficiency of turbines and generators

$\rho$  - density of water (1000 kg/m<sup>3</sup>)

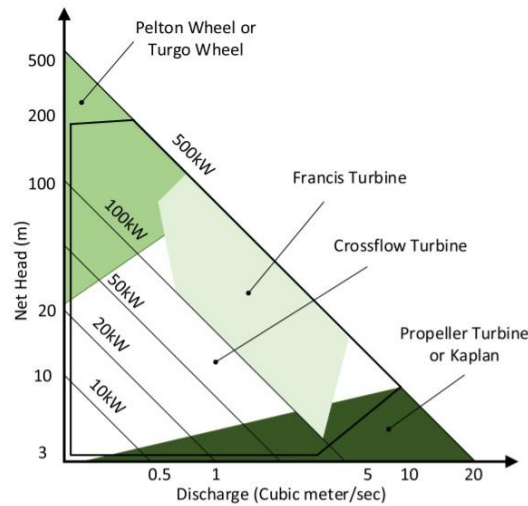
$g$  - acceleration due to gravity (9.81 m/s<sup>2</sup>)

$Q_d$  - design discharge / flow rate (m<sup>3</sup> /s)

$H_n$  - net head (m)

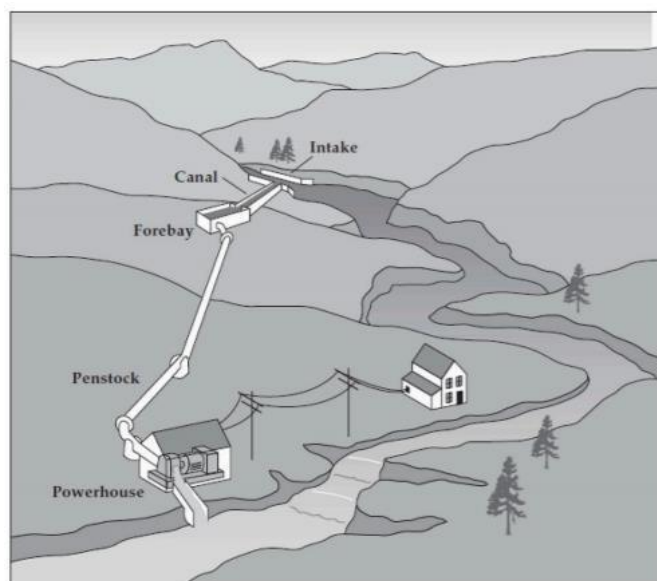
$H_n$  is Gross Head less losses incurred when transferring water into and away from turbine. Gross Head is maximum vertical fall of water from upstream level to downstream level.

Selection of turbine depend on several parameters namely: power to be produced, net head and flow rate of the stream. **Fig 2.5** [45] below shows different turbine types and their output power.



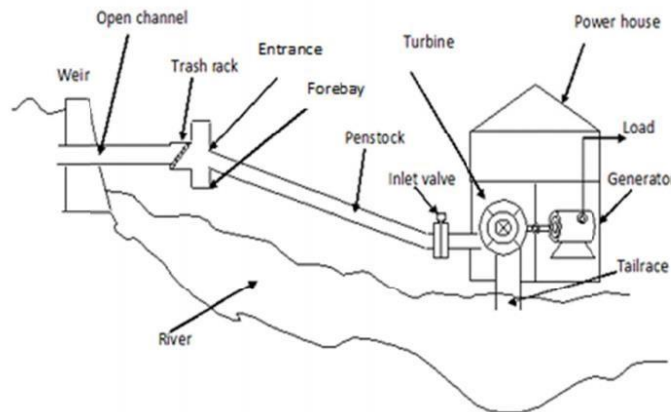
**Fig 2.5** Turbine selection graph as a function of net head, discharge and power

Layout required for generation of hydro power depends on size of the hydro power station to be built. Small hydro power projects (SHPP) are usually considered to more eco-friendly compared to large hydro power projects because of less displacement of the population of the area and minimum harmful effects on flora and fauna in SHPP [46] [47] Large hydro power projects normally require high costs for construction of dams for the reservoir for creating head, which is essential when the water is released from the reservoir through the penstock to the generation station. On the other hand, in small hydro power projects, the hydropower system uses running water to produce mechanical energy, which is later converted to electrical energy by using turbine and generators. SHP does not require the reservoir. In SHP, the plant is established on a run-of-the river by just diverting water from river to create the head for water that passes through penstock. **Fig 2.6** [45] below shows the layout of SHPP.



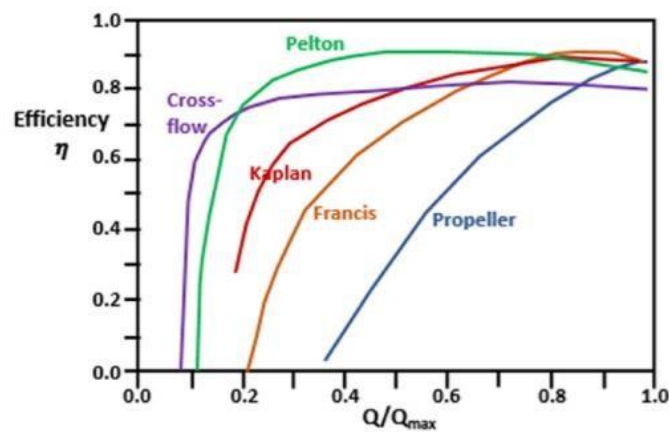
**Fig 2.6** Layout of SHPP

The weir may need to be constructed to divert water from the main river in order to construct a micro hydro power station. A weir is a barrier across the river that is designed to change the flow of the water. Weir is a little wall or a minor dam with a notch to channel the flow of water to the power station for generation.[48]. In a weir, the water overflows the weir, but in a dam the water overflows through a special place called a spillway [49] . **Fig. 2.7** [44] below shows a flow of water from weir along the penstock to the generating power house.



*Fig 2.7 Micro hydro power station generating from weir*

Efficiency curves of different turbines based on discharge ( $Q$ ) are shown in **Fig 2.8** [50] below.



*Fig 2.8 Turbines Efficiency Curves*

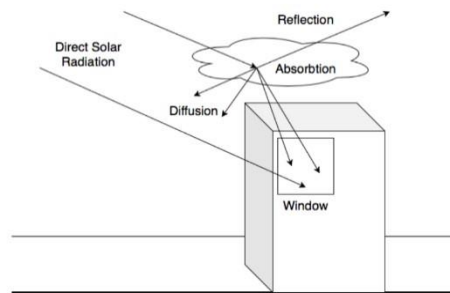
## 2.2 Solar radiation

### 2.2.1 Irradiance

The sun, as the primary source of energy on Earth, gives out solar energy which can be used to generate electricity. The sun provides clean source of renewable energy which can be used both for household and commercial purposes. The sun produces solar radiation spectrum which consists of the following rays at given wavelengths: ultraviolet rays (0 - 0.38  $\mu\text{m}$ ), visible light

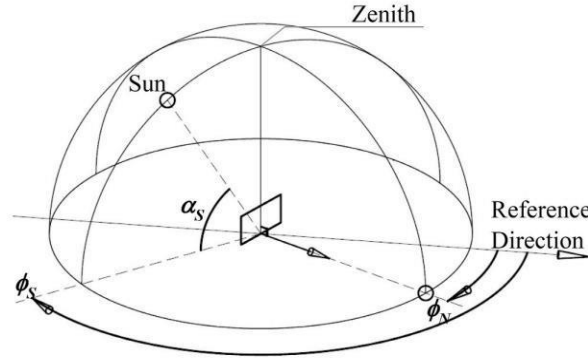
(0.38 - 0.78  $\mu\text{m}$ ) and infrared rays (0.78 -  $\infty$   $\mu\text{m}$ ). By the Stephan-Boltzmann law the Sun emissive power density denoted by ( $H_{\text{sun}}$ ) is given by  $H_{\text{sun}} = 6.3 \times 10^7 \text{ W/m}^2$  and entire surface of the sun, of diameter  $1.39 \times 10^9 \text{ m}$ , has emissive power is  $\phi_{\text{sun}} = 4\pi R^2 = 3.83 \times 10^{26} \text{ Watts}$ . The Sun emits solar radiation in all directions, however only a small portion of solar energy is intercepted by the Earth. Comparing with the world's annual energy consumption of 1.66 x 10<sup>14</sup> kWh in 2018 [51], the Earth's energy consumption is 3.83 x 10<sup>23</sup> kWh from the Sun in just one hour than that required to sustain the world energy consumption for a whole year.

Solar radiation can reach the Earth as beam or direct radiation and diffuse radiation. Beam/direct radiation is radiation that is received by the Earth without any scattering by the atmosphere while diffuse radiation is solar radiation that is received by the sun after its direction has been changed or scattered through the atmosphere. **Fig 2.9** [52] below shows both beam/direct radiation and diffuse radiation.



**Fig 2.9** Beam/direct and diffuse radiations

The amount of solar radiation either as beam/direct or diffuse that reaches the Earth's surface is dependent of the position of the sun. The rate of solar radiation which is received by an object on the earth per unit area is called solar irradiance measured in  $\text{W/m}^2$ . Amount of solar radiation that is received at a place in given time usually day or hour is called solar irradiance and is measured  $\text{kWh /m}^2/\text{day}$ . Irradiance can be measured by instruments called pyranometers and pyrheliometers. Position of the sun is very important for calculating an amount of radiation on a tilted PV surface. The two angles that are used to determine the sun's position are solar altitude angle ( $\alpha_s$ ), the solar zenith angle ( $\theta_z$ ) and the solar azimuth angle ( $\gamma_s$ ) shown in **Fig 2.10** [53] below. Solar altitude angle, ( $\alpha_s$ ), is the angle between solar beam and horizontal plane. Solar azimuth angle ( $\gamma_s$ ) is an angle that describes the compass direction of the sun.



**Fig 2.10** Angles for determining sun's position

The relationship between angle on incidence on a surface,  $\theta$ , and other angles are given by the following equations [54]:

$$\cos\theta = \sin\delta\sin\varphi\cos\beta + \sin\delta\cos\varphi\sin\beta\cos\gamma + \cos\delta\cos\varphi\cos\beta\cos\omega - \cos\delta\sin\varphi\sin\beta\cos\gamma\cos\omega + \cos\delta\sin\beta\sin\gamma\sin\omega \quad (3)$$

$$\cos\theta = \cos\theta_z\cos\beta + \sin\theta_z\sin\beta\cos(\gamma_s - \gamma) \quad (4)$$

where:

$\alpha_s$ : solar altitude angle

$\theta_z$  :the solar zenith angle

$\gamma_s$ : solar azimuth angle

$\varphi$ : **Latitude**, is the angular position north or south of the equator, north positive;  $-90^\circ \leq \varphi \leq 90^\circ$ [54].

$\delta$ : **Declination**, is the angular position of the sun at solar noon with respect to the equatorial plane i.e. the angle between the line joining the centres of the earth and sun to the equatorial plane; north positive;  $-23.45^\circ \leq \delta \leq 23.45^\circ$  [54]  $\beta$  : **Slope**, is the angle between the plane of the surface in question and the horizontal;  $0 \leq \beta \leq 180^\circ$ [54].

$\gamma$ : **Surface azimuth angle**, is the deviation of the projection on a horizontal plane of the normal to the surface from the local meridian, with zero due North, east positive and west negative;  $-180^\circ \leq \gamma \leq 180^\circ$ [54].

$\omega$ : **Hour angle**, is the angular displacement of the sun east or west of the local meridian due to rotation of the earth on its axis at  $15^\circ$  per hour.  $\omega$  is zero at solar

noon; when the sun is above the local meridian,  $\omega = 15(t - 12)$ ; morning is negative, afternoon is positive [54].

$\square$ : **Angle of incidence**, is the angle between beam radiation on a surface and the normal to the surface[54].

The formula [54] for calculating Number of day light hours( $N_d$ ) is given by:

$$N_d = \frac{2}{15} \omega_s = \frac{2}{15} \cos^{-1}(-\tan\phi \tan\delta) \quad (5)$$

Where:

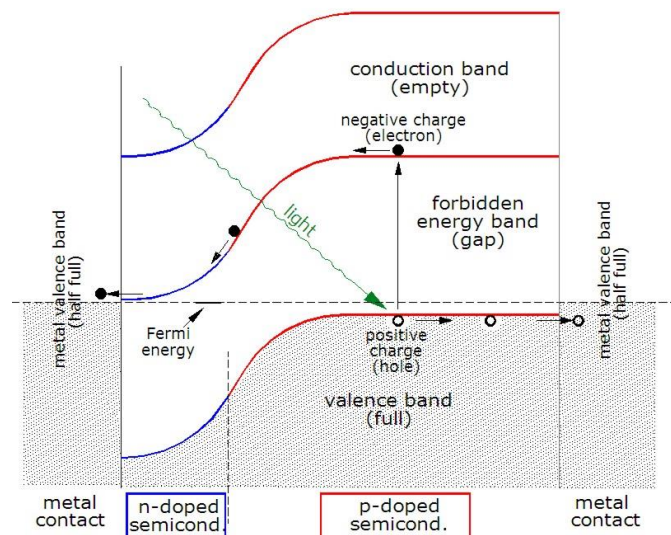
$\omega_s$ : is the sunset hour angle [54].

Solar irradiance received on the ground is influenced by clearness of the sky. The measure of clearness of sky is called Clearness index (K) which is calculated from data from pyranometer and data from clear sky. Clearness index varies from 0 and 1, where value 1 signifies the maximum amount of solar irradiance that will be received on the ground and 0 means total cloud cover and no irradiance to be received on the ground [55]. Clearness index is calculated as ratio of daily global horizontal terrestrial radiation(G) to daily extra-terrestrial radiation ( $G_{ex}$ ) reaching the Earth's surface on a horizontal plane. Hence ( $kt = G/G_{ex}$ ) [54] [56]. Since clearness index is a ratio of daily global radiation (G) horizontal terrestrial radiation to extra-terrestrial solar radiation reaching the earth's surface, the higher the clearness index, the clearer the atmosphere [57]. The higher the clearness index the higher the PV power that can be produced from solar radiation.

### 2.2.2 Solar cell

Since solar energy from solar irradiance can be used for heating and lighting, it must be captured/harnessed through special devices called solar cells. A solar cell also known as photovoltaic (PV) cell is a special cell that converts light energy which is stream of photos into electrical energy through a process called photovoltaic effect. During photovoltaic effect process, voltage is generated across p-n junction of a semiconductor material such as silicon. Solar cell (crystalline Silicon) is made up of n-type semiconductor (emitter) layer and p-type semiconductor layer (base). The two layers are sandwiched and hence there is formation of pn junction. Upon receiving incident light energy (absorbed light), in p-type region, electrons can gain energy and move into the n-type region. Thus, this flow of electrons resulting from ptype region to n-type region results in the generation of electricity. In a photovoltaic device, which is a device based on photovoltaic effect, due to doping, excited electrons are pulled away before

they can relax, and fed into an external circuit. The concept of photon plays an important role in understanding how electricity is generated by solar cell. A photon is a particle that represents a quantum of electromagnetic energy such as light or radio waves. Average Photon energy influences PV performance [58]. The minimum photon energy required for creating an electron-hole pair is the band gap energy of semiconductor material as shown in **Fig. 2.11** [59] below.



**Fig 2.11** Photo-generation of Charge Carriers during Photovoltaic effect

PV cell consists of semiconductor material such as silicon which is capable of converting light into electricity. As light is absorbed by semiconductor material, photons of light transfer their energy to electrons resulting in flow of such electrons and thus generate electricity. The photovoltaic effect which is applied in PV cell for generating electricity, depends on both irradiance and temperature. As irradiance increases, so do the current and power produced by PV cell. Secondly as temperature of the PV cell increases, the output voltage decreases significantly, the current increases only slightly, so overall the output power decreases. PV solar cells can be classified as Monocrystalline silicon(mon-Si) cells with highest efficiency of from 15% to 18%, or Polycrystalline/Multi-crystalline silicon(Poly-si) cells with efficiency from 13% to 15% or Amorphous / Thin Film cells with efficiency from 5% to 8%. A group of PV cells connected either in series or parallel form a PV Module shown in **Fig 2.12** [60] below. Lifespan of PV module on its annual performance degradation. For example, annual performance degradation of Monocrystalline silicon module is 0.8% while that of polycrystalline silicon module is 1% [61].



*Fig 2.12 PV Module*

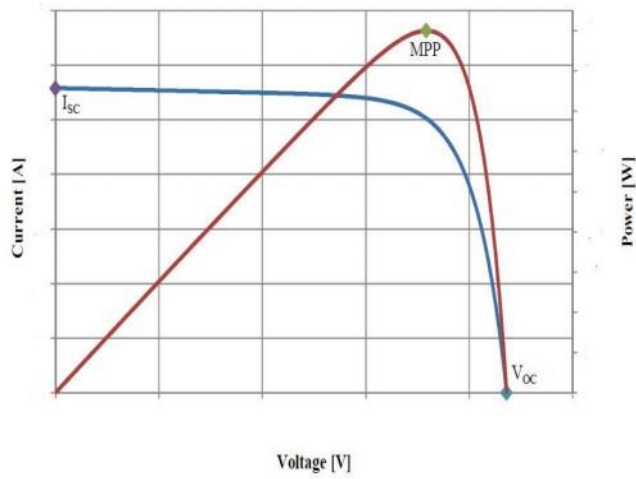
PV panels connected together either in series or parallel form a PV Array. **Fig 2.13** [62] below shows PV Array which consists of two strings of two solar panels each, where string means that these panels are connected in series.



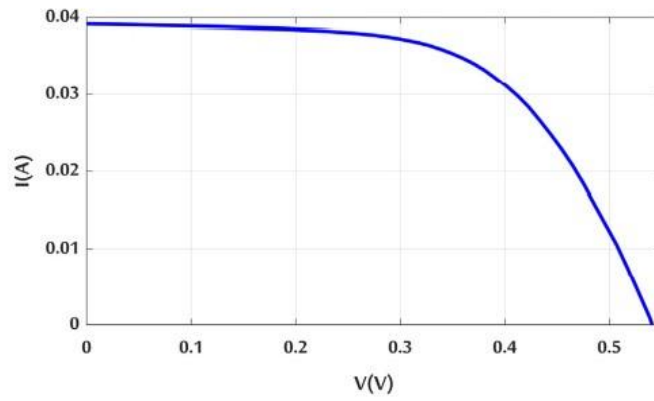
*Fig 2.13 PV Array*

### **2.2.3 Solar cell (PV) electrical characteristics**

The following parameters and curves are used to characterise behaviour of PV cell: Open circuit voltage ( $V_{oc}$ ), Short circuit current ( $I_{sc}$ ), Maximum power operating current ( $I_{mp}$ ), Fill factor (FF), Power conversion efficiency, I-V and P-V characteristics of a typical panel in **Fig 2.14** [63] [64] below. Short circuit current ( $I_{sc}$ ) of a PV cell is the maximum current that a cell can give out without damaging its own limit while open circuit voltage ( $V_{oc}$ ), is the maximum voltage that is produced by PV cell when there is a leak in the circuit. Maximum power operating current ( $I_{mp}$ ) is the maximum current produced by PV cell. I-V curve is shown in **Fig 2.15** [65] below measured at certain irradiance and temperature.

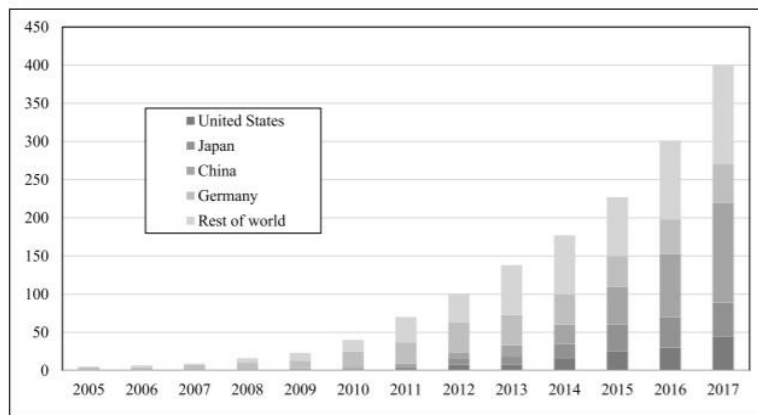


**Fig 2.14** PV I-V and P-V characteristics of a typical panel



**Fig 2.15** The PV solar cell I-V characteristic curve

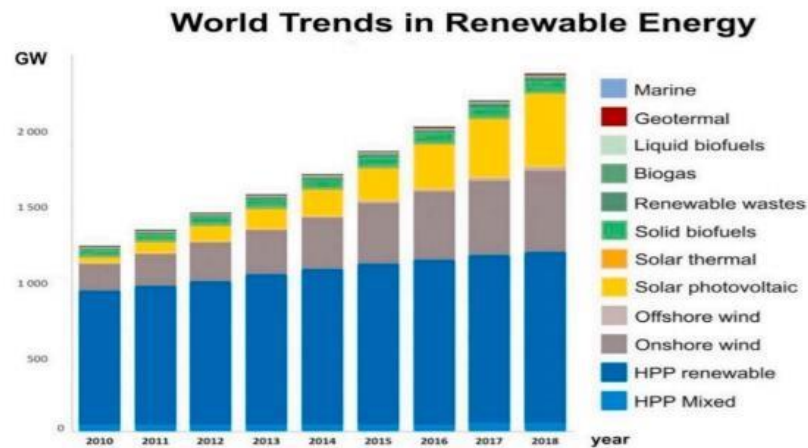
There was an increase in cumulative installed solar photovoltaics capacity (GWs) from 2005 to 2017 as shown in **Fig 2.16** [32] below.



**Fig 2.16** Global cumulative installed solar photovoltaics capacity

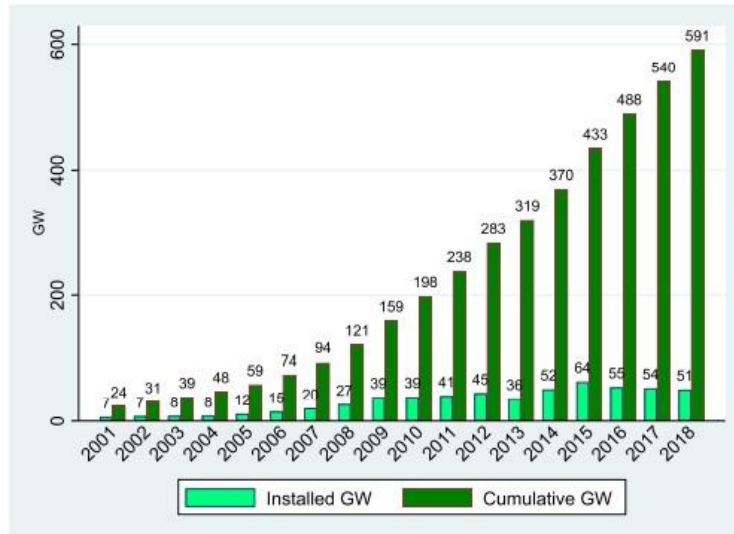
## 2.3 Wind

Wind is an intermittent renewable resource for producing electricity just like solar radiation. Wind energy is the fastest growing green energy technology globally [66]. Research has found out that battery energy storage systems (BESS) can mitigate intermittency of wind energy and this technology was used in Japan and United Kingdom despite its effectiveness not yet clear in the wind energy resource assessment [67]. Wind energy constitutes more than 20% of the world's renewable energy [68]. **Fig 2.17** [68] below shows the global energy mix in 2018.



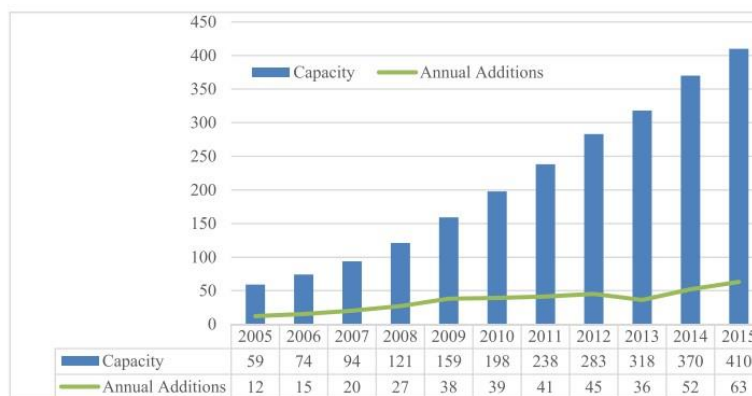
*Fig 2.17 Global energy mix in 2018*

Every country experiences wind and wind turbine can be set up offshore (in the sea or ocean) or onshore (on land). In 2017, wind energy consumption was 52% of global renewable energy while solar energy was 21% [69] [70]. Between 2008 and 2018, global cumulative wind capacity increased by fivefold as shown in **Fig 2.18** [69] below. Wind reserves are estimated to be above 400 million MW and the cumulative installed wind power capacity increased from 23 900 MW in 2001 to 651 000 MW in 2019 [67]. Wind farm of 50 kW installed capacity is classified as a small-scale wind energy [71].



**Fig 2.18** Global wind energy generation capacity

Reasons for dominance of wind over other renewable sources are as follows: Firstly, wind has an ability to generate large amounts of power at competitive costs [70] [69]. Secondly, wind energy has attracted a lot of interest because it is abundant, environmentally friendly due to lack of carbon emissions [72] [73]. Thirdly, generation costs of wind power declined from 2008 to 2015 which was achieved as result of increasing capacity factor such as larger tower with bigger blades for wind turbines rather than reducing the unit investment costs [74] [69]. **Fig 2.19** [33] below shows global investment of wind energy from 2005 to 2015 with capacity in GW.

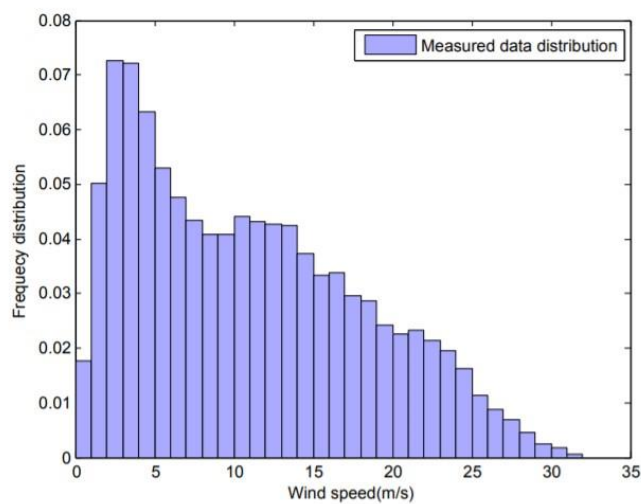


**Fig 2.19** Global increment in wind energy

Despite these, there are a lot of challenges of wind energy such as increasing public opposition against wind infrastructure.

### 2.3.1 Generation of wind power

There are certain steps that are required in order to generate wind power. Firstly, the wind energy potential for the area or region is assessed. This is done by finding meteorological wind energy potential quantifiers such as wind speed and wind direction. Wind resource assessment to find out the potential of wind energy in a particular location is the first in building wind farm. This is done in order to assess the profitability of wind energy production and reduce investment costs [66]. Wind speed frequency distribution from wind speed meteorological observation is crucial element that must be obtained for a particular area or region where the wind farm is to be constructed. Wind speed frequency distribution in the form of histogram which shown in **Fig 2.20** [66] below affects the estimation of Annual Energy Production(AEP) of a wind farm.



*Fig 2.20 Wind speed frequency distribution*

Probability distribution function (PDF) is the commonly used method for wind speed data assessment. The second method of wind resource assessment is Weibull distribution model which is a probability distribution function used for wind speeds over time duration [75] .

The wind power density(WPD) is used to calculate abundance of wind resource and potential of wind energy in ( $W/m^2$ ) is calculated by using the following parameters: wind speed at the turbine hub, roughness of the surface and the formula is as follows:

$$WPD = \frac{1}{2} \rho V^3 \quad (6) \text{ where:}$$

$V$  is wind speed at height,

$\rho$  is air density

Model output datasets from meteorological station give out wind speed which is measured at the wind turbine hub height of 10m. A wind turbine captures kinetic energy from the wind and converts it into electrical energy [76]. Both wind turbine output torque and power are expressed as follows:

$$P_m = \frac{1}{2} \rho C_p(\lambda) A V_w^3 [W] \quad (7) \text{ where } \rho \text{ is the air density (kg/m}^3\text{)}$$

R is the radius of the blade in metres;

$V_w$  is the wind speed (m/s);

A is the cross sectional area of the turbine;

$C_p(\lambda, \beta)$  is the power coefficient given by

$$C_p(\lambda, \beta) = \frac{1}{1} (\tau - 0.02\beta^2 - 5.6) e^{-0.17\tau} \quad (8) \text{ where:}$$

$$\tau = \frac{R(3600)}{\lambda(1609)} \quad (9)$$

and

$$\lambda = \frac{\omega_m R}{V_m} \quad (10)$$

$V_m$  is the rotor mechanical speed;  $\beta$

is the pitch of rotor blades;

Pitch control allows limiting of the generator power at wind speed higher than the rated speed.

However, there could be some cases where wind speed is measured at another height different from 10m, and this is done by extrapolating wind speed at certain hub height and speed at this new height is calculated [77] as follows :

$$v(z). \ln \frac{z_r}{z_0} = v(z_r). \ln \frac{z}{z_0} \quad (11)$$

where:

$z_r$  is the reference height (m);  $z$  the height where wind speed is to be determined (m);

$z_0$  is the measure of surface roughness (0.1–0.25 for crop land);  $v(z)$

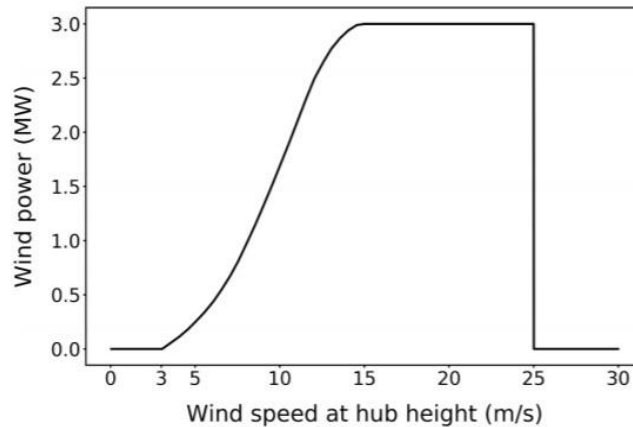
is the wind speed at height of Z m (m/s) and

$v(z_r)$  is the Wind speed at the reference height (m/s)

The value of  $z_0$  is taken as 0.1;

Weibull parameters are estimated to be  $K = 2$  and  $c = 3.9$  m/s.

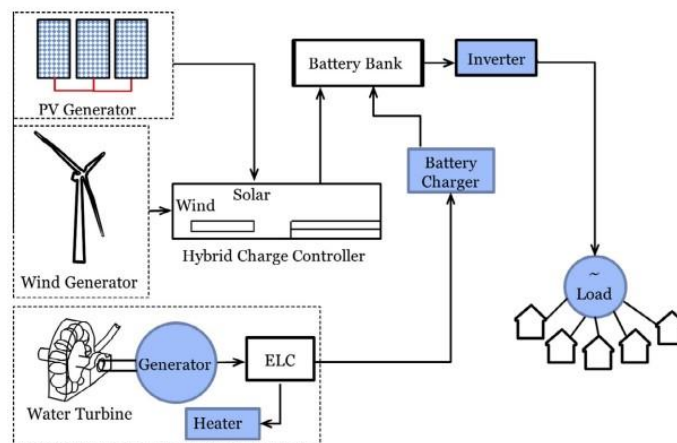
The wind power curve is shown in **Fig 2.21** [67] below at Cut in speed = 3.5 m/s, rated speed = 15 m/s, cut out speed = 25 m/s.



**Fig 2.21** Power curve of the hypothetical wind turbine model

## 2.4 Hybridization in a micro grid

Due to intermittency of renewable energy sources, hybrid system for production of energy combines various renewable energy technologies for complementing each other for continuous supply of power and improve power availability [78] in order to meet energy demand. Hybridization in a micro grid can be a combination of any of the following two or more technologies: Wind, hydro, PV modules, converter/inverter, controller and battery as a backup depending on the investment capital cost, preferred configuration and viability of such a solution at a particular area. Hybridization for micro grid systems may involve Photovoltaic and wind generators using hybrid charge controller (HCC) and the power from this controller is fed into battery bank to charge batteries as shown in **Fig 2.22** [79] below.



**Fig 2.22** Hybridization of wind, PV and hydro

There are different approaches of hybridization models such as optimization based on cost of energy (COE) using HOMER [80], GAMS 23.6 software with CPLEX solver along with

HOMER, which is a useful software for programming of micro grids and applied for size optimization [81]. The other hybrid model is to apply both Genetic Algorithm (GA) and HOMER Pro Software [9]. There are many research studies across the world that have been done about micro hybrid systems which are off-grid using HOMER software. The following are some of such research studies. Optimisation using HOMER was done on hybrid micro grid system of PV, diesel generator and battery off-grid in rural Tambo village which is in Adamawa state in North west Nigeria and was not connected to the grid, had load of 76 kWh/day, Peak of 14 kW and had Levelized Cost of Energy (LCOE) of US \$0.547 /kWh [82]. The other optimisation of hybrid system of the following configuration : PV, wind ,diesel generator and battery as backup system, using HOMER was for the remote village ,which was not connected to the grid, called Dembile in Bonke Woreda which is in SNNPR region in Ethiopia, with energy consumption of 279 kWh/day and peak of 64 kW, Levelized Cost of Energy was US\$0.538 /kWh [83]. The third hybrid of the following configuration : PV, diesel, inverter and battery as backup was modelled and optimised with HOMER for a small rural village called Makiyay in Southern State in Myanmar, with energy consumption of 100 kWh/day, peak was 34 kW and Levelized Cost of Energy was US \$0.429 /kWh [15]. In addition, the hybrid off grid system modelled and optimised with HOMER for a rural village called Pissila in Burkina Faso had the energy consumption of 711 kWh/day, peak of 81 kW had Levelized Cost of Energy of US\$ 0.5 /kWh [84]. Lastly a rural village in Siyambalanduwa District in Sri Lanka which was off grid and had energy consumption of 270 kWh/day with peak 25 kW had Levelized Cost of Energy of US \$0.34 /kWh[85].

## **Chapter 3: Methodology**

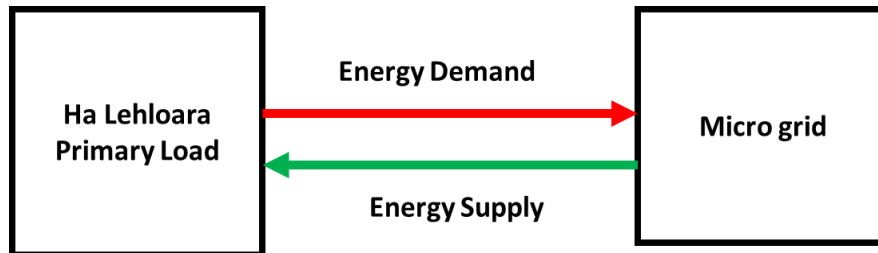
### **3.1 Daily Energy Consumption (Load Profile) of Ha Lehloara village**

The daily energy demand of Ha Lehloara village will be determined based on the number of households, energy consumption (wattage) of home appliances such as fridge, lightbulb, television and others, which are being used by each household. This will take into consideration the households, presence of schools and business entities in this village. The following assumptions will be taken into consideration in the evaluations: a certain number of households possess certain number of appliances. Furthermore, certain appliances such as television (TV) and radio are used for a certain number of the time. For instance, 1 means an appliance is used

100% of the time, 0.5 means an appliance is used 50% of the time while 0.1 means an appliance is used 10% of the time based on the need of the household. 0 means there is no usage of an appliance at the given time.

### 3.2 System Design to meet energy demand of Ha Lehloara village

The energy demand of Ha Lehloara village will be supplied by a design of micro grid as shown in Fig. 3.1 below.

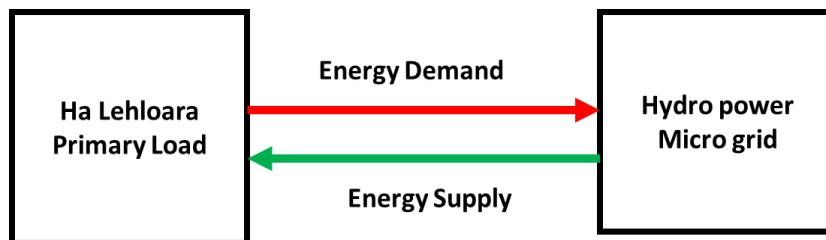


*Fig. 3.1 Micro grid supply to Ha Lehloara energy demand*

Micro grid for energy supply will be designed using hydro power, wind, solar and hybrid options.

#### 3.2.1 Hydro power micro grid

The design of hydropower micro grid is illustrated using block Fig. 3.2 below.



*Fig. 3.2 Hydropower micro grid supply to Ha Lehloara energy demand*

The hydro power micro grid generates electricity from water flow. This hydro power micro grid design will be based on the river flow data from Malibamatšo river. Meteorological data of Malibamatšo river flow obtained from Lesotho Highlands Development Authority (LHDA) will be used. Hydro electrical power output will be calculated using the following equation [86]:

$$P_{hyd} = \frac{\eta_{hyd} \rho_{hyd} g h_{net} Q_{turbine}}{1000W/kW} \quad (12)$$

Where:

$P_{hyd}$  = power output of the hydro turbine [kW]

$\eta_{hyd}$  = hydro turbine efficiency [%]

$\rho_{hyd}$  = density of water [1000 kg/m<sup>3</sup> ]  $g =$

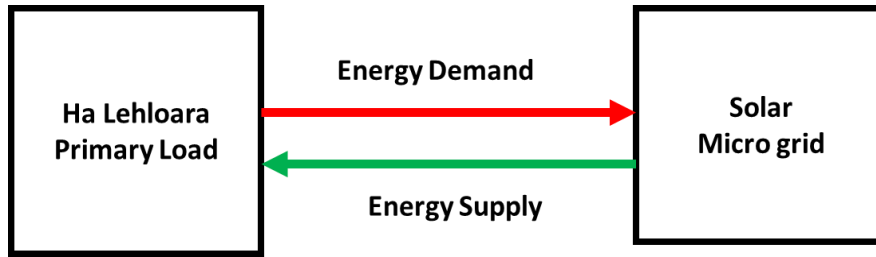
acceleration due to gravity [9.81 m/s<sup>2</sup> ]

$h_{net}$  = effective head [m]

$Q_{turbine}$  = hydro turbine flow rate [m<sup>3</sup>/s]

### 3.2.2 Solar micro grid

The design of solar micro grid is illustrated using Fig. 3.3 below.



*Fig. 3.3 Solar micro grid supply to Ha Lehloara energy demand*

Solar energy will be generated from amount of solar irradiance collected from the Sun. The amount of solar radiation for this project was obtained from NASA satellite using Ha Lehloara coordinates -28° 56' S and 28° 33' E (-28.949041<sup>0</sup>,28.556528<sup>0</sup>). After Daily Solar radiation and clearness index have been captured as input, the equation [86] below will be used to calculate the intensity of solar radiation at the top of the Earth's atmosphere.

$$G_{on} = G_{sc} \left( 1 + 0.033 \cos \frac{360n}{365} \right) \quad (13)$$

Where:

$G_{sc}$  is solar constant [1.367 kW/m<sup>2</sup>]

$n$  is the day of the year [1 – 365]

Extra-terrestrial radiation on horizontal

surface is calculated as follows:

$$G_o = G_{on} \cos \theta_z \quad (14) \text{ where:}$$

$G_{on}$  is intensity of solar radiation at the top of the Earth's atmosphere.

Zenith angle will be calculated by using the following equation:

$$\cos\theta_z = \cos\phi\cos\delta\cos\omega + \sin\phi\sin\delta \quad (15)$$

where:

$\omega$  is the hour angle[°]

$\delta$  is solar declination[°]

and solar declination is given by:

$$\delta = 23.45^\circ \sin\left(360^\circ \frac{284+n}{365}\right) \quad (16) \text{ where:}$$

$n$  is day of the year[1–365]

Daily radiation will be calculated by using the following equation:

$$H_o = \frac{24}{\pi} G_{on} \left[ \cos\phi\cos\delta\sin\omega_s + \frac{\pi\omega_s}{180^\circ} \sin\phi\sin\delta \right] \quad (17)$$

where:

$H_o$  is average extra-terrestrial horizontal radiation and

$\omega_s$  is sunset hour angle [°]

Sunset hour angle will be calculated as follows:

$$\cos\omega_s = -\tan\phi\tan\delta \quad (19)$$

Monthly average extra-terrestrial radiation [77] will be calculated as follows:

$$H_o = \frac{24 \times 3600 \times G_{sc}}{\pi} \left[ 1 + 0.033x \cos\left(\frac{360n}{365}\right) \right] \times (\cos\phi\cos\delta\sin\omega_s + \frac{\pi\omega_s}{180^\circ} \sin\phi\sin\delta) \quad (20)$$

Since temperature is another parameter that determines the amount of solar energy generated from the PV array, the temperature for this project will be obtained from NASA satellite using Ha Lehloara coordinates mentioned above. The PV cell temperature [87] will be calculated using the following equation:

$$T_c = T_a + (T_{c,NOCT} - T_{a,NOCT}) \left( \frac{G_T}{G_{T,NOCT}} \right) \left( 1 - \frac{n_{mp}}{\tau\alpha} \right) \quad (21)$$

where:

$T_c$  is the PV cell temperature in °C

$T_a$  is the ambient temperature

$G_T$  is the solar radiation incident on the PV array in kW/m<sup>2</sup>

$\tau$  is the solar transmittance over the PV array in percentage

$\alpha$  is the solar absorptance of PV array in percentage

$T_{c,NOCT}$  is the nominal operating cell temperature in °C

$T_{a,NOCT}$  is the ambient temperature at which NOCT is 20 °C

$G_{T,NOCT}$  is the solar radiation at which NOCT is defined i.e. 0.8 kW/m<sup>2</sup>

$n_{mp}$  is the efficiency of the PV array at its maximum power point [%]

Solar irradiance is captured by PV module which in turn gives the PV power. The size of the system will depend on the number of PV modules that will be used and number of modules will depend on the daily energy consumption of this village. In addition, there is correlation between PV cell temperature and the PV array power output. The power output of each PV panel will be determined using the following formula [88] [86] :

$$P_{pv}(kW) = P_{rated}(kW) * Y_{pv} * \left(\frac{G}{G_{ref}}\right) * [1 + k_T(T_c - T_{ref})] \quad (22)$$

where:

$P_{pv}(kW)$  is the power output of PV array

$P_{rated}(kW)$  is the rated power of PV array, meaning its power output under standard test conditions [kW]

$Y_{pv}$  is the PV derating factor [%]

$G$  is the solar radiation incident on the PV array in the current time step [kW/m<sup>2</sup>]

$G_{ref}$  is solar irradiance at standard temperature test conditions [1 kW/m<sup>2</sup>]

$T_c$  is the PV cell temperature in the current time step [°C]

$T_{ref}$  is the PV cell temperature under standard test conditions [25 °C]

$k_T$  is the temperature coefficient of power [%/°C]

The total number of PV modules will be determined by using the following equation [88]:

$$N_{PV} = N_{PVs} + N_{PVp} \quad (23) \text{ where:}$$

$N_{PVs}$  represent number of PV modules in series

$N_{PVp}$  represent number of PV modules in parallel

The annual total PV energy of solar panel will be calculated as [88]:

$$E_{PV} = \sum_{t=1}^{8760} [P_{PV}(t)] \quad (24)$$

where:

$E_{PV}$  is the annual total PV energy

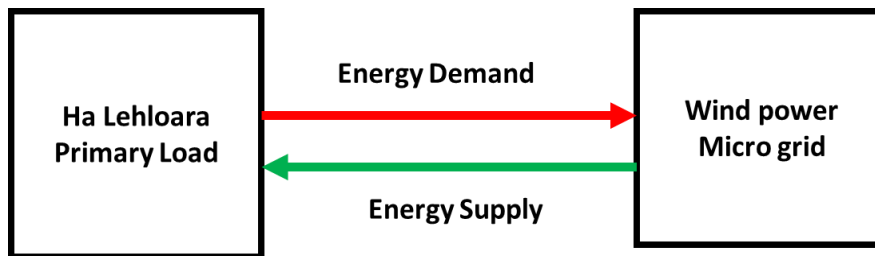
$P_{PV}(t)$  is power output of PV cell

After having found the solar profile of Ha Lehloara village, the PV module as the component for this solar profile will be chosen in order to address the load profile of this village. The PV power output depends on the efficiency of the PV module, which is between 9% to 17%. This

(efficiency) is usually low and the current as well as the voltage for PV are affected by the environmental variables such as temperature and irradiance. Low efficiency results in energy loss especially during cloudy days [89]. Therefore, the PV panels need Maximum Power Point Tracker (MPPT) in order to increase efficiency of the PV module and also take care of the battery bank [90].

### 3.2.3 Wind micro grid

The design of wind micro grid is illustrated in Fig. 3.4 below.



*Fig. 3.4 Wind micro grid supply to Ha Lehloara energy demand*

The wind speed data will be obtained from NASA satellite for Ha Lehloara coordinates - 28° 56′ S and 28° 33′ E (-28.949041<sup>0</sup>, 28.556528<sup>0</sup>). The wind speeds for Ha Lehloara will be extrapolated at hub height 40 m using formula [77]:

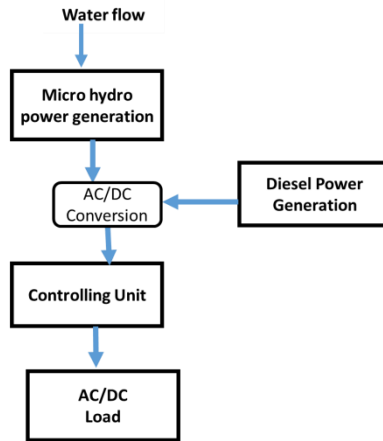
$$v(z). \ln \frac{z_r}{z_0} = v(z_r). \ln \frac{z}{z_0} \quad (22)$$

### 3.2.4 Hybrid Options

After modelling designs that depend only on one resource such as water, wind and solar, these resources will be combined to form hybrid micro grid using different block diagrams for addressing energy demands at Ha Lehloara village as shown below.

#### a) Hydro/diesel generator

The design of hybrid hydro and diesel generator micro grid is illustrated in Fig 3.5 below.

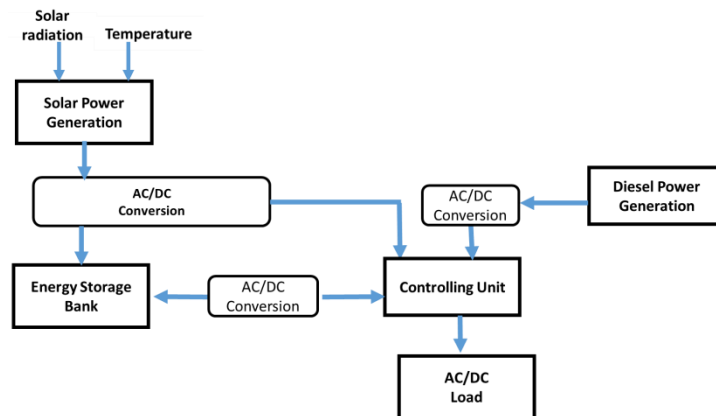


*Fig 3.5 Hydro/generator micro grid*

This design will be based on hydro power in the hybrid micro grid for supplying energy to the village with diesel generator as a backup power source.

**b) Solar/generator hybrid micro grid**

The design of hybrid solar and diesel generator micro grid is illustrated in Fig 3.6 below.

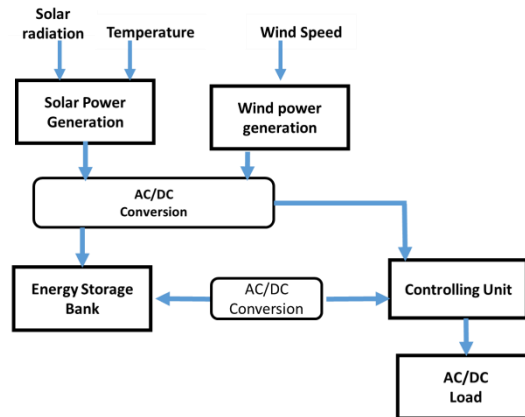


*Fig 3.6 Solar and generator hybrid micro grid*

This design will be based on solar radiation as renewable energy resource for generation of solar energy in the hybrid micro grid for supplying energy to the village with energy storage for power in case of power failure and diesel generator serves as power backup source.

**c) Solar/wind hybrid micro grid**

The design of the hybrid of solar and wind micro grid is illustrated Fig. 3.7 below.

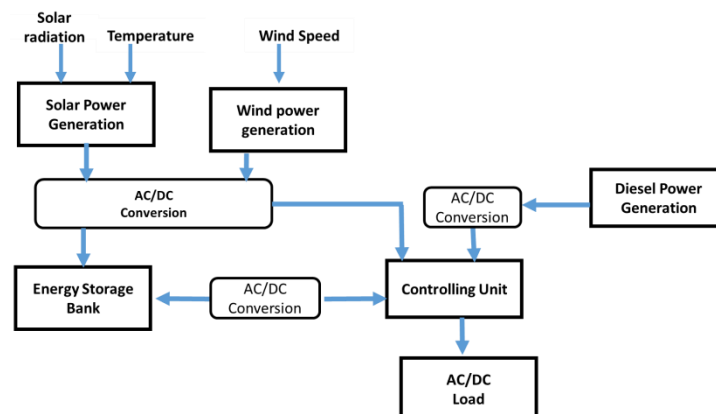


*Fig 3.7 Solar/wind hybrid micro grid*

This design will be based on solar and wind as renewable energy resources in the hybrid micro grid for supplying energy to the village with energy storage for power in case of power failure.

**d) Solar/wind/generator hybrid micro grid**

The design of solar, wind and diesel generator hybrid micro grid is illustrated in Fig. 3.8 below.

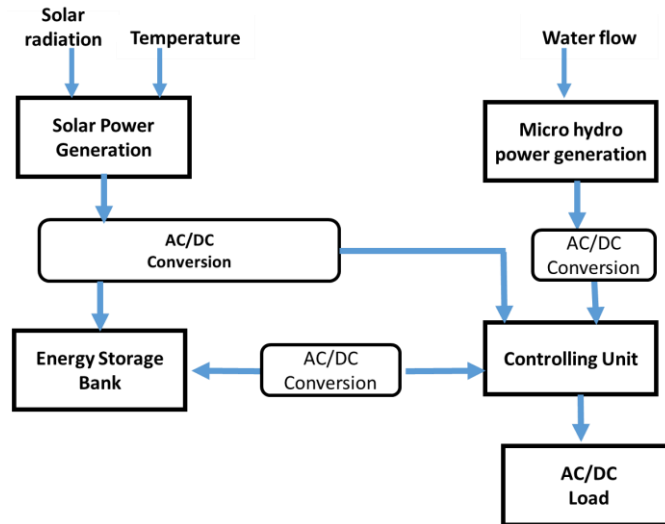


*Fig 3.8 Solar/Wind/diesel generator hybrid micro grid*

This design will be based on solar and wind as renewable energy resources in the hybrid micro grid for supplying energy to the village with energy storage for power in case of power failure and diesel generator as a backup power source.

**e) Solar/hydro hybrid micro grid**

The design of the hybrid of solar and hydro micro grid is illustrated in Fig 3.9 below.

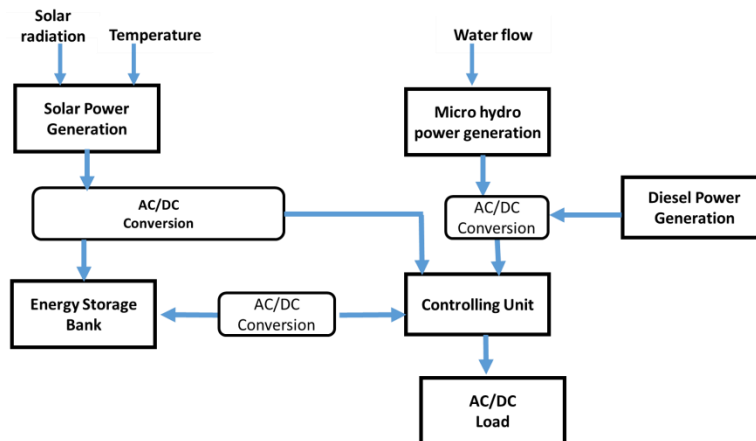


*Fig 3.9 Solar/hydro hybrid micro grid*

This design will be based on solar/hydro power in the hybrid micro grid for supplying energy to the village with energy storage for power in case of power failure.

**f) Solar/hydro/generator hybrid micro grid**

The design of hybrid solar and hydro micro grid is illustrated in Fig. 3.10 below.

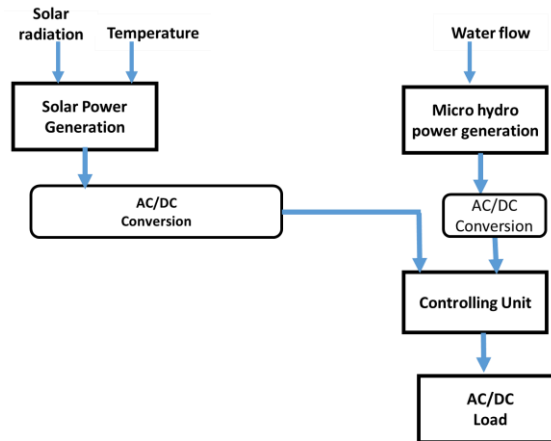


*Fig 3.10 Solar/hydro/energy storage/generator hybrid micro grid*

This design will be based on solar and hydro power in the hybrid micro grid for supplying energy to the village with energy storage for power in case of power failure and diesel generator as a backup power source.

### g) Solar/hydro without energy storage hybrid micro grid

The design of hybrid solar and hydro without energy storage micro grid is illustrated in Fig. 3.11 below.

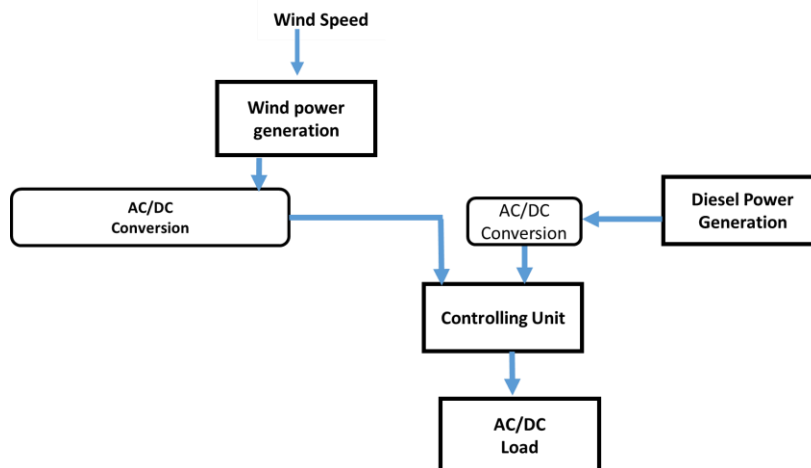


*Fig 3.11 Solar/hydro/ hybrid micro grid*

This design will be based on solar and hydro power in the hybrid micro grid for supplying energy to the village without any energy.

### h) Wind/generator hybrid micro grid

The design of hybrid wind and diesel generator hydro micro grid is illustrated in Fig 3.12 below.

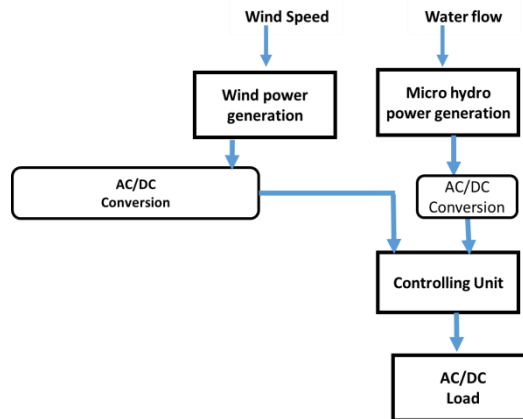


*Fig 3.12 Solar/Wind/diesel generator hybrid micro grid*

This design will be based on wind renewable energy resource in the hybrid micro grid for supplying energy to the village with diesel generator as a backup power source.

### i) Hydro/wind hybrid micro grid

The design of hybrid hydro and wind micro grid is illustrated in Fig 3.13 below.

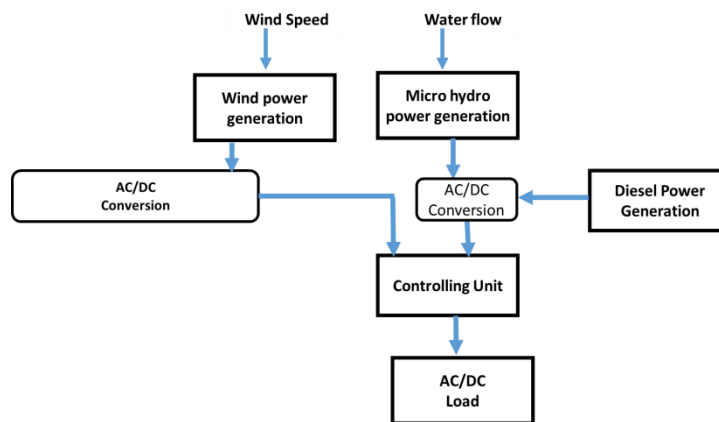


**Fig 3.13** Hydro/Wind micro grid

This design will be based on hydro and wind in the hybrid micro grid for supplying energy to the village.

**j) Hydro/wind/generator hybrid micro grid**

The design of hybrid hydro, wind, battery storage and generator micro grid is illustrated in Fig 3.14 below.

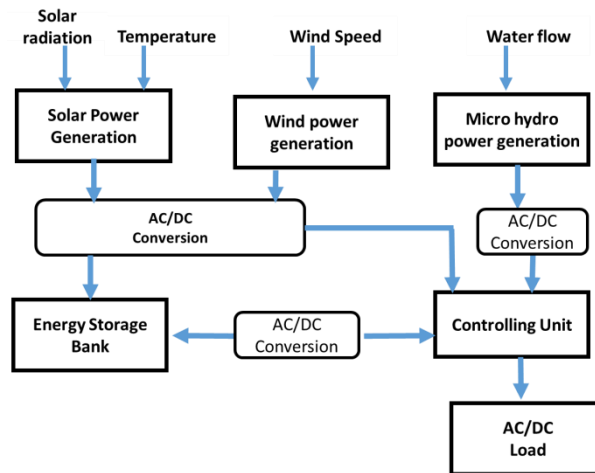


**Fig 3.14** Hydro/Wind/Generator micro grid

This design will be based on hydro and wind as renewable energy resources in the hybrid micro grid for supplying energy to the village with energy storage for power and diesel generator as backup in case of power failure.

**k) Solar/hydro/wind hybrid micro grid**

The design of hybrid solar, hydro and wind micro grid is illustrated Fig 3.15 below.

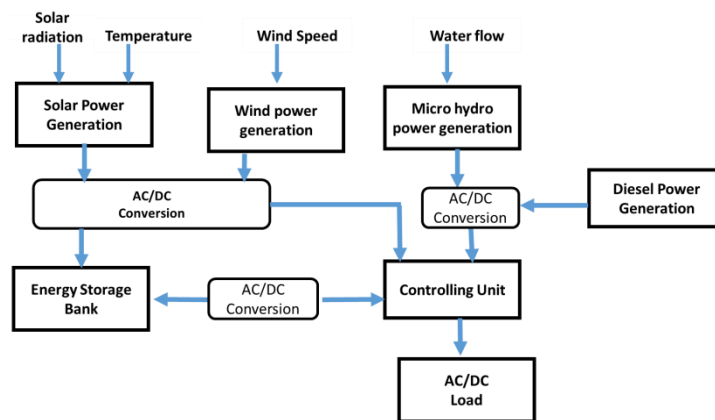


*Fig 3.15 Solar/hydro/wind/energy storage hybrid micro grid*

This design will be based on solar radiation, wind, solar and hydro power in the hybrid micro grid for supplying energy to the village with energy storage in case of power failure.

### **1) Solar/hydro/wind/ generator hybrid micro grid**

The design of hybrid solar, hydro, wind and generator micro grid is illustrated in Fig. 3.16 below.



*Fig.*

*3.16 Solar/hydro/wind/generator hybrid micro grid*

This design will be based on solar, hydro and wind as renewable energy resources for supplying energy to the village with energy storage for power in case of power failure and diesel generator as backup in case all the other sources fail as a result of their intermittency nature.

### **3.3 Economic model of the designed system**

The economic design of the system design will include particular variables such as system constrains, inflation, discount rate and other constraints so that the following functions can be determined during modelling and optimizing of the hybrid micro grid system at Ha Lehloara:

Net Present Value (NPV), Payback period, total capital costs, total replacements costs, total O/M costs and most Levelized Cost of Energy (LCOE). Furthermore, sensitivity analysis will be carried out for each specific option /system configuration in order to make informed investment decisions in the project of building hybrid micro grids in the rural villages of Lesotho with Ha Lehloara as a study case.

### 3.3.1 Cost of Energy (LCOE)

Cost of Energy is used to measure the economic viability of the systems and which is expressed in \$/kWh is calculated using the following formula:

$$LCOE = \frac{NPC}{\sum_1^{8760} P_{load}} \times CRF \quad (26)$$

where:

*NPC is Net Present Cost or is the total annualized cost of the system;*

The net present cost of any component system is the present value of all the costs of installation, operations and maintenance costs of a component over its life time minus the present value of all the cash flows that it generates over the project lifetime.

*P<sub>load</sub> is the hourly power*

*CRF is capital Recovery Factor [91] and is expressed as:*

$$CRF = \frac{i(1+i)^n}{(1+i)^n - 1} \quad (27)$$

where:

*i* is the annual interest; *n*

is the number of years;

The relationship between inflation rate, nominal interest and real interest rate is expressed as follows:

$$r = \frac{i-f}{1+f} \quad (28)$$

where:

*r* is real interest rate, *i* is

nominal interest rate, *f*

is inflation rate.

### 3.3.2 Net Present Value

The feasibility, viability and profitability of any project is measured by determining whether

NPV is negative or positive. Positive NPV means a project is viable and negative NPV means a project is not viable and therefore cannot be undertaken. Therefore, NPV in this study will be used to determine whether this hybrid micro grid is feasible and profitable for investors. NPV is the very good indicator that determines the value for money for an investor. On the other hand, NPC is normally a good measure for micro grids project because it can be used even if there is no revenue generated from such a project compared to NPV which is based on cash flows as a revenue for the project and more importantly an investor.

The formula for NPV [92] is as follows:

$$NPV = \sum_{n=0}^N \frac{F_n}{(1+r)^n} \quad (29)$$

Where:

$NPV$  is Net Present Value;

$F_n$  is annual cash flow from the project

$N$  is number of years of the project

$r$  is annual discount rate

The relationship between discount rate and inflation rate is as follows:

$$r = \frac{(1+i)}{(1+f)} - 1 \quad (30)$$

where:

$r$  is the discount rate  $f$  is

inflation rate  $i$  is nominal

discount rate

### 3.3.3 Net Present Cost

The net present cost (or life-cycle cost) of a system is the present value of all installation, operation and maintenance costs of the system components lifetime of project, minus the present value of all total revenue that accrues to the project over its lifetime. HOMER calculates the net present cost as follows:

$$NPC = \frac{C_{annual,total}}{C_{CRF}(r,R_{project})} \quad (31)$$

where:

$C_{annual,total}$  is the total annual cost

$R_{project}$  is the number of years of project/project life time

$r$  is real interest rate,

Return of investment [16] from a project over its number of years is calculated as follows:

$$C_{RF(r,n)} = \frac{r(1+r)^n}{(1+r)^n - 1} \quad (32)$$

where:

$r$  is real interest rate,

$n$  is number of years of project,

For this Hybrid micro grid at Ha Lehloara, NPC [93] will also be expressed as follows:

$$NPC = (N_{pv}C_{tot} + N_{wt}C_{tot} + N_{ht}C_{tot} + N_{batt}C_{tot} + C_{gen} + C_{inv} - C_{salvage}) \quad (33)$$

$$C_{tot} = C_{cap} + C_{mnt} + C_{rep} \quad (34) \text{ where:}$$

$N_{pv}$  is number of PV modules

$N_{wt}$  is number of wind turbines

$N_{ht}$  is number of hydro turbines

$N_{batt}$  is number of batteries

$C_{gen}$  is cost of generator

$C_{inv}$  is cost of inverter

$C_{tot}$  is total cost

$C_{cap}$  is capital cost

$C_{rep}$  is replacement cost

$C_{salvage}$  is salvage value at the end of project lifetime

Discount factor which is used to calculate the present value of the cash flow that occurs annually for the life time of a project is calculated as follows:

$$f_d = \frac{1}{(1+i)^N} \quad (35)$$

$f_d$  is discount factor

$i$  is real discount rate (%)

$N$  is project life time

### 3.3.4 Salvage value

Salvage value which is sometimes called residual value is calculating depreciation value of capital or replacement costs [93] of a component and the formula is as follows:

$$SV = C_{rep} \cdot \frac{R_{rem}}{R_{comp}} \quad (36)$$

where:

$$R_{rem} = R_{comp} - (R_{proj} - R_{rep}) \quad (37)$$

where:

$R_{rem}$  is lifetime of a component

$R_{proj}$  is lifetime of a project

$R_{rep}$  is duration of replacement cost

$C_{rep}$  is replacement cost

### 3.3.5 Payback Period

Payback period determines the number of years it will take to repay loans granted for the implementation of the project. The payback determines the length of period it will take to recover investment costs of the project as measured against the base case system. The formula for payback period [93] is as follows:

$$PB = \frac{IV + TC_{rep} + TC_{OM} - SV}{SG_{annual}} \quad (38)$$

where:

$IV$  is initial investment (Capital costs plus installation costs)

$TC_{rep}$  is the total replacement costs

$TC_{om}$  total operation and maintenance costs

$SV$  is salvage value. For any component that still has some lifetime remaining at the end of the project lifetime, salvage value is positive.

$SG_{annual}$  is annual savings

### 3.3.6 Internal rate of return

Internal rate of return (IRR) is the discount rate at which the value of the Net Present Cost of the base case system and value of the Net Present Cost of the current system is the same. At the point where the two values of the Net Present Cost are the same, the discount rate makes the difference between the present value and the cash flows, to be equal to zero.

## 3.4 Implementation of system using HOMER

The first step in the implementation of this system design is to compute the load profile for energy demand for Ha Lehloara village in HOMER PRO software based on the assumptions made in section 3.1. Secondly, modelling of all of the various systems configurations will be done using HOMER PRO. Lastly, optimisation of the results of various system design options

will be implemented for each system configuration in order to determine the best system for technical and economic viability.

The implementation will assess both technical and economic model of each system configuration in order to identify the best optimised system configuration.

#### **3.4.1 Modelling of system configuration**

The Hydro power micro grid will be modelled in HOMER PRO by determining, the lowest annual flow rate of Malibamatšo river and net head. The capital, replacement, operating and maintenance costs for this hydro turbine will be assessed. Furthermore, the civil costs for constructing weir for hydro power generation will be evaluated. Secondly, solar micro grid for Ha Lehloara will be modelled in HOMER PRO by evaluating the average solar radiation and clearness index, average monthly temperature, average monthly temperature. The capital, replacement, operating and maintenance of PV modules will be assessed, taking into consideration the Parameters of the Datasheet. The required storage will be used to determine the size of the battery bank required for this system. For example, if the load is Y kWh/day and assuming that the battery bank will store energy for two days, the total energy that will be stored will be  $Y \times 2$  kWh. Thirdly, wind micro grid for Ha Lehloara will also be modelled in HOMER PRO by determining the average wind speed index after extrapolation at hub height of 40 m and the wind profile curve will be drawn. Lastly, in the modelling of the various options of the hybrid micro grid system configurations in HOMER PRO, the combination of components already mentioned in hydro, solar and wind micro grids will be used, depending on the renewable energy resources in each hybrid model and without any redundancy of components. Any additional components per option, will be highlighted in the results section.

#### **3.4.2 Optimisation of the results**

The implementation will assess both technical and economic model of each system configuration in order to identify the best optimised system configuration. Optimisation of the results from modelling will be done by subjecting results to the following economic parameters: Net Present Value(NPV), Net Present Cost(NPC), Internal Rate of Return(IRR),

Payback Period, Return on Investment (ROI). A system configuration will be said to be optimised if it has Lowest Cost of Energy (LCOE), greatest NPV, highest IRR that is greater than interest rate, smallest Payback period, larger ROI, and smallest NPC when compared to other system configurations. Lastly, results will also be technically optimised by assessing energy renewable fraction, amount of carbon emissions, excess electricity, electricity capacity shortage, unmet electric load percentage. A system configuration will be considered technically optimised if the load has lowest electricity consumption, 0% unmet electric load and 0% capacity shortage, highest energy renewable fraction. In summary, a preferred system configuration must be the one that is both economically and technically optimised.

## Chapter 4: Results and Discussion

All cost calculations were based on the South African Africa Rand currency with the exchange rate of one United States of America dollar being taken as equivalent to fifteen South African Africa Rand (USD \$ 1= R15.00). For this study, the default economic values for every system configuration (implementation) in HOMER PRO has nominal discount rate of 8.20 %, expected inflation rate of 5.00% which both yield the real discount rate of 3.05% for project lifetime of 25 years. The inflation for Lesotho is around 5.0% while discount rate is 8.2 % according to Central Bank of Lesotho report of 2019/2021 [94]. The results will be in the following order: firstly, results of demand profile and renewable energy resources will be shown. Secondly, results of various system hybrid configurations from implementation using HOMER PRO software will be shown in this section. Lastly, discussion and analysis of these results will follow in order to identify the best optimised system configuration for technical and economic feasibility and viability.

### 4.1 Results for Energy Consumption (Load Profile) of Ha Lehloara village

Ha Lehloara village has hundred (100) households. The results for its energy consumption (load profile), obtained from the Department of Rural Water Supply (DRWS) web portal [95], are shown in **Table 4.1** and **Table 4.2** below. Since Ha Lehloara is a rural village, its daily energy demand profile will conform to ‘double-hump’ variation [96], which has the shape of a graph of daily energy consumption for rural village. The total energy consumption, was subjected to HOMER load profile for Residential in **Table 4.3**. The Random variability of Day-to-day of 5% for the load profile results in Peak of 67.30 kW. With this 5% variability, the average energy is 15.24 kW, which results in load factor of 0.23, obtained by dividing average energy by peak load, that is,  $\frac{15.24 \text{ kW}}{67.30 \text{ kW}} = 0.23$ . The load profile graphs for different periods are respectively illustrated in **Fig. 4.1**, for daily profile, **Fig. 4.2**, for seasonal profile and **Fig. 4.3**, for yearly profile:

**Table 4.1** Appliances and power units

No.	Appliance type	Number in Use	Number of houses	Total	Power (Watts)	Total Power (Watts)
<b>Domestic(House) appliances load</b>						
A1	Energy saver lights	4	100	400	7	2800
A2	Refrigerators	1	30	30	240	7200

A3	iron	1	40	40	1200	48000
A4	Radio/Speakers	1	100	100	100	10000
A5	TV	1	30	30	60	1800
A6	Computer	1	20	20	100	2000
A7	stove plates	1	30	30	1000	30000
A8	cell phone	5	100	500	6	3000
A0	Electric Kettle	1	100	100	1200	120000
		<b>Shop appliances</b>				
A9	Energy saver lights	4	1	4	10	40
A10	Refrigerators	3	1	3	240	720
A11	Radio/Speakers	1	1	1	100	100
A12	TV	1	1	1	60	60
A13	Computer	1	1	1	100	100
A14	cell phone	5	4	20	6	120
		<b>School appliances</b>				
A15	Energy saver lights	4	100	400	10	4000
A16	Refrigerators	2	1	2	240	480
A17	iron	1	0	0	1200	0
A18	Radio/Speakers	1	0	0	100	0
A19	Computer	1	200	200	100	20000
A20	Till Machine	1	0	0	100	0

**Table 4.2** Daily load Profile of Ha Lehloara

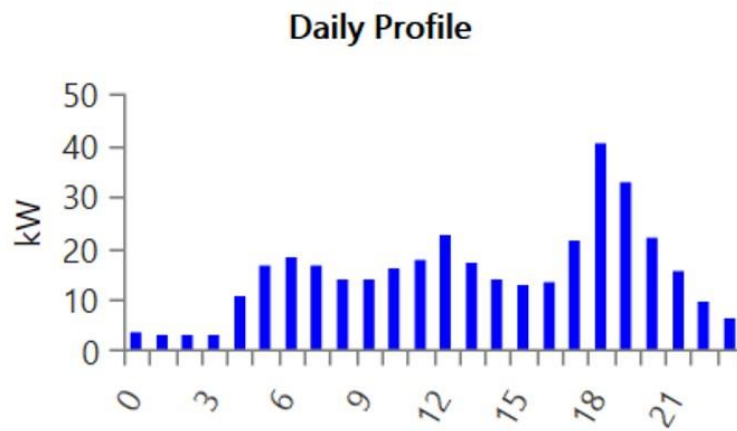
HR	A1	A2	A3	A4	A5	A6	A7	A8	A9	A10	A11	A12	A13	A14	A15	A16	A17	A18	A19	A20	total Energy(w)	Total Energy (kw)	
0	0.1	0.1	0	0	0	0	0	0	0	1	0.1	0	0	0	0	0.2	0.1	0	0	0	0	3576	3.58
1	0.1	0.1	0	0	0	0	0	0	0	0.1	0.1	0	0	0	0	0.1	0.1	0	0	0	0	3122	3.12
2	0.1	0.1	0	0	0	0	0	0	0	0.1	0.1	0	0	0	0	0.1	0.1	0	0	0	0	3122	3.12
3	0.1	0.1	0	0	0	0	0	0	0	0.1	0.1	0	0	0	0	0.1	0.1	0	0	0	0	3122	3.12
4	0.7	0.1	0	0	0	0	0	0	0	0.9	0.2	0	0	0	0	0.9	0.5	0	0	0	0	10738	10.74
5	0.5	0.1	0	0.1	0	0	0	0	0	0.5	1	0.6	0	0	0	0.5	0.8	0	0.1	0	0	16422	16.42
6	0	0.2	0	0.1	0	0	0	0.1	0	0	0	0.2	0	0	0	0	0	0	0.1	0	0	18060	18.06
7	0	0.1	0	0.1	0	0	0	0.1	0	0	0.2	0.4	0	0	0	0	0.5	0	0.1	0	0	16424	16.42
8	0	0.1	0.1	0	0	0	0	0	0	0	0.3	0	0	0	0	0	1	0	0	0	0	13776	13.78
9	0	0.6	0	0	0	0	0	0	0	0	0.1	0	1	1	1	0	0	1	0	0.1	0	14132	14.13
10	0	0.1	0	0	0.1	0	0	0	0	0	0.1	0	0.1	0.1	0.1	0	0.1	1	0	0.7	0	16250	16.25
11	0	0.1	0	0.1	0.5	0	0	0	0	0	0.1	0.1	1	1	1	0	0.3	1	0.1	0.3	0	17514	17.51
12	0	0.1	0	0.1	0.1	0	0	0	0	0	0.1	0.1	1	0.8	1	0	0.1	1	0.1	0.6	0	22686	22.69
13	0	0.1	0	0.1	0	0	0	0	1	0	0	0	0	0.4	0	0	0	1	0.1	0.2	0	17040	17.04
14	0	0.1	0	0.1	0	0	0	0	0.5	0	0.1	0.1	1	0.3	0	0	0.1	1	0.1	0.1	0	13736	13.74
15	0	0.1	0	0.1	1	0	0	0	0.3	0	0.1	0.1	0	1	0	0	0.1	0	0.1	0.1	0	13026	13.03
16	0	0.1	0	0.1	1	0	0	0	0.5	0	0.1	0.1	0	0.3	0	0	0.1	0	0.1	0.1	0	13416	13.42
17	0.5	0.1	0	0.1	0.1	0	0	0.1	0.4	0.1	0.1	0.1	0	0	0	0.1	0.5	0	0.1	0.1	0	21608	21.61
18	0.4	0.3	0	0.3	0.1	0.1	0.1	0.1	0.2	0.1	0.1	0	0	0	0	0.2	0.1	0	0.3	0.1	0	40458	40.46
19	1	0.3	0	0.1	0.4	0.1	0.1	0	1	0.6	0.1	0	0	0	0	1	0.6	0	0.1	0.1	0	32926	32.93
20	1	0.1	0	0.1	0.3	0.1	0	0	1	0.1	0.1	0	0	0	0	1	0.1	0	0.1	0.1	0	22226	22.23
21	0.2	0.6	0	0	1	0	0	0	0	0.2	0.2	0	0	0	0	0.2	0.3	0	0	0	0	15748	15.75
22	0.3	0.3	0	0	0	0	0	0	0	0.3	0.8	0	0	0	0	0.3	0.8	0	0	0	0	9846	9.85
23	0.1	0.3	0	0	0	0	0	0	0	0.1	0.1	0	0	0	0	0.1	0.1	0	0	0	0	6700	6.70
																						365.67	

**Table 4.3** Hourly Profile of Ha Lehloara

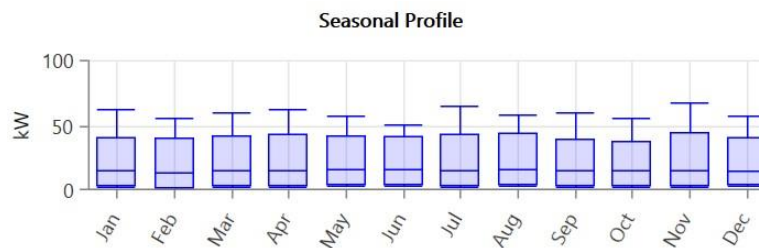
Hour	Load (kW)
0	3.576
1	3.122
2	3.122
3	3.122
4	10.738
5	16.422
6	18.06
7	16.424

8	13.776
9	14.132
10	16.25
11	17.514
12	22.686
13	17.04
14	13.736
15	13.026
16	13.416
17	21.608
18	40.458
19	32.926
20	22.226
21	15.748
22	9.846
23	6.70

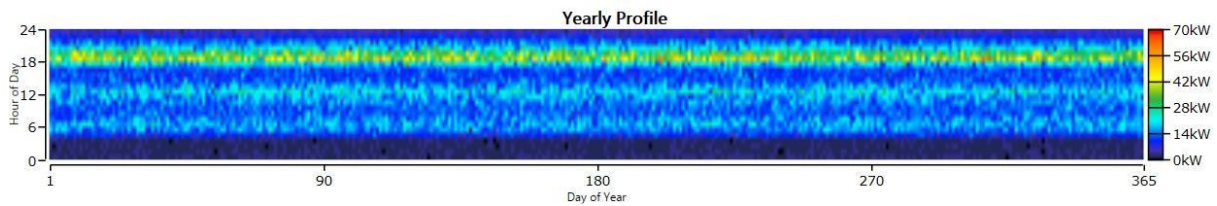
Average = **15.24 kW**



**Fig 4.1** 'Double-hump' daily energy demand profile



**Fig 4.2** Seasonal Profile



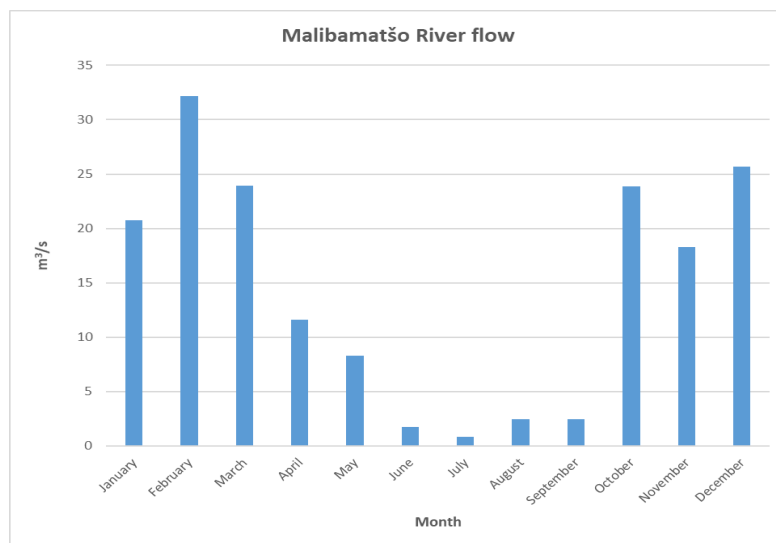
**Fig 4.3** Yearly Profile

The total daily energy consumption or daily primary load of Ha Lehloara village is 365.67 kWh/day and average energy consumption per household is 3.66 kWh/day while the peak load per day is 67.3 kW.

## 4.2 Hydro power micro grid

### 4.2.1 Water resource for hydropower micro grid

The results of Malibamatšo river flow are shown in **Fig. 4.4** below. The river flow is higher from October to March and lower from April to September.



**Fig 4.4** Malibamatšo river flow

The lowest annual flow rate is 0.82 m<sup>3</sup>/s and will be used for hydropower generation for supplying load at Ha Lehloara. Near this village Malibamatšo lies between the contours of 2175 m and 2150 m. Therefore, the gross head of this hydro plant will be 2175 - 2150 = 25 metres.

Fig 4.5 shows the system configuration for hydro micro grid for the supply of energy to Ha Lehloara. The Francis micro hydro turbine (HL 220-WJ-30) with 100 kW is chosen for this study) because of its lower purchase cost compared to other models.

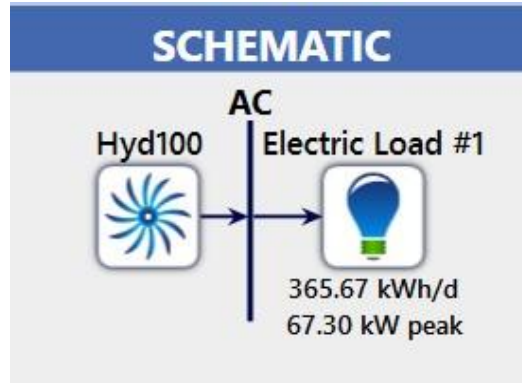


Fig 4.5 Micro hydropower system configuration

The purchase price of this hydro turbine that will be used for this study is USD \$35,000 to \$66,000 [97]. Since there will be civil works, the total capital cost will be around \$1 000 000 which is equivalent to R 15 300 000. **Table 4.4** below shows the datasheet of the 100 kW hydro Francis turbine [97].

**Table 4.4** Datasheet of 100 kw hydro Francis turbine

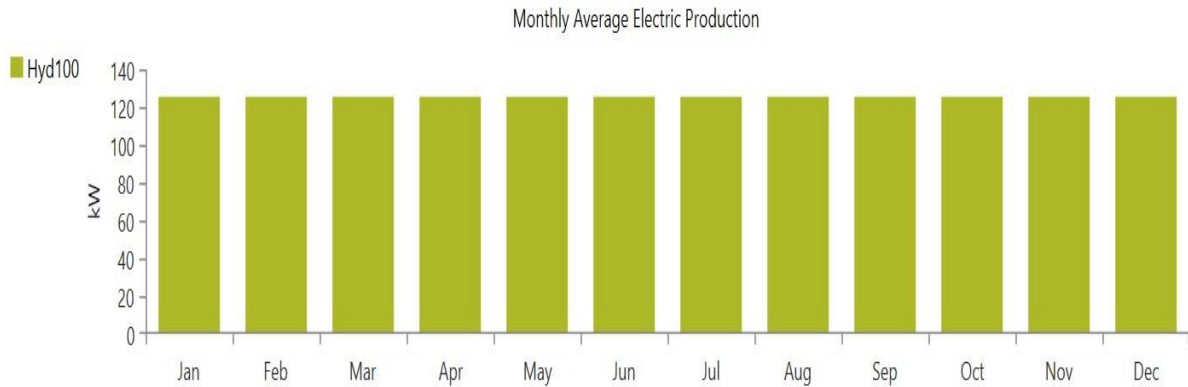
Turbine Parameters				General Parameters	
Design Head	Flow rate	Output (kw)	Design speed (r/min)	Power (kW)	Rated speed
11	0.33	32	774	25	750
12	0.34	36	808	30	
13	0.36	41	841	35	
20	0.44	78	1043	60	100
0.48	103	1143	100	1000	
0.5	116	1190	100	1000	

**Fig 4.6** below shows the optimisation results from HOMER software. These results show that only hydro micro grid is used to supply 100% of energy at cost of R12.15/kWh.

Optimization Results									
Left Double Click on a particular system to see its detailed Simulation Results.									
Architecture				Cost				System	
Hyd100 (kW)	Efficiency1	Dispatch	COE (R)	NPC (R)	Operating cost (R/yr)	Initial capital (R)	Ren Frac (%)	Total Fuel (L/yr)	
98.1	0	LF	R12.15	R28.1M	R755,000	R15.0M	100	0	
98.1	1.00	LF	R12.15	R28.1M	R755,000	R15.0M	100	0	
98.1	1.00	CC	R12.15	R28.1M	R755,000	R15.0M	100	0	
98.1	0	CC	R12.15	R28.1M	R755,000	R15.0M	100	0	

**Fig 4.6** Micro hydropower output from HOMER

**Fig 4.7** below shows uniform monthly average electricity production from hydro micro grid. The village load demand of 365.67 kwh/day is fully met by hydro power and there is an annual excess of electricity of 88% as shown in Table 4.5.

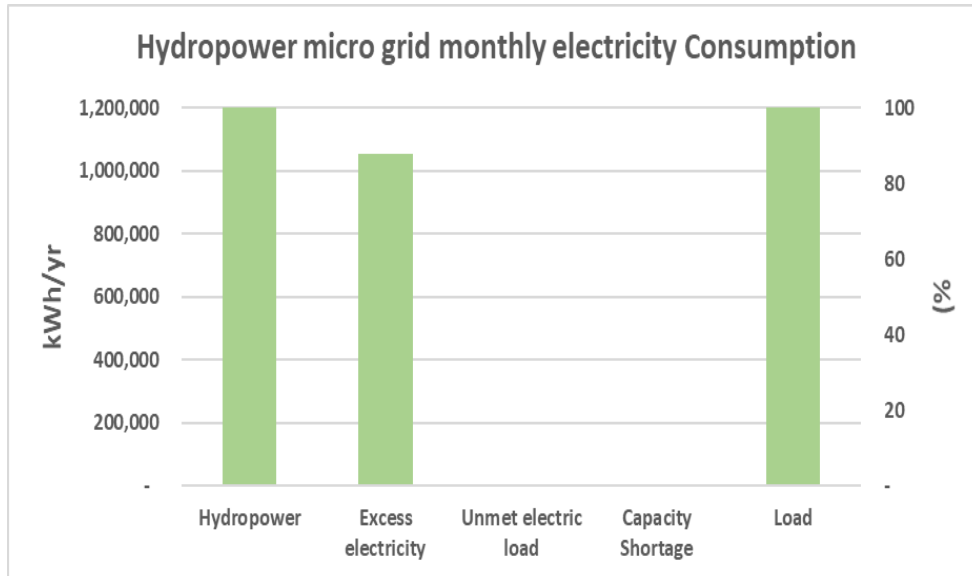


**Fig 4.7** Micro hydropower Monthly electricity production

**Table 4.5** below shows the average monthly electricity consumption and **Fig 4.8** displays the same data pictorially, confirming that 100% of the load demand is met by hydro power.

**Table 4.5** Hydropower micro monthly electricity Consumption

	kWh/yr	%
Hydropower	1,095,679	100
Excess electricity	962,206	88
Unmet electric load	-	-
Capacity Shortage	-	-
Load	133,470	100

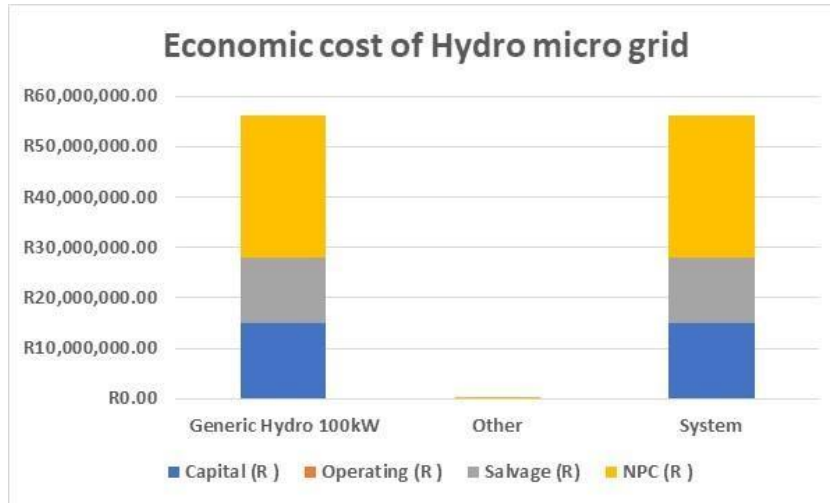


**Fig 4.8** Micro hydropower Monthly electricity consumption

**Table 4.6** and **Fig 4.9** below show the cost of the hydropower micro grid system, of which the total cost is R28 077 440.99 and the LCOE is R12.15/kWh.

**Table 4.6** Hydropower micro grid total cost

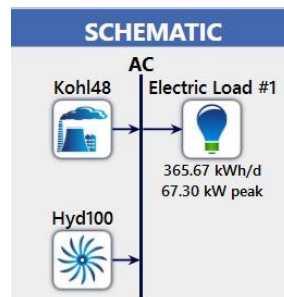
System Configuration	Capital (R )	Operating (R )	Salvage (R)	NPC (R )	LCOE (R/kWh )
Generic 100kW Hydro	R15,000,000.00	R86,605.57	R12,990,835.42	R27,990,835.42	12.15
Other	R0.00	R86,605.57	R0.00	R86,605.57	
System	R15,000,000.00	R0.00	R13,077,440.99	R28,077,440.99	



*Fig 4.9 Total cost of hydropower micro grid system configuration*

### 4.3 Hydro/diesel generator system configuration

Fig 4.10 shows the system configuration for Hydro/diesel generator for the supply of energy to Ha Lehloara.



*Fig 4.10 System configuration for hydro/diesel generator*

#### 4.3.1 Diesel generator

The Kohler 48RCLB - 48 kW Emergency Standby Power Diesel Generator (120/240V Single-Phase) is chosen for this study because of its low cost compared to other models. The purchase cost is USD \$8,789.00 [98], which is equivalent to R131,835 in South African currency. Both shipments and installation costs from abroad could add an extra cost of 30% of initial cost. Therefore, the total capital cost will be  $R131,835 \times 1.30 = R171,385.50$ . Replacement cost will be R160 000.00. Since the diesel generator requires more maintenance and assuming the generator will be used 60% of the total hours in a year,  $(8760 \times 0.6 = 5256 \text{ hours})$ , the O/M cost will be  $(R171,385.50/5256 \times 11.38\% = R3.799)$  about R3.80 per hour.

The datasheet that shows parameters of Kohler 48RCLB - 48 kW Generator [98] is shown in Table 4.7 below.

**Table 4.7** Datasheet of Kohler 48RCLB - 48 kW

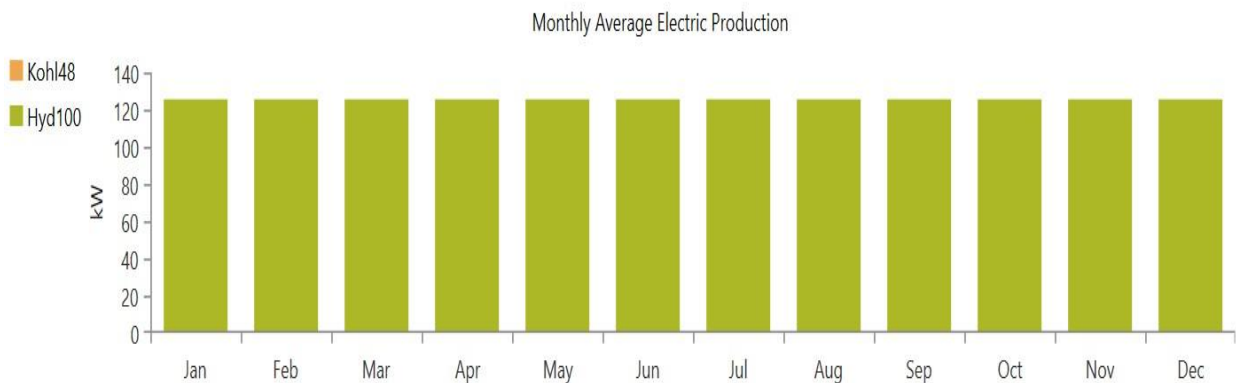
<b>Voltage</b>	120/240 single phase
<b>Frequency</b>	60 Hertz
<b>Power</b>	48 000 W
<b>Fuel</b>	Diesel
<b>Rated amps</b>	200 A
<b>Fuel @ 50% consumption</b>	4.9 gallons/hr
<b>Fuel @ 100% consumption</b>	9.3 gallons/hr
<b>Decibel rating</b>	57 test (61 run) dbA
<b>Cooling</b>	Liquid cooled

**Fig 4.11** below shows the optimisation results from HOMER software for the given system configuration whose cost of energy whose cost is R12.19 / kWh.

Architecture					Cost				System
	Koh148 (kW)	Hyd100 (kW)	Efficiency1	Dispatch	COE (R)	NPC (R)	Operating cost (R/yr)	Initial capital (R)	Ren Frac (%)
	48.0	98.1	0	LF	R12.19	R28.2M	R750,748	R15.2M	100
	48.0	98.1	1.00	LF	R12.19	R28.2M	R750,748	R15.2M	100
	48.0	98.1	1.00	CC	R12.19	R28.2M	R750,748	R15.2M	100
	48.0	98.1	0	CC	R12.19	R28.2M	R750,748	R15.2M	100

**Fig 4.11** Micro Hydro/diesel generator simulations

**Fig 4.12** below shows the monthly average electricity production in which the Hydro component of the hybrid, is the only one supplying energy while the generator is not used.

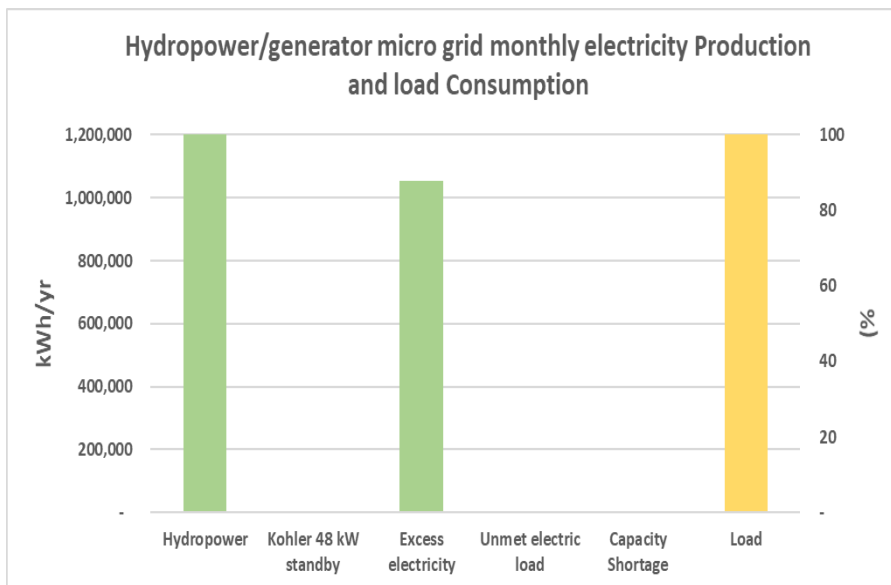


**Fig 4.12** Hydropower/Generator micro monthly electricity Production

**Table 4.8** and **Fig 4.13** below show Hydropower/generator micro grid average monthly electricity Consumption in which only hydro component supplies energy to the load. Although standby generator (Kohler 48 kW) is part of hybrid micro grid, it is not being used because the village’s peak load is 67.30 kW and Hybrid power of 98.1 kW meets this demand. That is 100% of the load is supplied by hydro component only.

**Table 4.8** Hydropower/generator micro grid monthly electricity Consumption

	kWh/yr	%
Hydropower	1,095,679	100
Kohler 48 kW standby	-	-
Excess electricity	962,206	88
Unmet electric load	-	-
Capacity Shortage	-	-
Load	133,470	100

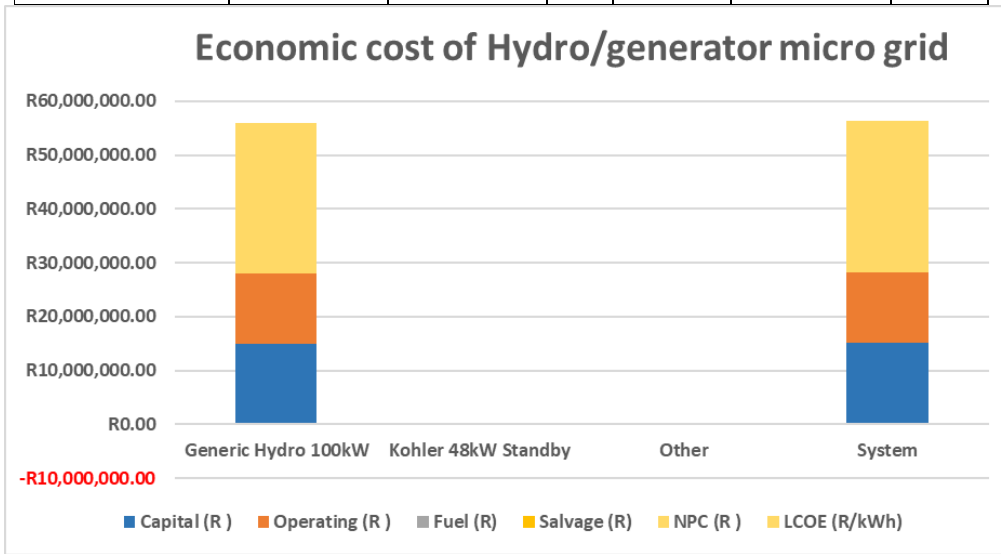


**Fig 4.13** Hydropower/generator micro grid monthly electricity consumption

**Table 4.9** and **Fig 4.14** below show the cost for hydropower/generator micro grid system, of which the total cost is R28 175 176.02 and LCOE of R12.19/kWh. Since hydro is able to supply all the demand, the fuel cost of the generator is zero (R0.00).

**Table 4.9** Micro hydropower and generator total cost

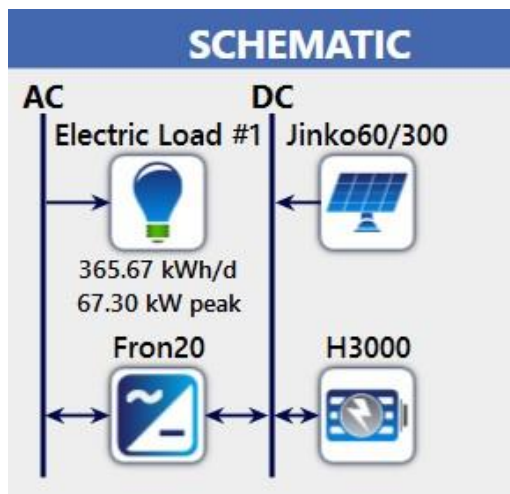
System Configuration	Capital (R )	Operating (R )	Fuel (R)	Salvage (R)	NPC (R )	LCOE (R/kWh)
Generic Hydro 100kW	R15,000,000.00	R12,990,835.42	R0.00	R0.00	R27,990,835.42	12.19
Kohler Standby 48kW	R171,385.50	R0.00	R0.00	-R73,650.48	R97,735.02	
Other	R0.00	R86,605.57	R0.00	R0.00	R86,605.57	
System	R15,171,385.50	R13,077,440.99	R0.00	-R73,650.48	R28,175,176.02	



**Fig 4.14** Micro Hydro/diesel generator total cost

#### 4.4 Solar micro grid

**Fig 4.15** below shows the system configuration for Solar for the supply of energy to Ha Lehloara.



### Fig 4.15 Solar system configuration

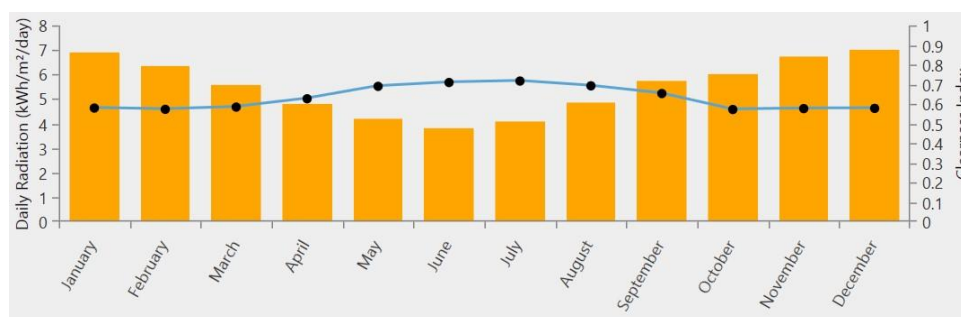
The results from the technical model of this system, for each technical component are considered below.

#### 4.4.1 Solar irradiance

Solar radiation and its clearness index for Ha Lehloara has been shown in **Table 4.10** and **Fig 4.16** below.

**Table 4.10** Daily Solar radiation and clearness index

Month	Clearness Index	Daily radiation (KWh/m <sup>2</sup> /day)
January	0.579	6.9
February	0.572	6.32
March	0.584	5.57
April	0.626	4.81
May	0.69	4.21
June	0.709	3.8
July	0.717	4.07
August	0.692	4.83
September	0.653	5.73
October	0.571	5.99
November	0.576	6.71
December	0.577	7

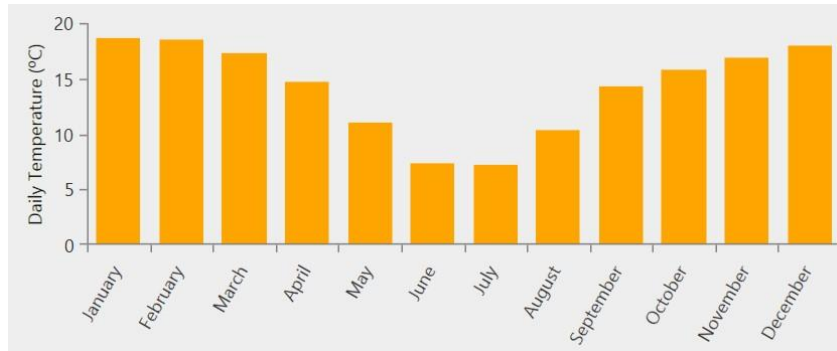


**Fig 4.16** Solar radiation and its clearness index

An average solar radiation of 5.50 kWh/m<sup>2</sup>/day and a clearness index of 0.629 were identified for this village.

#### 4.4.2 Temperature

**Fig 4.17** below shows average monthly temperature of Ha Lehloara, which begins to drop significantly from April and get to the lowest point around June and July.

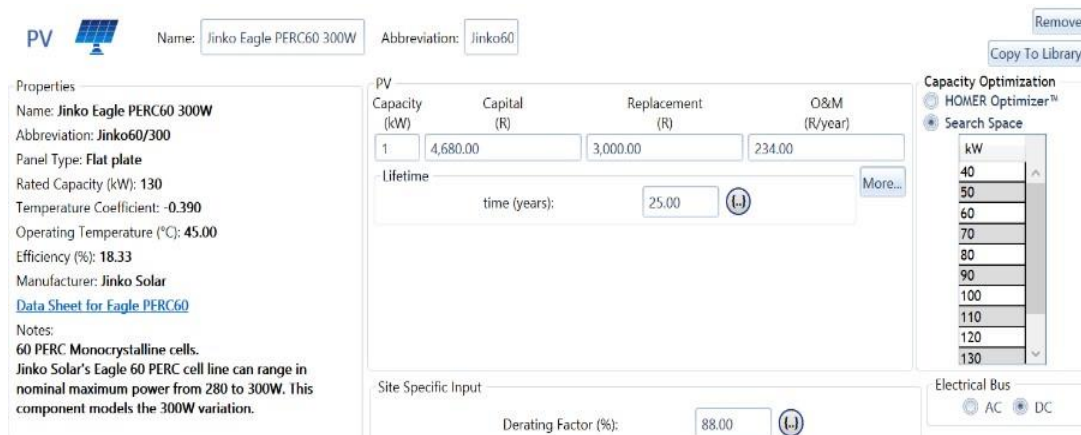


**Fig 4.17** Average monthly temperature of Ha Lehloara

### 4.4.3 Results of Solar micro grid

#### (a) PV module

The solar panel that is chosen for this load profile is Jinko Eagle PERC60 300W which has the sale price of \$0.20/ W or \$200/kW [99] (R3000/kW in South African). The shipment costs from abroad could add an extra cost of 30% of initial cost and installation could be an additional cost, which will be 20% of initial cost. Therefore, the total capital cost will be  $(R3000 \times 1.30 \times 1.20) = R4680$ . The replacement cost will be R3000, taking into consideration that costs of PV module reduced as low as USD \$0.21/W in December 2019 and in South Africa PV costs reduced by 29% between 2013 and 2019 [100]. The operating cost is calculated as 5% of the capital cost, and will be  $5\% \times R4680 = R234$ . After capturing costs for this PV module, it is important to enter the values for search space in HOMER Pro in order to come up with energy for the PV array size that will be needed to supply the 365.77 kWh daily load. **Fig 4.18** shows the search space of Jinko Eagle PERC60 300W PV array, which shows control parameters of the following values: rated power of 130 kW, efficiency of 18.33% and life time of 25 years.



**Fig 4.18** Jinko Eagle PERC60 300W PV search space

The datasheet that shows parameters of Jinko Eagle PERC60 300W is shown in **Table 4.11** [101] below. The parameters are at *Standard Test Conditions (STC): air mass AM 1.5, irradiance of 1000 W/m<sup>2</sup>, cell temperature of 25°C and Nominal Operating Cell Temperature (NOCT): 800 W/m<sup>2</sup>, AM 1.5, wind speed of 1 m/s, ambient temperature of 20°C.*

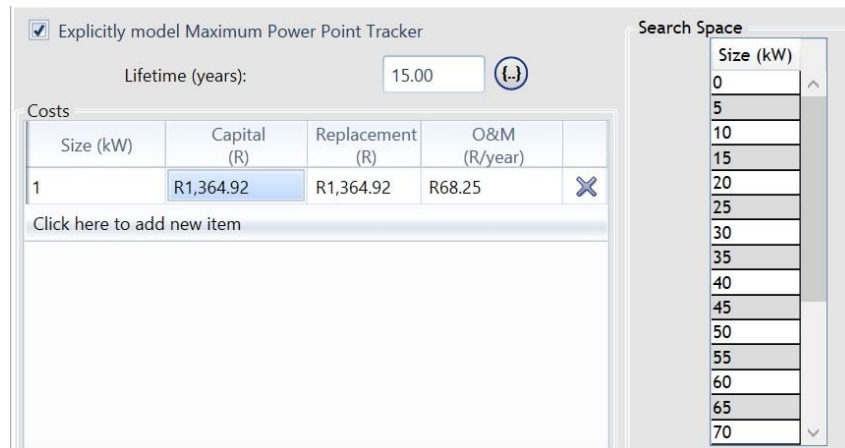
**Table 4.11** Datasheet of Jinko Eagle PERC60 300W

Model No.	JKM300M-60	
Parameter	Electrical Data at STC	Electrical Data at NOCT
Maximum Power (Pmax)	300 Wp	224 Wp
Voltage at Maximum Power (Vmpp)	32.6 V	30.6 V
Current at Maximum Power (Impp)	9.21 A	7.32 A
Open Circuit Voltage (Voc)	40.1 V	37 V
Short Circuit Current (Isc)	9.72 A	8.01 A
Panel Efficiency	18.33 %	
Power Tolerance (Positive)	+ 3 %	
Temperature		45±2 °C
Thermal Ratings		
Operating Temperature Range	-40~85 °C	
Temperature Coefficient of Pmax	-0.39 %/°C	
Temperature Coefficient of Voc	-0.29 %/°C	
Temperature Coefficient of Isc	0.05 %/°C	
Maximum System Voltage	1000 V	
Series Fuse Rating	15 A	

### (b) Charge Controller

High Quality MPPT Charge [102] controller for off grid for this study is shown in Table 4.12 below. Maximum Power Point Tracker (MPPT) Charge Controller Hybrid Solar Inverter Off Grid at a sale price of USD \$175 per unit is chosen. The system capture cost/ kW = USD \$175/3 = 58.33/kW. Therefore, assuming shipments costs for 30% and installation costs of 20%, the capital cost of charge controller of per kW will be 58.33 x 1.30 x 1.20= USD \$90.99. Converting into South African rand (USD \$1 = R 15), the capital cost becomes = 90.99 x 15 = R 1364.92.

The replacement cost will be R1364.92, while maintenance and operation cost will be 5% of capital cost and will result in  $5\% \times 1364.92 = R68.25$ . After capturing costs of Charge controller, it is important to enter the values for search space in HOMER Pro in order to come up with energy for the MMPT size that will be needed to control battery charge of 365.77 kWh daily load. **Fig 4.19** shows the search space of Charge Controller.



**Fig 4.19** Charge Controller search space

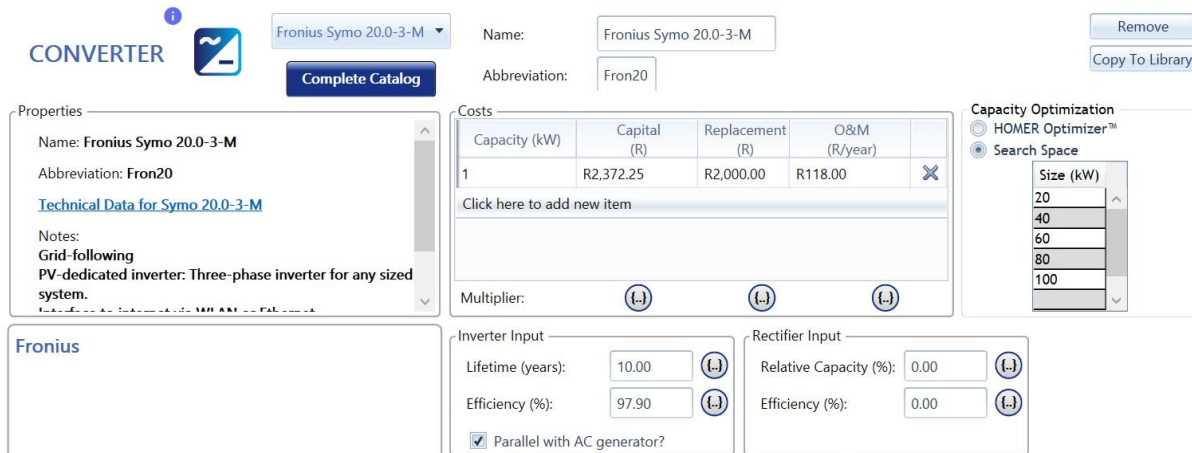
**Table 4.12** Datasheet of High Quality MPPT Charge [102] controller for off grid

<b>Model No.</b>	WRM20+ Charge Controller
<b>Parameter</b>	12 v Nominal Battery Voltage
<b>Battery voltage</b>	17.0 V
<b>Maximum PV open circuit voltage</b>	100 V
<b>Maximum PV Current</b>	19 A
<b>Maximum PV Power</b>	310 W
<b>Battery charge current</b>	20 A
<b>Load output current</b>	20 A
<b>Operating temperature (Positive)</b>	50° C

### (c) Converter

The chosen inverter is **Fronius Symo 20.0-3-M** is of rating 20 kW. The chosen inverter is of rating 20 kW and the system will need at least four of these inverters. The **Fronius Symo 20.03-M** with some input parameters shown in **Fig 4.20** below is chosen for this study and its sale price is of USD \$118.62/ kW [103] (or R2372.73/kW in South African currency). The shipment costs from abroad and installation costs could be an additional cost of 20% of initial cost.

Therefore, the total capital cost will be  $R2372.73 \times 1.20 = R2847.28$ . Replacement cost will be R2000 taking into consideration that costs of PV module reduced by (as low as) USD \$0.21/W in December 2019 and in South Africa PV costs reduced by 29% between 2013 and 2019 [100]. The Operating cost is calculated as 5% of the Capital cost, which is  $5\% \times R 2847.28 = R142.36$ .



**Fig 4.20** Fronius Symo 20.0-3-M search space

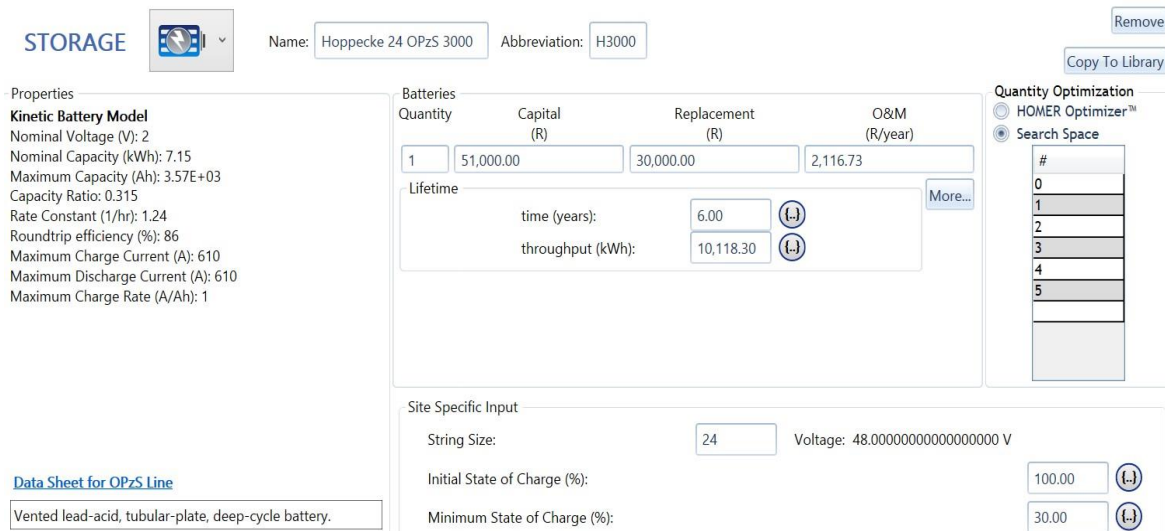
Datasheet that shows parameters of Fronius Symo 20.0-3-M [104] is shown in **Table 4.13** below. The Datasheet shows the parameters for both DC and AC data values.

**Table 4.13** Datasheet of Fronius Symo 20.0-3-M

Parameter	DC data values	AC data values
Max. input current ( $I_{dc \max 1} / I_{dc \max 2}$ )	33.0 A/27.0 A	
AC nominal output ( $P_{ac,r}$ )		20 000 W
Max-array short circuit current (MPP1/MPP2)	49.5 A/40.5 A	
Max. output power		20 000 VA
Min. input voltage ( $U_{dc \min}$ )	200 V	
AC output current ( $I_{ac \text{ nom}}$ )		28.9 A
Feed-in start voltage ( $U_{dc \text{ start}}$ )	200 V	
Nominal input voltage ( $U_{dc,r}$ )	600 V	
Max. input voltage ( $U_{dc \max}$ )	1,000 V	
MPP voltage range ( $U_{mpp \min} - U_{mpp \max}$ )	420 – 800 V	
DC start voltage feed-in (V)	30.0 kW <sub>peak</sub>	
Max. Efficiency		98.1%

**(d) Battery**

The suitable battery for this system is Hoppecke 24 OPzS 3000 which has nominal capacity of 7.15 kWh and nominal voltage of 2V. The Power from this battery will be  $7.25/2 = 3.575$  kWh or 3 575 Ah. The total batteries for this battery bank will be  $731.54/7.15 = 103$  Batteries. Since each string size capacity is 48 V, the number of batteries in each string will be  $48V/2V=24$  batteries. Since the total batteries needed for this system is 103, there will be  $103/24= 5$  strings of 48 V each. The purchase cost is US \$ Hoppecke 24 OPzS 3000 [105]. Therefore, assuming shipments costs and installation costs of 30%, the capital cost of charge controller of per kW will be  $2171 \times 1.30 \times 1.30 = \text{USD } \$ 2 822.30$  or R 42 334.50. The replacement cost will be R 30 000.00, while maintenance and Operation cost will be 5% of capital cost and will result in  $8\% \times 42 334.50 = \text{R } 3 386.76$ . **Fig 4.21** shows the search space of Battery bank.



**Fig 4.21** Search space of Hoppecke 24 OPzS 3000

The Datasheet that shows the values of the parameters of the battery, *Hoppecke 24 OPzS 3000* [106], is shown in **Table 4.14** below.

**Table 4.14** Datasheet of Hoppecke 24 OPzS 3000

Parameter	Value
Nominal voltage	2V
Rated capacity	3000 Ah
Nominal Capacity(kwh)	7.15
Efficiency(%)	86
Maximum charge current	610
Maximum discharge current (A)	610
Maximum charge rate (A/ah)	1
Charge	Initial charging 750 A and Voltage 2.33 – 2.38 V

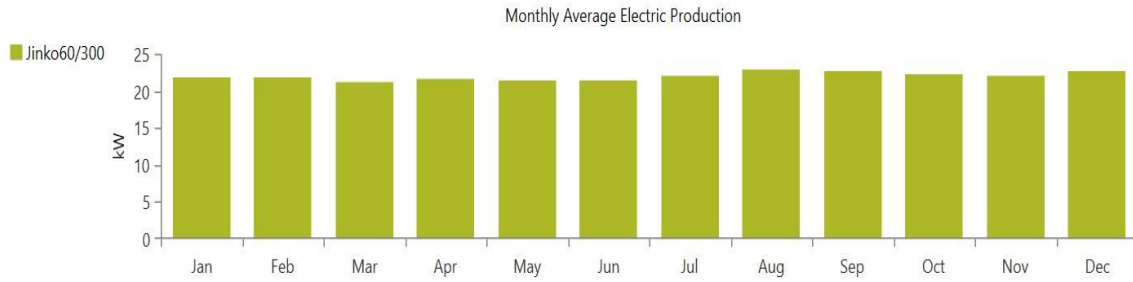
(e) **Overall System**

**Fig 4.22** below shows the optimisation results from HOMER software. The solar micro grid produces over 145 kW of energy whose lowest cost is R4.64/kWh.

Architecture								Cost				System
Jinko60/300 (kW)	Jinko60/300-MPPT (kW)	H3000	Fron20 (kW)	Efficiency1	Dispatch	COE (R)	NPC (R)	Operating cost (R/yr)	Initial capital (R)	Ren Frac (%)		
145	60.0	48	40.0	0	LF	R4.64	R10.4M	R410,341	R3.30M	100		
145	60.0	48	40.0	1.00	CC	R4.64	R10.4M	R410,341	R3.30M	100		
145	60.0	48	40.0	1.00	LF	R4.64	R10.4M	R410,341	R3.30M	100		
145	60.0	48	40.0	0	CC	R4.64	R10.4M	R410,341	R3.30M	100		
150	55.0	48	40.0	1.00	LF	R4.64	R10.4M	R409,753	R3.32M	100		

**Fig 4.22** Solar microgrid simulations

**Fig 4.23** below shows the uniform monthly average electricity production from solar in order to supply the village load of 365.67 kW/day. This shows that the daily production is able to meet 100% of the daily demand of the village.

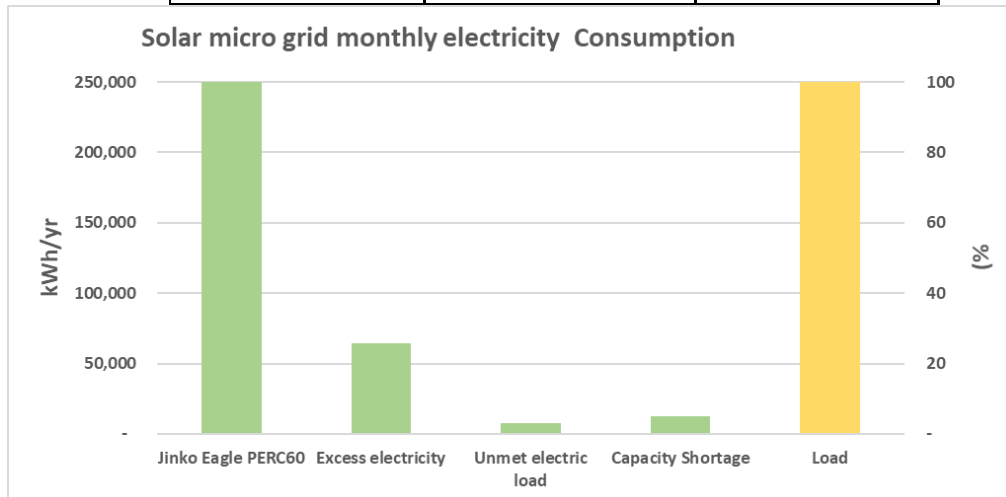


**Fig 4.23** Solar micro monthly electricity Production

**Table 4.15** and **Fig 4.24** below show Solar micro grid’s average monthly electricity Consumption which produces excess electricity of 49 734 kwh/yr. The annual capacity shortage of 6732 kwh is realised because the micro grid’s actual operating capacity is below the required operating capacity in some days. Hence there is annual unmet electricity load of 4071 kwh.

**Table 4.15** Solar micro monthly electricity Consumption

	kWh/yr	%
Jinko Eagle PERC60	192,659	100
Excess electricity	49,734	26
Unmet electric load	4,071	3
Capacity Shortage	6,732	5
Load	129,399	100



**Fig 4.24** Solar electricity monthly Consumption

**Table 4.16** and **Fig 4.25** below shows the cost of the Solar micro grid system. The total cost of this systems is R10 405 557.55, with the LCOE of R4.64/kWh.

**Table 4.16** Solar total cost

System Configuration	Capital (R)	Operating (R)	Fuel (R)	Salvage (R)	NPC (R)	LCOE (R/kWh)
Fronius Symo 20.0-3-M	R94,890.00	R103,139.48	R81,755.66	-R18,884.74	R260,900.40	4.64
Hoppecke 24 OPzS 3000	R2,448,000.00	R3,746,447.91	R3,392,166.95	-R566,542.12	R9,020,072.74	
Jinko Eagle PERC60 300W	R678,600.00	R0.00	R113,648.16	R0.00	R792,248.16	
Jinko60/300 Dedicated Converter	R76,500.00	R48,763.18	R132,506.52	-R12,039.02	R245,730.68	
Other	R0.00	R0.00	R86,605.57	R0.00	R86,605.57	
System	R3,297,990.00	R3,898,350.58	R3,806,682.85	-R597,465.88	R10,405,557.55	

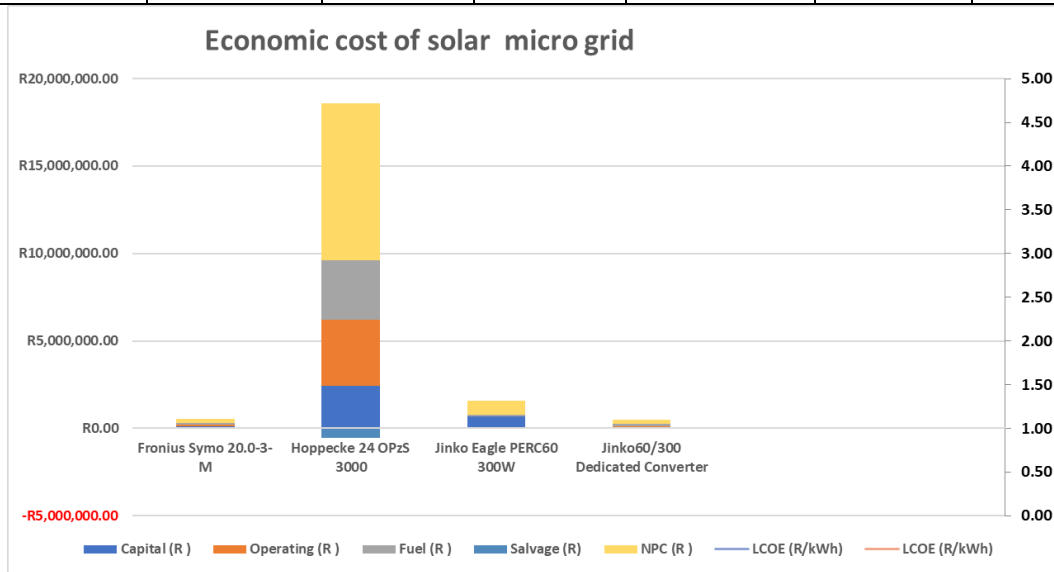


Fig 4.25 Cost of Solar configuration

Fig 4.26 below shows the sensitivity analysis of Solar micro grid system.

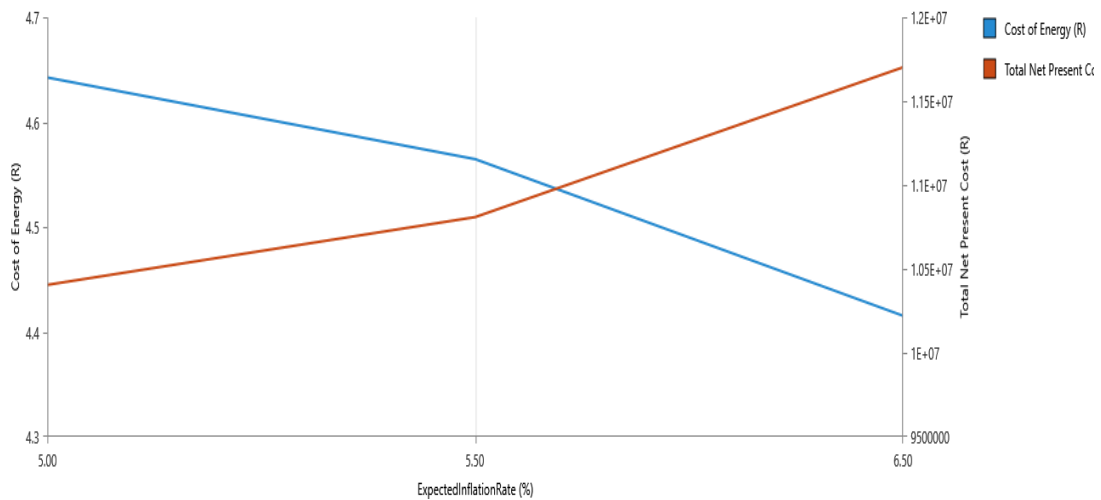


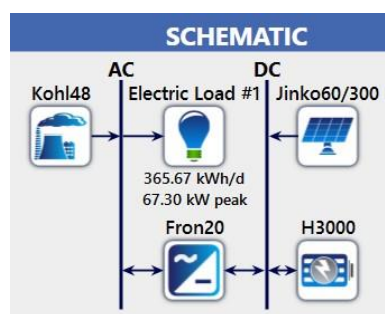
Fig 4.26 Sensitivity analysis results

From **Fig 4.26** above, as inflation rate increases from 5.00 % to 6.50 %, NPC increases from R10.4 million to R11.7 million as a result the COE decreases from R4.64/kWh to R4.42/kWh. This is because, as inflation increases at the same nominal discount rate, the real discount rate decreases. A decrease of the COE from a higher value of R4.64/kWh (USD \$0.309/kWh) to a lower value of R4.42/kWh (USD \$0.295/kWh), means the cost of energy is becoming cheaper for the consumer. This means this option of *Solar configuration* is economically viable compared to the LCOE of R5.00/kWh (USD \$0.344/kWh) by One Power, which runs the Solar PV/generator hybrid mini-grid for the rural village of Ha Makebe [107]. In summary, although the Solar bank system configuration is economically viable, it is not technically viable.

Therefore, it cannot be chosen for implementation.

#### 4.5 Solar/Generator system configuration

**Fig 4.27** shows the system configuration for Solar/Generator for the supply of energy to Ha Lehloara.



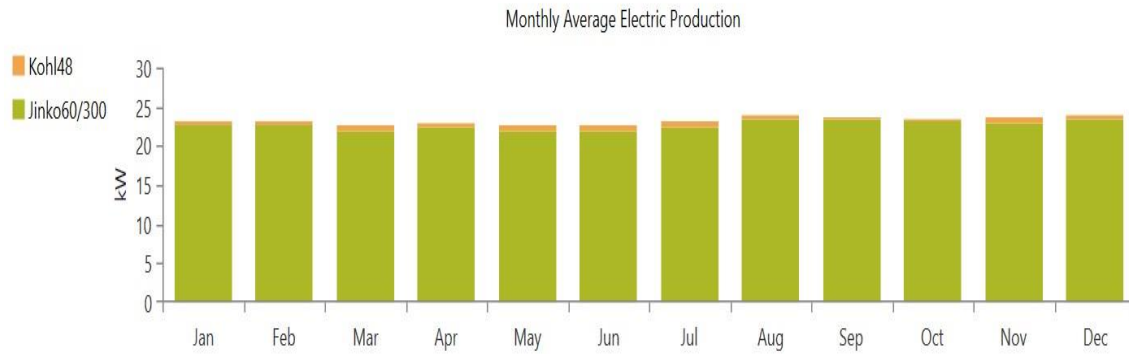
**Fig 4.27** Solar/Generator system configuration

**Fig 4.28** below shows the optimisation results from HOMER software. The solar micro grid gives out 160 kW power while generator gives out 48 kW.

Optimization Results														
Architecture										Cost				System
Jinko60/300 (kW)	Jinko60/300-MPPT (kW)	Kohl48 (kW)	H3000	Fron20 (kW)	Efficiency1	Dispatch	COE (R)	NPC (R)	Operating cost (R/yr)	Initial capital (R)	Ren. Frac (%)			
160	60.0	48.0	48	45.0	0	LF	R4.80	R11.1M	R436,039	R3.55M	96.3			
160	60.0	48.0	48	45.0	1.00	LF	R4.80	R11.1M	R436,039	R3.55M	96.3			
165	60.0	48.0	48	45.0	1.00	LF	R4.80	R11.1M	R434,747	R3.57M	96.5			
165	60.0	48.0	48	45.0	0	LF	R4.80	R11.1M	R434,747	R3.57M	96.5			
170	60.0	48.0	48	45.0	1.00	LF	R4.80	R11.1M	R433,549	R3.60M	96.6			

**Fig 4.28** Solar/Generator system simulations

**Fig 4.29** below shows the monthly average electricity production which shows over 98% of power comes from solar while about 2% comes from generator.

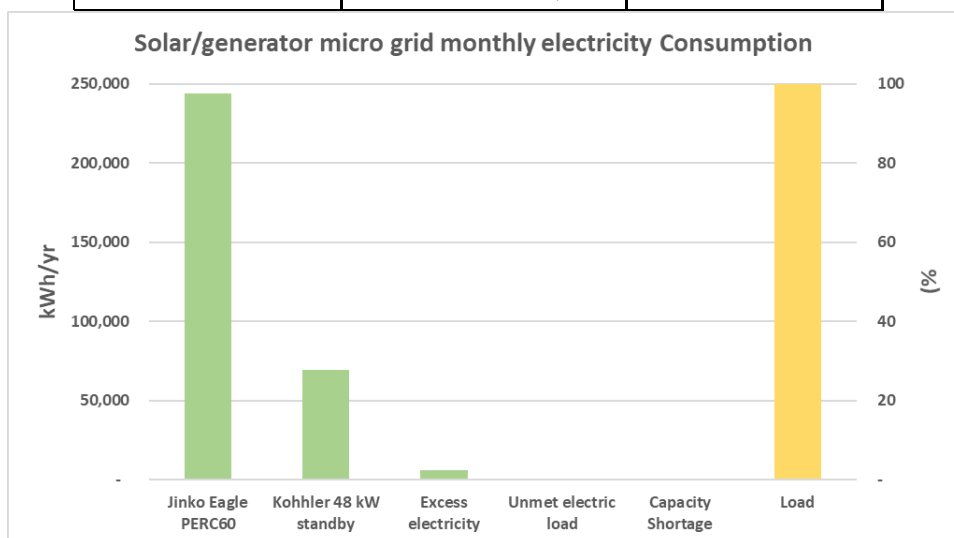


**Fig 4.29** Solar/Generator micro monthly electricity Production

**Table 4.17** and **Fig 4.30** below shows Solar/Generator micro average monthly electricity Consumption in which annual power produced is able to address the daily load demand of 365.67 kWh/day.

**Table 4.17** Solar/Generator micro monthly electricity Consumption

	kWh/yr	%
Jinko Eagle PERC60	198,473	97.50
Kohhler 48 kW standby	4,996	2.46
Excess electricity	56,508	27.80
Unmet electric load	-	-
Capacity Shortage	-	-
<b>Load</b>	<b>133,470</b>	<b>100</b>



**Fig 4.30** Solar/Generator monthly production and consumption

The renewable energy fraction is 97.5% while non-renewable energy from diesel generator is 2.46% which give out carbon emissions as a result of burning 1851 Litres of diesel as shown in **Fig 4.31** below per year.

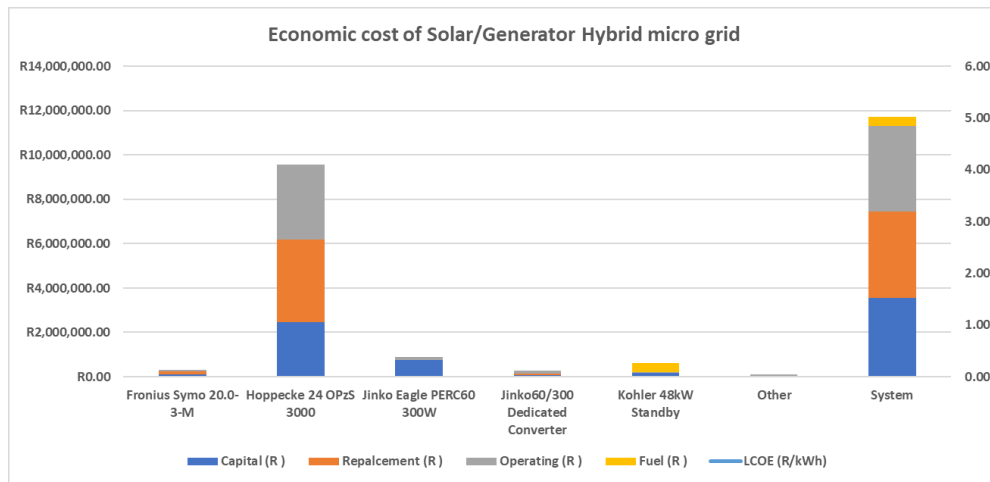


**Fig 4.31 Diesel Generator Emissions**

**Table 4.18** and **Fig 4.32** below show the cost of the Solar/Generator micro grid system. The total cost of this systems is R11 104 119.37 with the LCOE of R4.80/kWh.

**Table 4.18 Solar/Generator total cost**

System Configuration	Capital (R )	Repalcement (R )	Operating (R )	Fuel (R )	Salvage (R )	NPC (R )	LCOE (R/kWh)	Payback Period (yrs)	IRR (%)	ROI (%)	NPV (R )
Fronius Symo 20.0-3-M	R106,751.25	R116,031.92	R91,975.11	R0.00	-R21,245.33	R293,512.95	4.80	5.81	18.0	15.5	940,994.00
Hoppecke 24 OPzS 3000	R2,448,000.00	R3,746,447.91	R3,392,166.95	R0.00	-R566,542.12	R9,020,072.74					
Jinko Eagle PERC6 0 300W	R748,800.00	R0.00	R125,404.86	R0.00	R0.00	R874,204.86					
Jinko60/300 Dedicat ed Converter	R76,500.00	R48,763.18	R132,506.52	R0.00	-R12,039.02	R245,730.68					
Kohler 48kW Standby	R171,385.50	R0.00	R24,676.35	R415,124.73	-R27,194.02	R583,992.56					
Other	R0.00	R0.00	R86,605.57	R0.00	R0.00	R86,605.57					
System	R3,551,436.75	R3,911,243.01	R3,853,335.37	R415,124.73	-R627,020.49	R11,104,119.37					



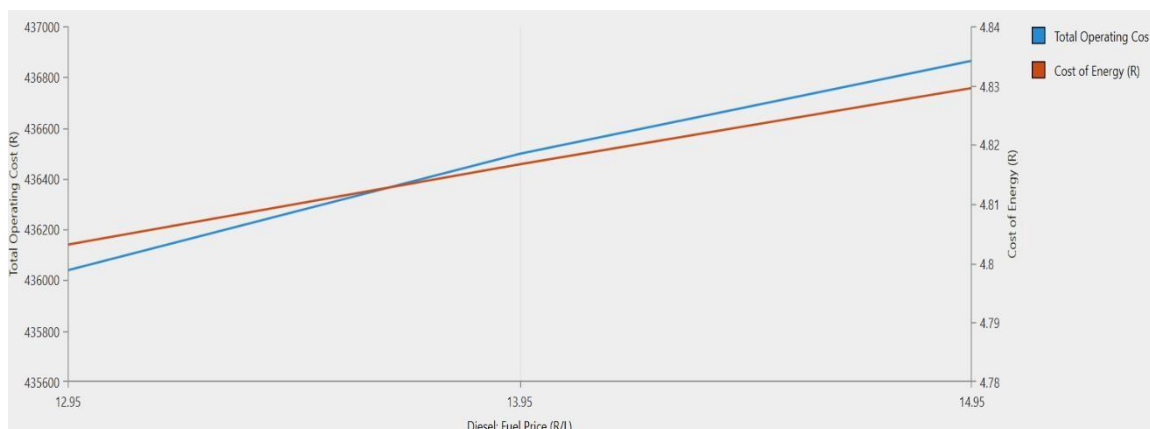
**Fig 4.32 Solar/Generator system Cost**

### 4.5.1 NPV, IRR and Payback Period

Net Present Value (NPV) of this system is R940 994.00 which shows that this project is viable to the investor because NPV is greater than zero ( $NPV > 0$ ). The internal rate of return is 18.0%, which is greater than the discount rate of 8.02 %, shows the loss from this project. The Return on Investment is 15.5%, which means this project is profitable. The internal rate of return is 18.0%, which will be good depending on the interest rate from the project. The payback period of the loan is 5.81 years if this project is financed by debt from borrowers.

### 4.5.2 Sensitivity Analysis Results of Solar/Generator micro grid system

The Solar/Generator micro grid system is sensitive to changes in the price of diesel for the generator. Sensitivity analysis results are shown in Fig 4.33 below.



**Fig 4.33 Sensitivity analysis results graph**

As diesel price increases from R13.00/litre to R14.00/litre and R15.00/litre, Operating Cost/yr increases from R436 039 to R436 498 and R436 864 respectively. As a result, the COE increase

from R4.80/kWh to R4.82/kWh and to R 4.83/kWh respectively. An increase of the COE from a higher value of R4.80/kWh (USD \$0.32/kWh) to R4.83/kWh (USD \$0.32/kWh) means the cost of energy is becoming expensive for the consumer.

## 4.6 Wind micro grid

### 4.6.1 Wind speed

The wind speed results after extrapolation at Ha Lehloara have been shown below, in **Table 4.19** and **Fig 4.34** respectively.

**Table 4.19** Extrapolated wind speeds of Ha Lehloara village

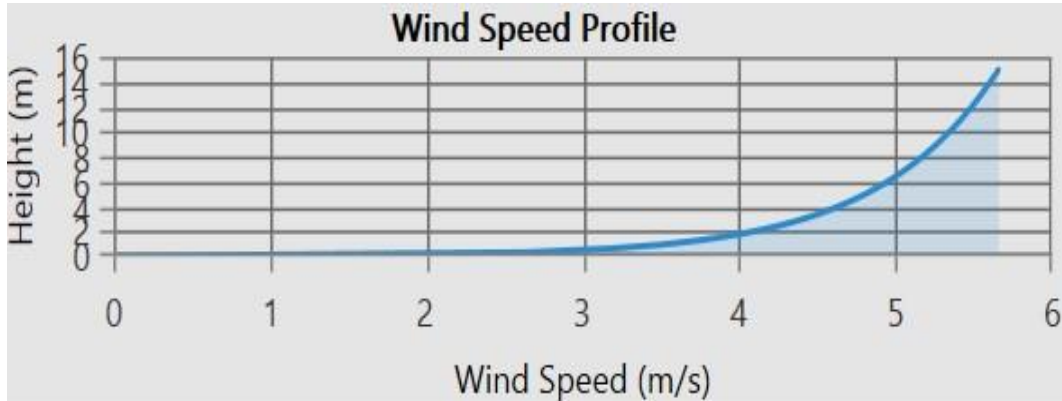
Month	Wind Speed @ anemometer height	Hub height	Anemometer height	Roughness height	Numerator	Denominator	LN - F	LN - G	Wind speed @hub height
January	4.13	40	10	0.01	4000	1000	8.29405	6.907755	4.96
February	3.84	40	10	0.01	4000	1000	8.29405	6.907755	4.61
March	3.9	40	10	0.01	4000	1000	8.29405	6.907755	4.68
April	3.96	40	10	0.01	4000	1000	8.29405	6.907755	4.75
May	4.17	40	10	0.01	4000	1000	8.29405	6.907755	5.01
June	4.61	40	10	0.01	4000	1000	8.29405	6.907755	5.54
July	4.71	40	10	0.01	4000	1000	8.29405	6.907755	5.66
August	5.11	40	10	0.01	4000	1000	8.29405	6.907755	6.14
September	5.33	40	10	0.01	4000	1000	8.29405	6.907755	6.40
October	4.98	40	10	0.01	4000	1000	8.29405	6.907755	5.98
November	4.47	40	10	0.01	4000	1000	8.29405	6.907755	5.37
December	4.21	40	10	0.01	4000	1000	8.29405	6.907755	5.05
								<b>Average</b>	<b>5.35</b>

The average wind speed is 5.35 m/s. Since Ha Lehloara village is in the mountains of Lesotho, the roughness will be taken as 0.01.



**Fig 4.34** Wind speed at Ha Lehloara

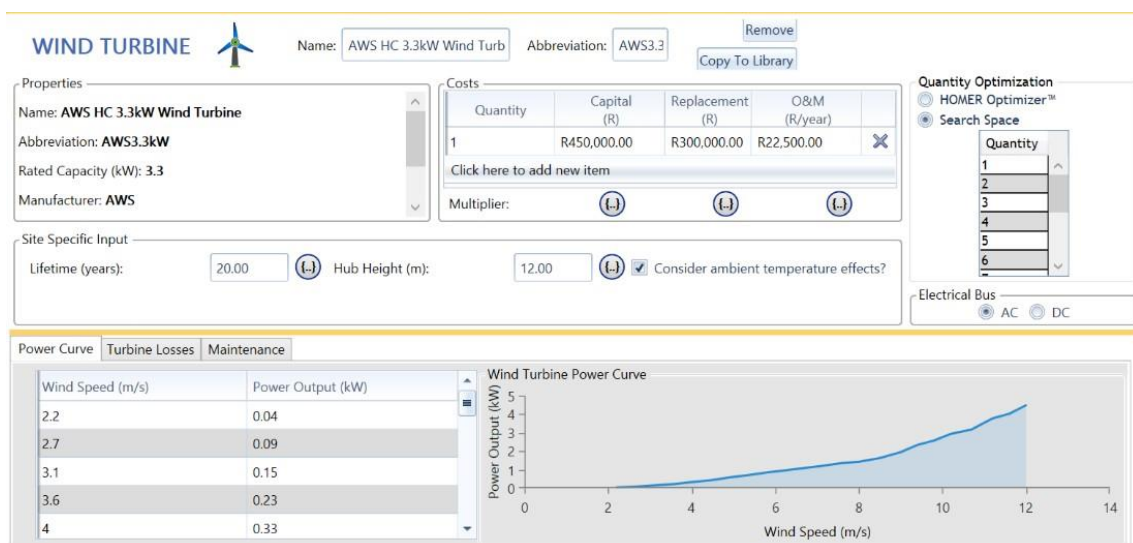
**Fig 4.35** below shows the wind profile curve from HOMER for the above extrapolated wind speeds at an average wind speed of 5.35 m/s.



**Fig 4.35** Wind profile at Ha Lehloara

#### 4.6.2 Wind turbine

The AWS HC 3.3kW wind turbine is chosen for this system. The purchase cost is USD \$25,000 [108], (or R375000). The shipment and installation costs could amount to 15% of the initial cost. Therefore, the total capital cost will be  $375000 \times 1.20 = R450000$ . Maintenance and Operation cost is calculated at 5% of the capital cost. Thus, Maintenance cost will be  $5\% \times R450000 = R22500$ . **Fig 4.36** below shows some input values and wind power generation curve of wind turbine. **Table 4.20** gives an overview of Datasheet of *wind turbine* [108] used in this study.



**Fig 4.36** Search space of wind turbine

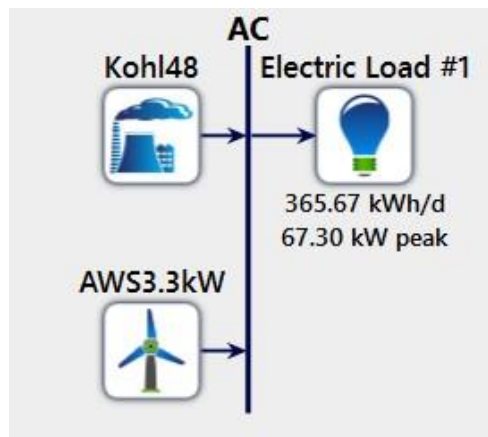
**Table 4.20** Datasheet of wind turbine

<b>Rated Output</b>	3300W
<b>Rated Wind Speed</b>	10.5m/s, 24mph
<b>Peak Output</b>	3650W
<b>Cut In</b>	2.7m/s, 6mph
<b>Generator</b>	PM 3 phase alternator (variable speed)
<b>RPM—50Hz/60Hz</b>	375 / 450
<b>Over Speed Limit</b>	525RPM / 70Hz
<b>Rotor Diameter</b>	4.65m / 15f
<b>Number of Blades</b>	3 standard (6 for extra charge)
<b>Swept Area</b>	6.4 sq.m / 175 sq.feet
<b>Min Tip Clearance</b>	36cm / 14in
<b>Operating Life</b>	20 years
<b>Survival Wind Speed</b>	55 m/s
<b>Unit Weight (Tower Top)</b>	77kg
<b>Gov. Shut down speed/opt stop</b>	Electro-dynamic Switch

<b>Govern Speed</b>	27mph
<b>Governor-Over Speed Limit</b>	Uptilt tilt (Hydraulic assisted)
<b>Lateral Thrust (max)</b>	3200nts
<b>Suggested Routine Maintenance</b>	Annual Inspection

#### 4.7 Wind/Generator system configuration

The wind turbine 3.3 kW and Kohler generator used for hydro micro grid, were both used for wind/generator micro grid system. **Fig 4.37** shows the system configuration for wind/generator for the supply of energy to Ha Lehloara.



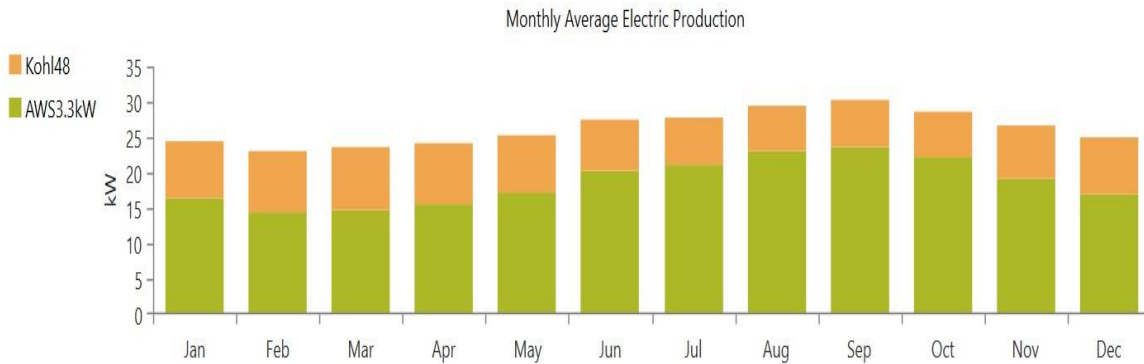
**Fig 4.37** Wind/Generator system configuration

**Fig 4.38** shows Wind/Generator system simulations results from HOMER. The wind/generator produces 30 kW from wind and 48 kW from generator.

Optimization Results													
Left Double Click on a particular system to see its detailed Simulation Results.													
Architecture					Cost				System				
	AWS3.3kW	Kohl48 (kW)	Efficiency1	Dispatch	COE (R)	NPC (R)	Operating cost (R/yr)	Initial capital (R)	Ren Frac (%)	Total Fuel (L/yr)	Hours	Production (kWh)	Fuel (L)
↑	30	48.0	1.00	CC	R14.49	R33.5M	R1.14M	R13.7M	50.4	23,600	4,416	66,145	23,600
↑	30	48.0	0	LF	R14.49	R33.5M	R1.14M	R13.7M	50.4	23,600	4,416	66,145	23,600
↑	30	48.0	1.00	LF	R14.49	R33.5M	R1.14M	R13.7M	50.4	23,600	4,416	66,145	23,600
↑	30	48.0	0	CC	R14.49	R33.5M	R1.14M	R13.7M	50.4	23,600	4,416	66,145	23,600
↑	35	48.0	0	CC	R16.19	R37.4M	R1.24M	R15.9M	54.8	21,525	4,027	60,331	21,525
↑	35	48.0	1.00	LF	R16.19	R37.4M	R1.24M	R15.9M	54.8	21,525	4,027	60,331	21,525
↑	35	48.0	0	LF	R16.19	R37.4M	R1.24M	R15.9M	54.8	21,525	4,027	60,331	21,525
↑	35	48.0	1.00	CC	R16.19	R37.4M	R1.24M	R15.9M	54.8	21,525	4,027	60,331	21,525
↑	40	48.0	1.00	LF	R17.95	R41.5M	R1.35M	R18.2M	58.1	19,947	3,731	55,914	19,947

**Fig 4.38** Wind/Generator system simulations

**Fig 4.39** below shows the electricity production from this system which shows energy supply mix from both wind and generator.

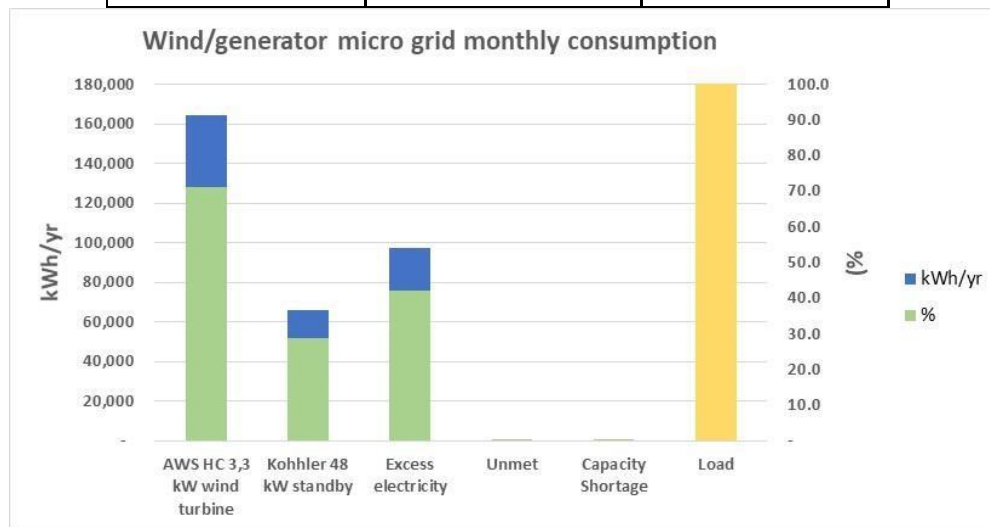


**Fig 4.39** Wind/Generator electricity production

**Table 4.21** and **Fig 4.40** below show Wind/Generator micro grid system’s average monthly electricity Consumption of 71.3% from wind and 28.7 % from generator.

**Table 4.21** Wind/generator micro grid monthly electricity Consumption

	kWh/yr	%
AWS HC 3,3 kW wind turbine	164,323	71.3
Kohhler 48 kW standby	66,145	28.7
Excess electricity	97,057	42.1
Unmet	58.5	0.0428
Capacity Shortage	58.5	0.0428
Load	133,411	100



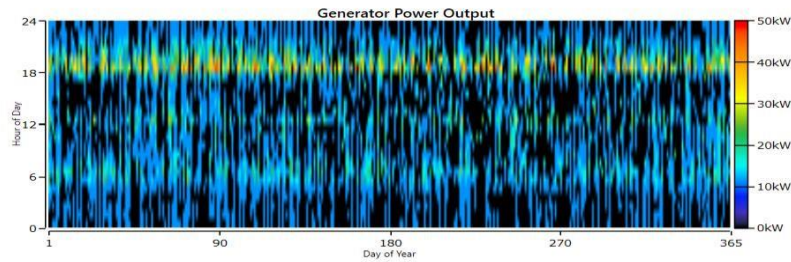
**Fig 4.40** Wind/Generator electricity consumption

**Fig 4.41** below shows that a generator operates 4 416 hours annually and burn 23600 litres of diesel as carbon emissions.

Quantity	Value	Units
Hours of Operation	4,416	hrs/yr
Number of Starts	939	starts/yr
Operational Life	3.40	yr
Capacity Factor	15.7	%
Fixed Generation Cost	31.9	R/hr
Marginal Generation Cost	3.45	R/kWh

Quantity	Value	Units
Electrical Production	66,145	kWh/yr
Mean Electrical Output	15.0	kW
Minimum Electrical Output	12.0	kW
Maximum Electrical Output	48.0	kW

Quantity	Value	Units
Fuel Consumption	23,600	L
Specific Fuel Consumption	0.357	L/kWh
Fuel Energy Input	232,227	kWh/yr
Mean Electrical Efficiency	28.5	%



**Fig 4.41** Diesel Generator fuel consumption

**Table 4.22** below shows the amount of carbon emissions which is 61,762 kg per annum, that get into the atmosphere as a result of burning 23 600 litre of diesel which causes a lot of pollution into the atmosphere.

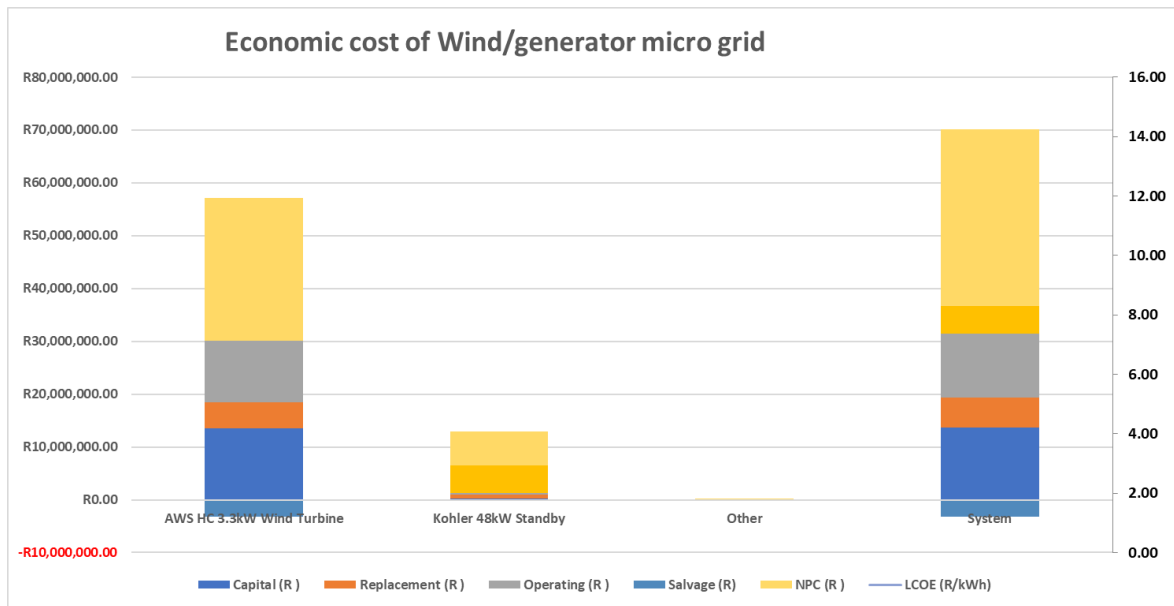
**Table 4.22** Carbon emission

Quantity	Value	Units
Carbon Dioxide	61,762	kg/yr
Carbon Monoxide	399	kg/yr
Unburned Hydrocarbons	17.0	kg/yr
Particulate Matter	2.36	kg/yr
Sulfur Dioxide	151	kg/yr
Nitrogen Oxides	370	kg/yr

**Table 4.23** and **Fig 4.42** below shows Wind/Generator system of which the total cost is R33 489 793.97, with the LCOE of R14.49/kWh.

**Table 4.23** Wind/Generator system cost

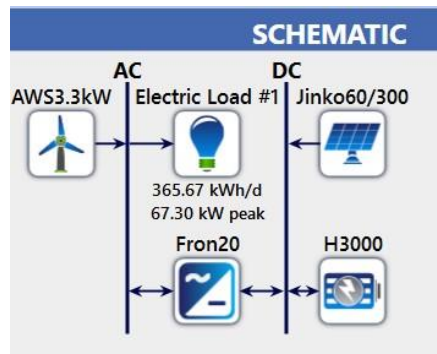
System Configuration	Capital (R)	Replacement (R)	Operating (R)	Fuel (R)	Salvage (R)	NPC (R)	LCOE (R/kWh)
AWS HC 3.3kW Wind Turbine	R13,500,000.00	R4,937,229.05	R11,691,751.88	R0.00	-R3,186,799.43	R26,942,181.50	14.49
Kohler 48kW Standby	R171,385.50	R760,440.26	R283,778.04	R5,293,748.02	-R48,344.93	R6,461,006.89	
Other	R0.00	R0.00	R86,605.57	R0.00	R0.00	R86,605.57	
System	R13,671,385.50	R5,697,669.30	R12,062,135.50	R5,293,748.02	-R3,235,144.35	R33,489,793.97	



*Fig 4.42 Wind/Generator system cost*

#### 4.8 Solar/wind system configuration

All the components that were used in solar micro grid and wind micro grid will also be used for this system configuration. **Fig 4.43** below shows the system configuration for solar PV/wind for the supply of energy to Ha Lehloara.



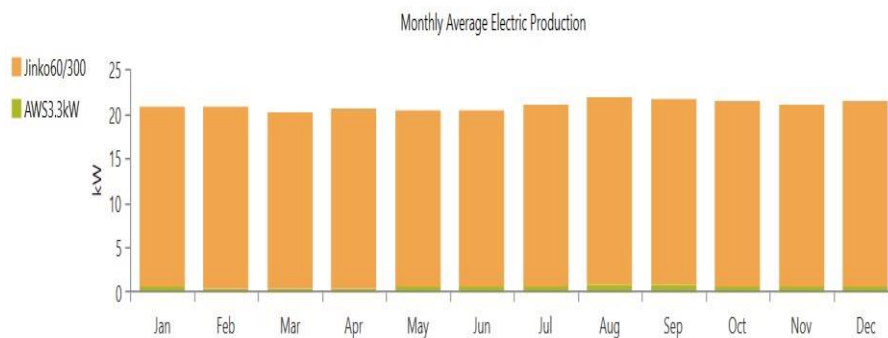
*Fig 4.43 Solar/Wind system configuration*

**Fig 4.44** below shows the optimisation results from HOMER software. Majority of power of about 135 KW supply comes from solar while wind only provides about 1 kW of energy.

	Jinko60/300 (kW)	Jinko60/300-MPPT (kW)	AWS3.3kW	H3000	Fron20 (kW)	Efficiency1	Dispatch	COE (R)	NPC (R)	Operating cost (R/yr)
	135	55.0	1	48	35.0	0	LF	R5.03	R11.2M	R433,745
	135	55.0	1	48	35.0	1.00	CC	R5.03	R11.2M	R433,745
	135	55.0	1	48	35.0	1.00	LF	R5.03	R11.2M	R433,745
	135	55.0	1	48	35.0	0	CC	R5.03	R11.2M	R433,745

**Fig 4.44** Solar/Wind system output

**Fig 4.45** below shows the monthly average electricity production in which over 94% of electricity consumption of load is provided by solar while rest is from wind.

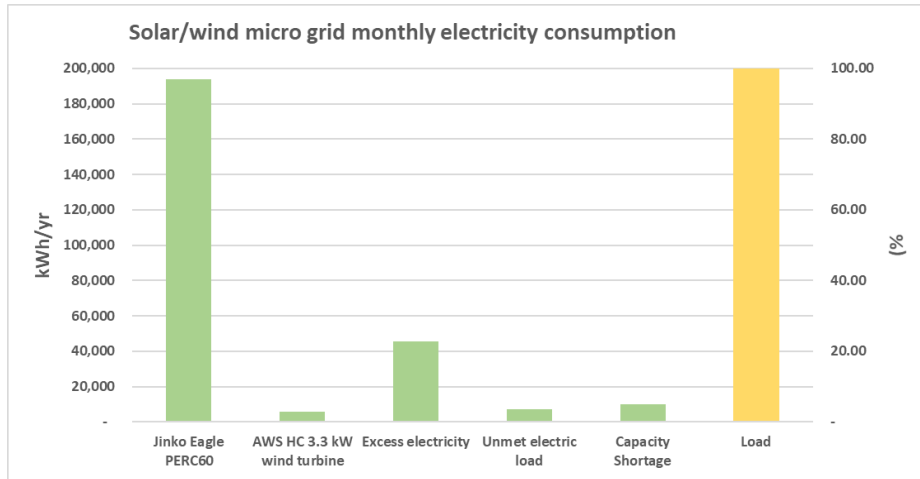


**Fig 4.45** Solar/Wind micro grid monthly electricity Production

**Table 4.24** and **Fig 4.46** below show Solar/Wind micro average monthly electricity Consumption. This micro grid is not able to supply the village all with all energy demands. There is capacity shortage of 4.96%.

**Table 4.24** Solar/Wind micro grid monthly electricity consumption

	kWh/yr	%
Hydro 30 kW	328,704	94.00
Jinko Eagle PERC60	19,254	5.53
Kohler 48 kW	132	0.0379
Excess electricity	214,248	61.50
Unmet electric load	-	-
Capacity Shortage	-	-
Load	133,470	100.00



**Fig 4.46** Solar/Wind electricity consumption

**Table 4.25** and **Fig 4.47** below show the total cost of the Solar/Wind micro grid system of which the total cost is R11 195 902.36 and LCOE of R5.03/kWh.

**Table 4.25** Solar/Wind total cost

System Configuration	Capital (R )	Replacement (R )	Operating (R )	Fuel (R )	Salvage (R)	NPC (R )	LCOE (R/kWh)
AWS HC 3.3kW Wind Turbine	R450,000.00	R164,574.30	R389,725.06	R0.00	-R106,226.65	R898,072.72	5.03
Fronius Symo 20.0-3-M	R83,028.75	R90,247.05	R71,536.20	R0.00	-R16,524.15	R228,287.85	
Hoppecke 24 OPzS 3000	R2,448,000.00	R3,746,447.91	R3,392,166.95	R0.00	-R566,542.12	R9,020,072.74	
Jinko Eagle PERC60 300W	R631,800.00	R0.00	R105,810.35	R0.00	R0.00	R737,610.35	
Jinko60/300 Dedicated Converter	R70,125.00	R44,699.58	R121,464.31	R0.00	-R11,035.77	R225,253.12	
Other	R0.00	R0.00	R86,605.57	R0.00	R0.00	R86,605.57	
System	R3,682,953.75	R4,045,968.84	R4,167,308.44	R0.00	-R700,328.68	R11,195,902.36	

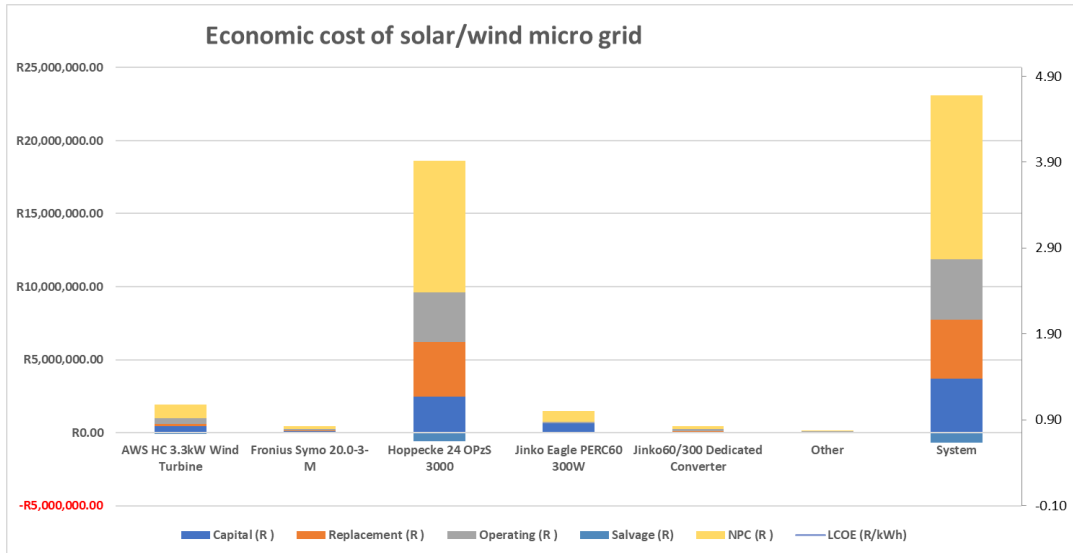


Fig 4.47 Solar/Wind system Cost

#### 4.9 Solar/Wind/Generator system configuration

All components used in solar micro grid and wind/generator micro grid will also be used for this system configuration. Fig 4.48 below shows the system configuration for Solar PV/ wind/generator microgrid system for the supply of energy to Ha Lehloara.

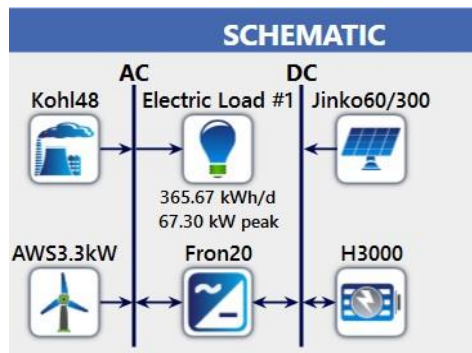


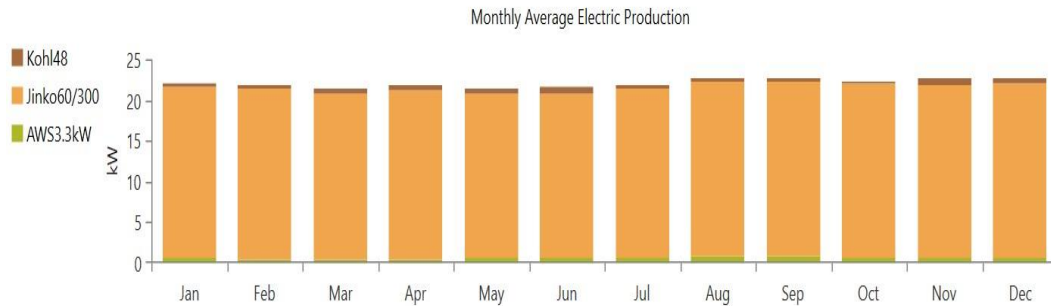
Fig 4.48 Solar/Wind/Generator microgrid system configuration

Fig 4.49 below shows Solar/Wind/Generator system simulations from HOMER. The solar micro grid produces 150 kw Power, while generator produces 48 kW and 1 kW of power comes from wind.

Optimization Results											
Left Double Click on a particular system to see its detailed Simulation Results.											
Architecture											
	Jinko60/300 (kW)	Jinko60/300-MPPT (kW)	AWS3.3kW	Kohl48 (kW)	H3000	Fron20 (kW)	Efficiency1	Dispatch	COE (R)	NPC (R)	
☰	150	55.0	1	48.0	48	45.0	1.00	LF	R5.16	R11.9M	
☰	150	55.0	1	48.0	48	45.0	0	LF	R5.16	R11.9M	
☰	145	60.0	1	48.0	48	45.0	0	LF	R5.16	R11.9M	
☰	145	60.0	1	48.0	48	45.0	1.00	LF	R5.16	R11.9M	
☰	145	55.0	1	48.0	48	45.0	0	LF	R5.16	R11.9M	

**Fig 4.49** Solar/Wind/Generator simulations

**Fig 4.50** below shows the electricity production in which over 90% of the power is from solar while the rest is shared evenly by wind and generator.



**Fig 4.50** Solar/Wind/Generator micro monthly electricity Production

**Table 4.26** and **Fig 4.51** below show Solar/Wind/Generator micro average monthly electricity Consumption. All annual power produced is able to meet the load demands with an excess of over 24.30% which is stored in batteries.

**Table 4.26** Solar/Wind/Generator hybrid micro grid monthly electricity Consumption

	kWh/yr	%
Jinko Eagle PERC60	183,108	94.60
AWS HC 3.3 kW wind turbine	5,477	2.83
Kohler 48 kW standby	4,995	2.58
Excess electricity	47,026	24.30
Unmet electric load	-	-
Capacity Shortage	-	-

Load	133,470	100.00
------	---------	--------

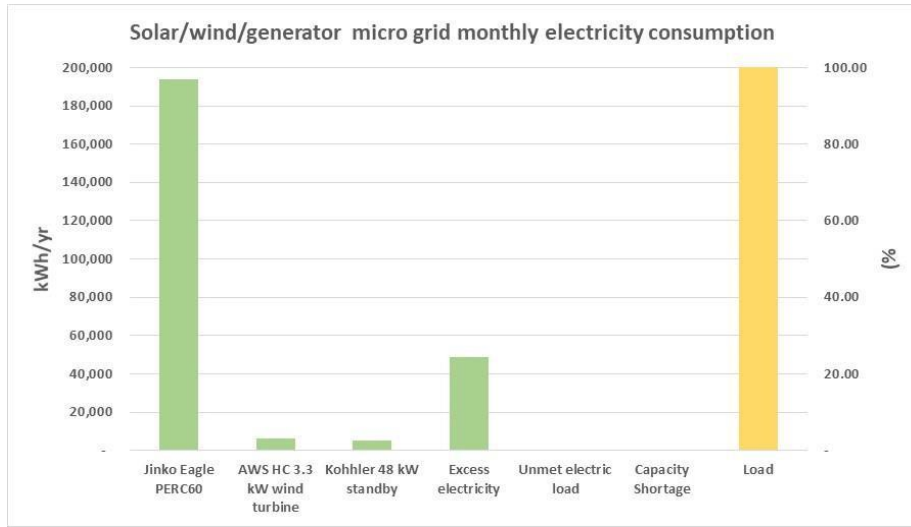


Fig 4.51 Solar/Wind/Generator electricity consumption

Fig 4.52 shows that a generator operates 388 hours annually and burn 1856 litres of diesel as carbon emissions.

Quantity	Value	Units
Hours of Operation	388	hrs/yr
Number of Starts	208	starts/yr
Operational Life	38.7	yr
Capacity Factor	1.19	%
Fixed Generation Cost	31.9	R/hr
Marginal Generation Cost	3.45	R/kWh

Quantity	Value	Units
Electrical Production	4,995	kWh/yr
Mean Electrical Output	12.9	kW
Minimum Electrical Output	12.0	kW
Maximum Electrical Output	44.8	kW

Quantity	Value	Units
Fuel Consumption	1,856	L
Specific Fuel Consumption	0.372	L/kWh
Fuel Energy Input	18,260	kWh/yr
Mean Electrical Efficiency	27.4	%

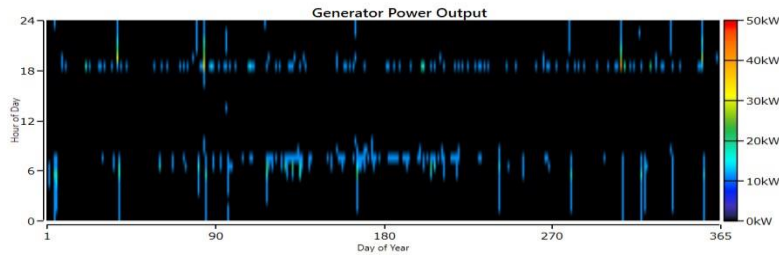


Fig 4.52 Diesel Generator Emissions

Table 4.27 and Fig 4.53 below shows Solar/Wind/generator hybrid micro grid of which the total cost is R11 928 955.71 and LCOE of R5.16/kWh.

Table 4.27 Solar/Wind/Generator total cost

System Configuration	Capital (R)	Replacement (R)	Operating (R)	Fuel (R)	Salvage (R)	NPC (R)	LCOE (R/kWh)	Payback Period (yrs)	IRR (%)	ROI (%)	NPV (R)
AWS HC 3.3kW Wind Turbine	R450,000.00	R164,574.30	R389,725.06	R0.00	-R106,226.65	R898,072.72	5.16	13.64	6.1	4.7	39,868.00
Fronius Symo 20.0-3-M	R106,751.25	R116,031.92	R91,975.11	R0.00	-R21,245.33	R293,512.95					

Hoppecke 24 OPzS 3000	R2,448,000.00	R3,746,447.91	R3,392,166.95	R0.00	-R566,542.12	R9,020,072.74					
Jinko Eagle PERC 60 300W	R702,000.00	R0.00	R117,567.06	R0.00	R0.00	R819,567.06					
Jinko60/300 Dedicated Converter	R70,125.00	R44,699.58	R121,464.31	R0.00	-R11,035.77	R225,253.12					
Kohler 48kW Standby	R171,385.50	R0.00	R24,933.40	R416,243.07	-R26,690.43	R585,871.54					
Other	R0.00	R0.00	R86,605.57	R0.00	R0.00	R86,605.57					
System	R3,948,261.75	R4,071,753.72	R4,224,437.46	R416,243.07	-R731,740.29	R11,928,955.71					

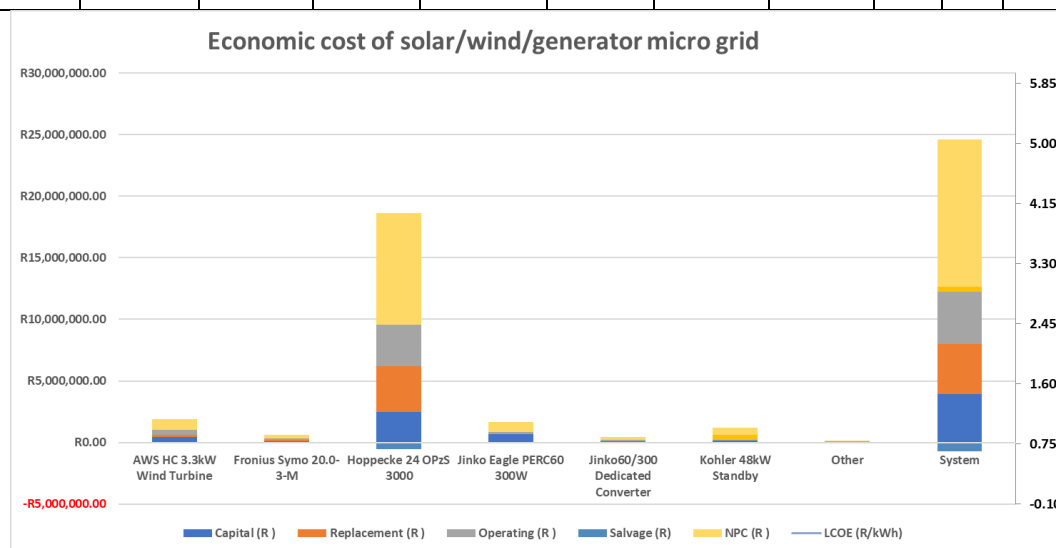


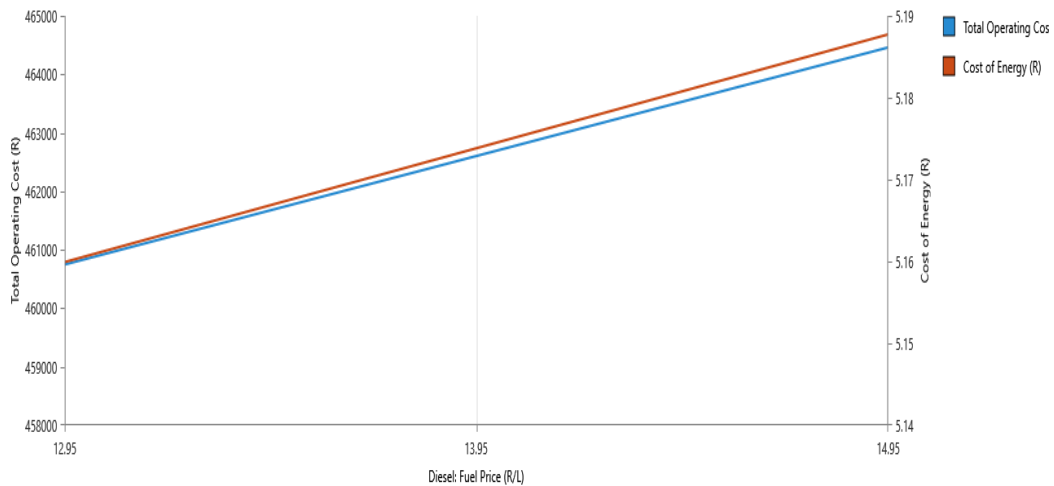
Fig 4.53 Solar/Wind/generator system Cost

#### 4.9.1 NPV, IRR and Payback Period

Net Present Value of this system is R39 868, which shows that this project is viable to the investor because NPV is greater than 0 ( $NPV > 0$ ). The internal rate of return is 6.1 % which might yield some profit depending on the rate of interest that accrues to the borrower of funds for the project. Return on investment is 4.7% which shows that the project is profitable. The payback period of the loan is 13.64 years if this project is financed by debt from borrowers.

#### 4.9.2 Sensitivity Analysis Results

Fig 4.54 below shows the graph for sensitivity results of Solar/wind/Generator hybrid micro grid system. Solar/wind/Generator hybrid micro grid system is sensitive to changes in the price of diesel for the generator.

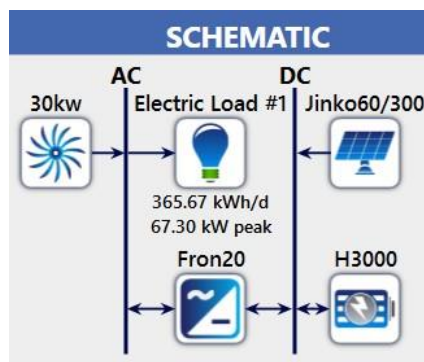


**Fig 4.54** Sensitivity analysis results

As the diesel price increases from R13.00/litre to R14.00/litre and to R15.00/litre, the COE increases from R5.16/kWh to R5.17/kWh and to R5.19/kWh respectively, which shows that the cost of energy is becoming expensive for the consumer. This means that this option of *Solar/Wind/Generator hybrid micro grid configuration* is economically viable compared to LCOE of R5.00/kWh (USD \$0.344/kWh) from One Power’s PV/battery hybrid at Ha Makeme [107].

#### 4.10 Solar/hydro hybrid micro grid system configuration

All the components that were used for **Solar** system configuration will be used for this system configuration. In addition, 20 kW Radial Pipe for Hydro Turbine for Mountain Area was chosen for this study. **Fig 4.55** below shows the system configuration for Solar/hydro hybrid micro grid for the supply of energy to Ha Lehloara.



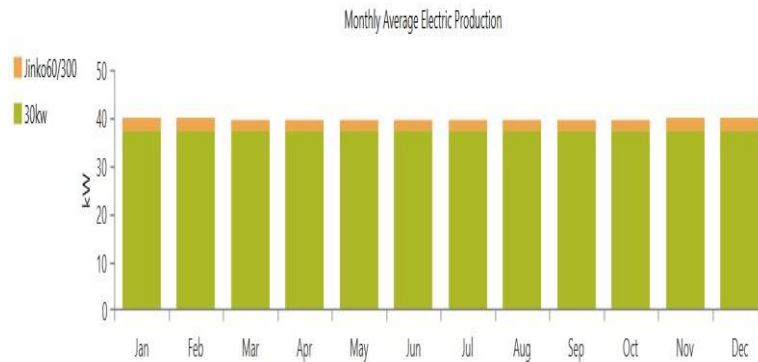
**Fig 4.55** Solar/hydro hybrid micro grid system configuration

**Fig 4.56** below shows Solar/hydro hybrid micro grid system simulations. Power from solar is 30 kW, while from hydro is 29.4 kW.

Architecture										
			Jinko60/300 (kW)	Jinko60/300-MPPT (kW)	H3000	30kw (kW)	Fron20 (kW)	Efficiency1	Dispatch	COE (R)
			30.0	5.00		29.4	20.0	1.00	LF	R7.95
			30.0	5.00		29.4	20.0	0	CC	R7.95
			30.0	5.00		29.4	20.0	0	LF	R7.95
			30.0	5.00		29.4	20.0	1.00	CC	R7.95
			30.0	0		29.4	25.0	1.00	LF	R7.96

**Fig 4.56** Solar/hydro hybrid micro grid system simulations

**Fig 4.57** shows the Solar/hydro hybrid micro grid uniform electricity production, in which over 94% comes from hydro and the rest comes from generator.



**Fig 4.57** Solar/hydro hybrid micro grid electricity consumption

**Table 4.28** and **Fig 4.58** below show the Solar/hydro's monthly average electricity consumption. Despite over 90% annual power production, there is still an annual shortage of about 1.6 %, which is not able to meet annual load.

**Table 4.28** Solar/hydro electricity consumption

	kWh/yr	%
Jinko Eagle PERC60	19,254	5.53
hydropower	328,704	94.50
Excess electricity	216,620	62.30
Unmet electric load	2,133	1.60
Capacity Shortage	2,176	1.63
Load	131,336	100.00

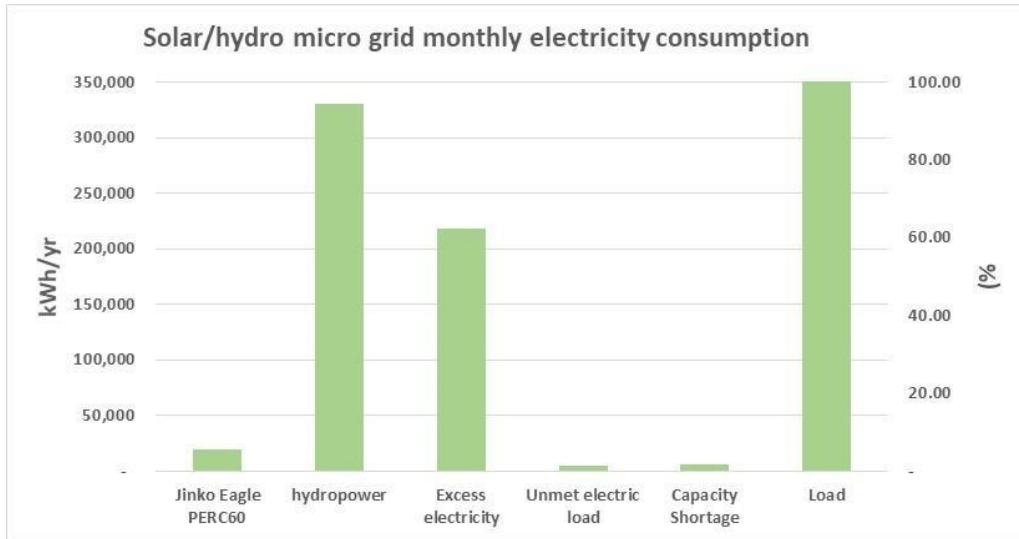


Fig 4.58 Solar/Hydro electricity consumption

Table 4.29 and Fig 4.59 below show the cost of Solar/hydro microgrid, of which the total cost is R22 577 163.47 and LCOE is R9.92/kWh.

Table 4.29 Solar/Hydro total cost

System Configuration	Capital (R )	Replacement (R )	Operating (R )	Fuel (R )	Salvage (R )	NPC (R )	LCOE (R/kWh)
30kw Water Pipe in Pipe out Hydro Turbine	R15,075,000.00	R0.00	R2,611,157.92	R0.00	R0.00	R17,686,157.92	9.92
Fronius Symo 20.0-3-M	R47,445.00	R51,569.74	R40,877.83	R0.00	-R9,442.37	R130,450.20	
Hoppecke 24 OPzS 3000	R1,224,000.00	R1,873,223.96	R1,696,083.47	R0.00	-R283,271.06	R4,510,036.37	
Jinko Eagle PERC60 300W	R140,400.00	R0.00	R23,513.41	R0.00	R0.00	R163,913.41	
Other	R0.00	R0.00	R86,605.57	R0.00	R0.00	R86,605.57	
System	R16,486,845.00	R1,924,793.70	R4,458,238.20	R0.00	-R292,713.43	R22,577,163.47	

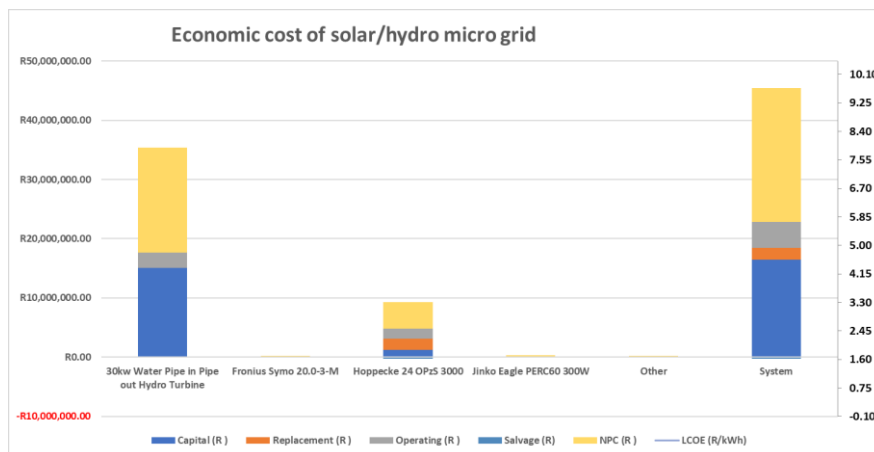
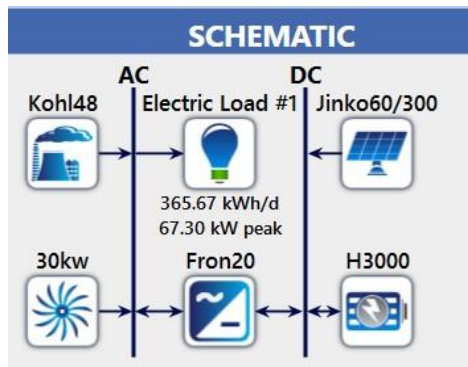


Fig 4.59 Solar/Hydro system cost

### 4.11 Solar/hydro/diesel generator system configuration

All the components that were used for Solar/Hydro system configuration will be used for this system configuration. In addition, the generator that was used in the previous system configurations will also be used for this system. **Fig 4.60** shows the system configuration for Solar/hydro/diesel generator for the supply of energy to Ha Lehloara.



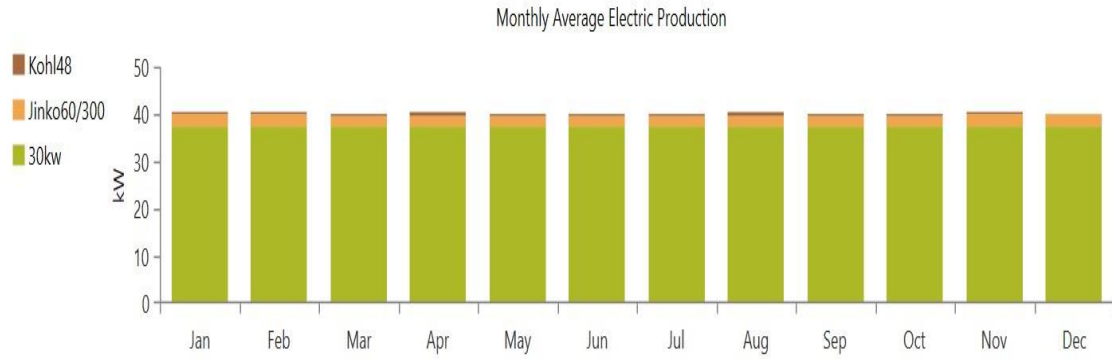
**Fig 4.60** Solar/Hydro/Generator system configuration

**Fig 4.61** below shows Solar/hydro/generator system simulations. The power from solar is 30 kW, from hydro is 29.4 kW while from the generator is 48 kW.

	Jinko60/300 (kW)	Jinko60/300-MPPT (kW)	Kohl48 (kW)	H3000	30kw (kW)	Fron20 (kW)	Efficiency1	Dispatch	COE (R)	NPC (R)
	30.0	5.00	48.0		29.4	20.0	1.00	LF	R8.04	R18.6M
	30.0	5.00	48.0		29.4	20.0	0	CC	R8.04	R18.6M
	30.0	5.00	48.0		29.4	20.0	0	LF	R8.04	R18.6M
	30.0	5.00	48.0		29.4	20.0	1.00	CC	R8.04	R18.6M
	30.0	0	48.0		29.4	25.0	1.00	LF	R8.05	R18.6M
	30.0	0	48.0		29.4	25.0	0	CC	R8.05	R18.6M

**Fig 4.61** Solar/Hydro/generator system simulations

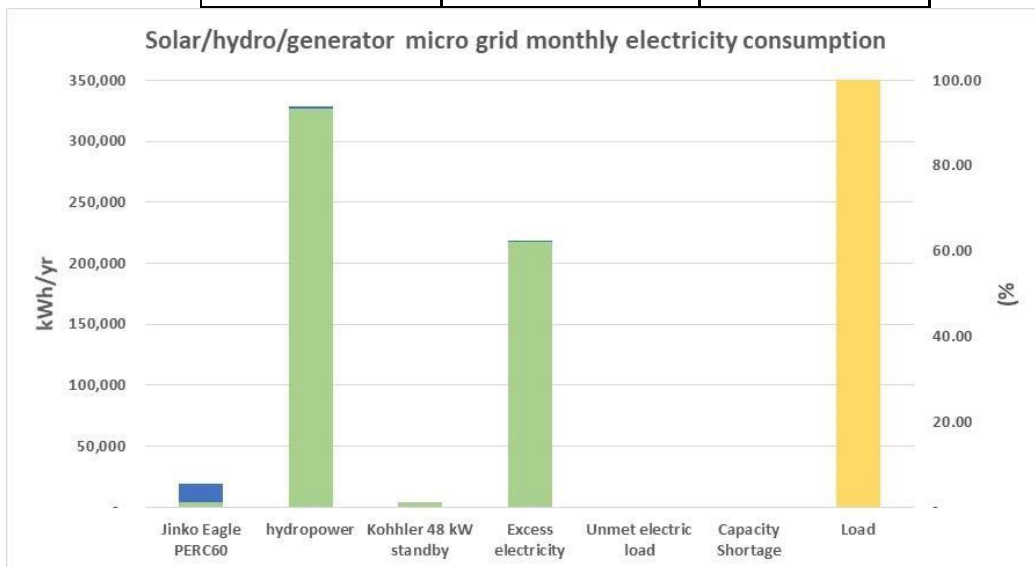
**Fig 4.62** shows the Solar/Hydro/Generator electricity production, in which over 94 % of power comes from hydro, over 5% comes from solar while the rest comes from generator. All annual power produced is able to meet the load demands with an excess of over 61.50 which is stored on batteries.



**Fig 4.62** Solar/hydro/generator electricity consumption

**Table 4.30** and **Fig 4.63** below shows Solar/hydro/generator electricity consumption. **Table 4.30** Solar/hydro/generator electricity consumption

	kWh/yr	%
Jinko Eagle PERC60 300W	19,254	5.53
Kohhler 48 kW standby	132	0.0379
hydro 30 kW	328,704	94.40
Excess electricity	214,248	61.50
Unmet electric load	-	-
Capacity Shortage	-	-
Load	133,470	100



**Fig 4.63** Solar/Hydro/Generator electricity consumption

**Fig 4.64** below shows that a generator operates 388 hours annually and burn 1856 litres of diesel as carbon emissions.

Quantity	Value	Units
Hours of Operation	320	hrs/yr
Number of Starts	252	starts/yr
Operational Life	46.9	yr
Capacity Factor	0.975	%
Fixed Generation Cost	31.9	R/hr
Marginal Generation Cost	3.45	R/kWh

Quantity	Value	Units
Electrical Production	4,102	kWh/yr
Mean Electrical Output	12.8	kW
Minimum Electrical Output	12.0	kW
Maximum Electrical Output	29.7	kW

Quantity	Value	Units
Fuel Consumption	1,526	L
Specific Fuel Consumption	0.372	L/kWh
Fuel Energy Input	15,014	kWh/yr
Mean Electrical Efficiency	27.3	%

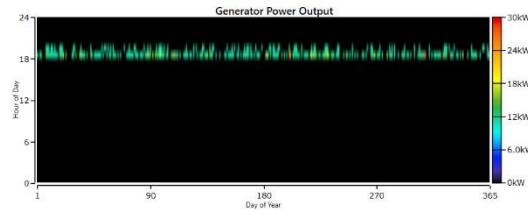
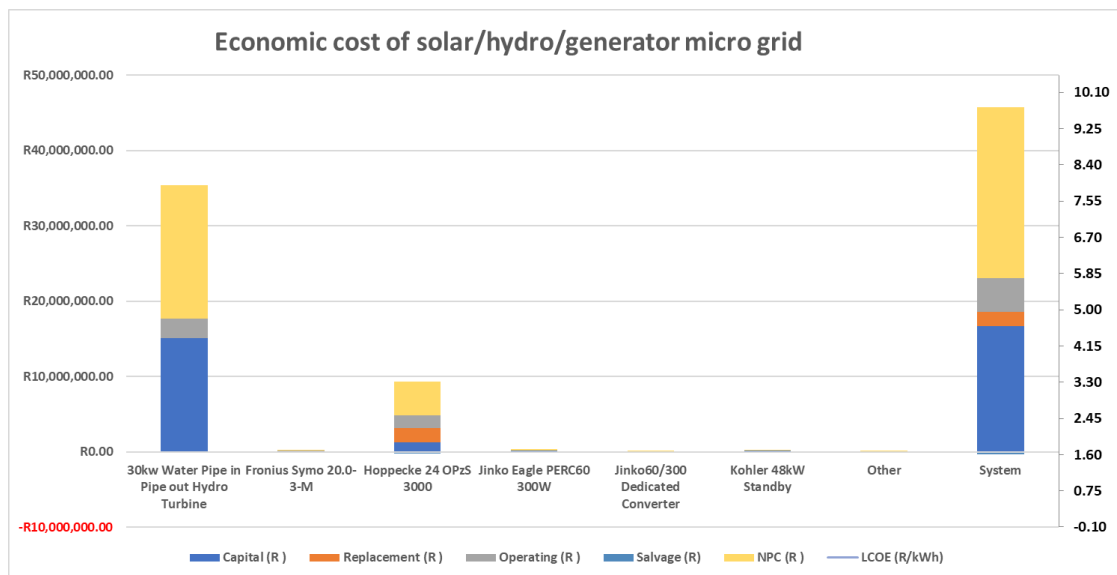


Fig 4.64 Diesel Generator fuel consumption

Table 4.31 and Fig 4.65 below show the cost of the Solar/hydro/generator system, of which the total cost is R22 706 805.97 and LCOE is R9.82/kWh.

Table 4.31 Solar/Hydro/Generator total cost

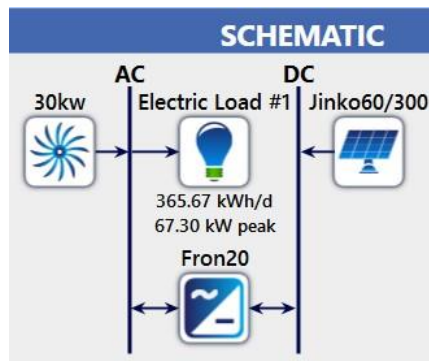
System Configuration	Capital (R)	Replacement (R)	Operating (R)	Fuel (R)	Salvage (R)	NPC (R)	LCOE (R/kWh)
30kw Water Pipe in Pipe out Hydro Turbine	R15,075,000.00	R0.00	R2,611,157.92	R0.00	R0.00	R17,686,157.92	9.82
Fronius Symo 20.0-3-M	R47,445.00	R51,569.74	R40,877.83	R0.00	-R9,442.37	R130,450.20	
Hoppecke 24 OPzS 3000	R1,224,000.00	R1,873,223.96	R1,696,083.47	R0.00	-R283,271.06	R4,510,036.37	
Jinko Eagle PERC60 300W	R140,400.00	R0.00	R23,513.41	R0.00	R0.00	R163,913.41	
Jinko60/300 Dedicated Converter	R6,375.00	R4,063.60	R11,042.21	R0.00	-R1,003.25	R20,477.56	
Kohler 48kW Standby	R171,385.50	R0.00	R706.87	R11,226.64	-R74,154.07	R109,164.94	
Other	R0.00	R0.00	R86,605.57	R0.00	R0.00	R86,605.57	
System	R16,664,605.50	R1,928,857.30	R4,469,987.29	R11,226.64	-R367,870.75	R22,706,805.97	



*Fig 4.65 Solar/Hydro/Generator system cost*

#### 4.12 Solar without storage/hydro system configuration

All the components except battery that were used for **Solar** system configuration will be used for this system configuration. In addition, 20 kW Radial Pipe for Hydro Turbine for Mountain Area was chosen for this study. **Fig 4.66** below shows the system configuration for Solar without battery/hydro hybrid micro grid for the supply of energy to Ha Lehloara.



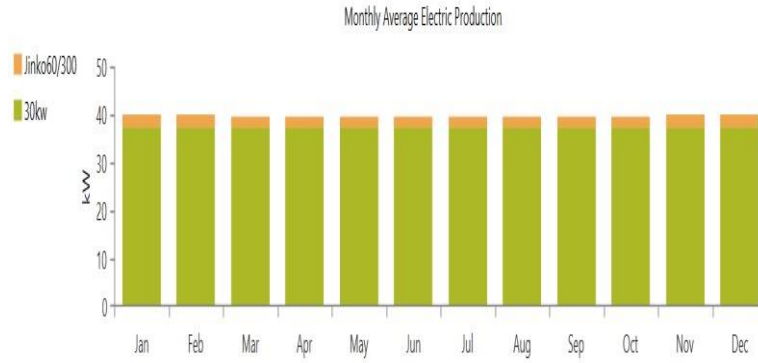
*Fig 4.66 Solar without battery/hydro hybrid micro grid system configuration*

**Fig 4.67** below shows Solar without battery/hydro hybrid micro grid system simulations. Power from solar is 30 kW, while from hydro is 29.4 kW.

			Jinko60/300 (kW)	Jinko60/300-MPPT (kW)	30kw (kW)	Fron20 (kW)	Efficiency1	Dispatch	COE (R)
			30.0	5.00	29.4	20.0	1.00	CC	R7.95
			30.0	5.00	29.4	20.0	0	CC	R7.95
			30.0	5.00	29.4	20.0	1.00	LF	R7.95

*Fig 4.67 Solar without battery/hydro hybrid micro grid system simulations*

**Fig 4.68** shows the Solar/hydro hybrid micro grid uniform electricity production, in which over 94% comes from hydro and the rest comes from generator.

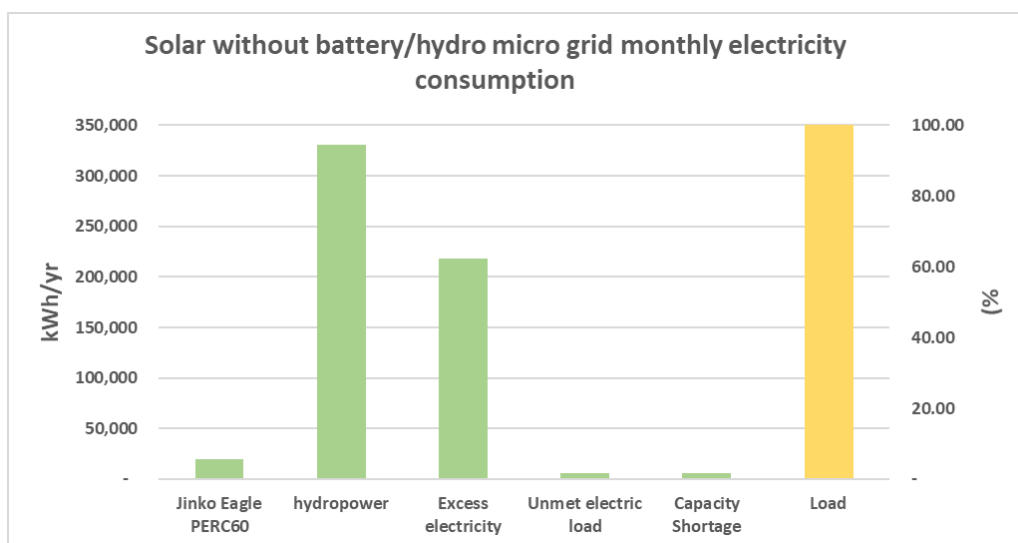


**Fig 4.68** Solar/hydro hybrid micro grid electricity consumption

**Table 4.32** and **Fig 4.69** below show the Solar/hydro’s monthly average electricity consumption. Despite over 90% annual power production, there is still an annual shortage of about 1.6 %, which is not able to meet annual load.

**Table 4.32** Solar without battery/hydro electricity consumption

	kWh/yr	%
Jinko Eagle PERC60	19,254	5.53
hydropower	328,704	94.50
Excess electricity	216,620	62.30
Unmet electric load	2,133	1.60
Capacity Shortage	2,176	1.63
Load	131,336	100.00

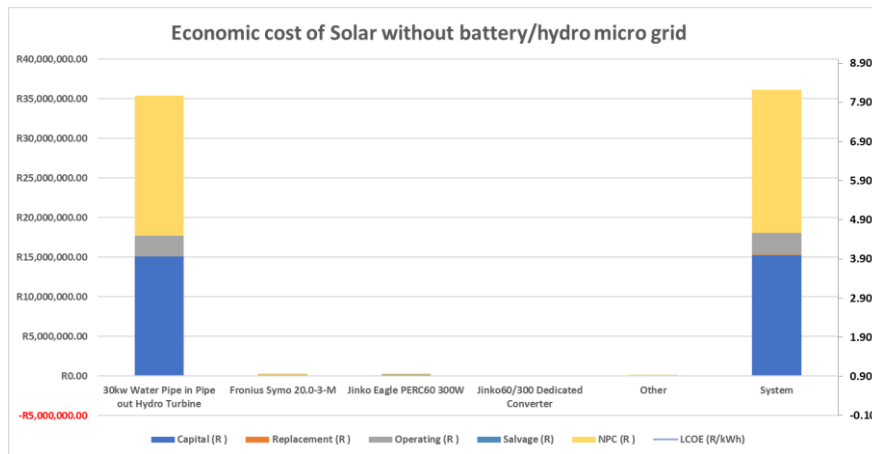


**Fig 4.69** Solar without battery/Hydro electricity consumption

**Table 4.33** and **Fig 4.70** below show the cost of Solar/hydro micro grid, of which the total cost is R18 087 604.66 and LCOE is R7.95/kWh.

**Table 4.33** Solar without battery/Hydro total cost

System Configuration	Capital (R )	Replacement (R )	Operating (R )	Fuel (R )	Salvage (R)	NPC (R )	LCOE (R/kWh)
30kw Water Pipe in Pipe out Hydro Turbine	R15,075,000.00	R0.00	R2,611,157.92	R0.00	R0.00	R17,686,157.92	7.95
Fronius Symo 20.0-3-M	R47,445.00	R51,569.74	R40,877.83	R0.00	-R9,442.37	R130,450.20	
Jinko Eagle PERC60 300W	R140,400.00	R0.00	R23,513.41	R0.00	R0.00	R163,913.41	
Jinko60/300 Dedicated Converter	R6,375.00	R4,063.60	R11,042.21	R0.00	-R1,003.25	R20,477.56	
Other	R0.00	R0.00	R86,605.57	R0.00	R0.00	R86,605.57	
System	R15,269,220.00	R55,633.34	R2,773,196.94	R0.00	-R10,445.62	R18,087,604.66	



**Fig 4.70** Solar without battery/hydro micro grid system cost

### 4.13 Solar/hydro/wind system configuration

All the components that were used in solar micro grid and wind micro grid will also be used for this system configuration. In addition, the 20 kW Radial Pipe used for the Hydro Turbine for Mountain Area was chosen for this system. **Table 4.34** below shows the datasheet of 20 kW Radial in Pipe Hydro Turbine [109].

**Table 4.34** Datasheet of 20 kW Radial in Pipe Hydro Turbine

Full flow water pipe diameter	Power output per Water head(m)					
	3m	5m	10m	20m	30m	40m
65mm				1.5kw	2kw	3kw
80mm			1.5kw	2kw	3kw	5kw
100mm		2kw	3kw	5kw/6.5kw	8kw/10kw	12kw/15kw
150mm		3kw	5kw	10kw	15kw	20kw
200mm	3kw	5kw	10kw	20kw	30kw	40kw
250mm	3kw	5kw/8kw	15kw	30kw	40kw/45kw	

Fig 4.71 shows the system configuration for Solar/hydro/wind micro grid for the supply of energy to Ha Lehloara.

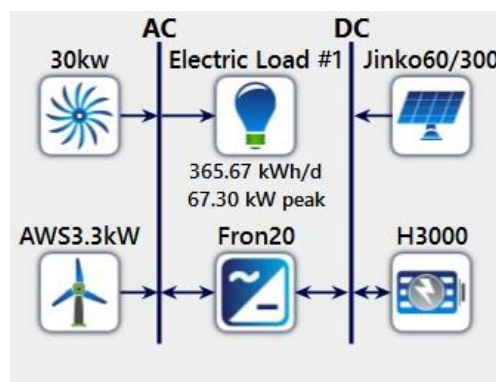


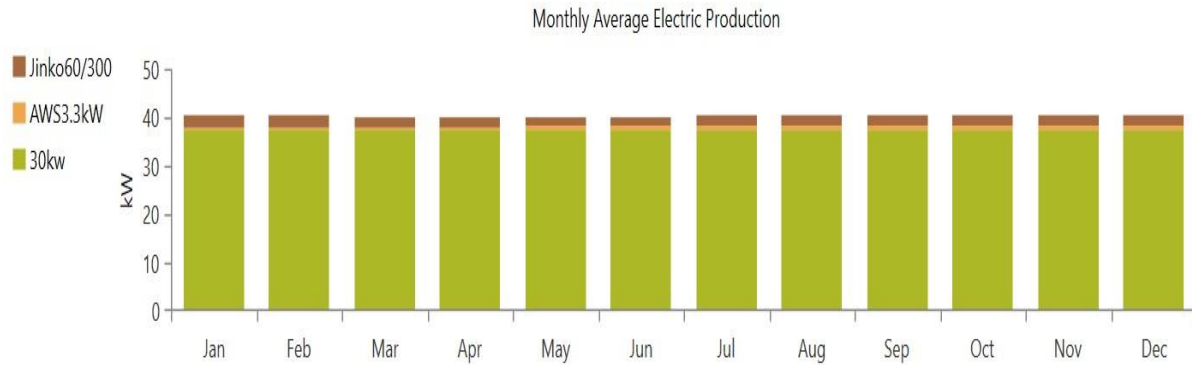
Fig 4.71 Solar/hydro/Wind configuration

Fig 4.72 below shows optimisation results. The power from solar is 30 kW, from hydro is 29.4 kW while from wind is 1 kW.

Optimization Results												
Architecture											Cost	
Jinko60/300 (kW)	Jinko60/300-MPPT (kW)	AWS3.3kW	H3000	30kW (kW)	Fron20 (kW)	Efficiency1	Dispatch	COE (R)	NPC (R)	Operating cost (R/yr)		
30.0	5.00	1		29.4	20.0	1.00	LF	R8.33	R19.0M	R188,582		
30.0	5.00	1		29.4	20.0	0	CC	R8.33	R19.0M	R188,582		
30.0	5.00	1		29.4	20.0	0	LF	R8.33	R19.0M	R188,582		
30.0	5.00	1		29.4	20.0	1.00	CC	R8.33	R19.0M	R188,582		
30.0	0	1		29.4	25.0	1.00	LF	R8.34	R19.0M	R188,966		

Fig 4.72 Solar/hydro/Wind configuration

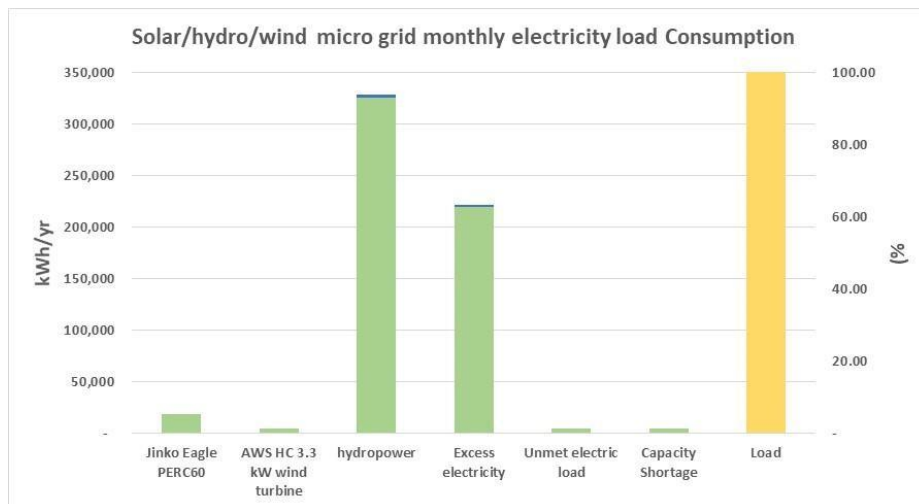
**Fig 4.73** below shows the electricity production from this system. Over 90 % of electricity produced, comes from hydro and over 5% comes from solar, while over 1% comes from the generator.



**Fig 4.73** Solar/Hydro/Wind electricity production

**Table 4.35** and **Fig 4.74** below show the Solar/Hydro/Wind micro grid average monthly electricity Consumption. Despite over 90% annual power production, there is an annual shortage of about 1.47 %, which implies that the system is not able to meet annual load. **Table 4.35** Solar/Hydro/Wind micro grid monthly electricity Consumption

	kWh/yr	%
Jinko Eagle PERC60	19,254	5.45
AWS HC 3.3 kW wind turbine	5,260	1.49
hydropower	328,704	93.10
Excess electricity	221,667	62.80
Unmet electric load	1,920	1.44
Capacity Shortage	1,963	1.47
Load	131,549	100.00

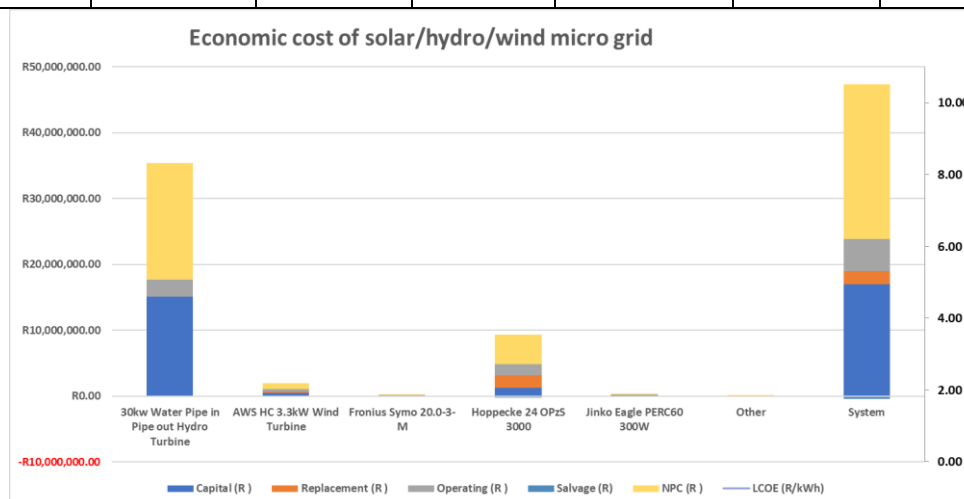


*Fig 4.74 Solar/Hydro/Wind Consumption*

**Table 4.36** and **Fig 4.75** below show the cost of the Solar/Hydro/Wind micro grid system, of which the total cost is R23 475 236.19 and LCOE is R10.30/kWh.

**Table 4.36** Solar/Hydro/Wind total cost

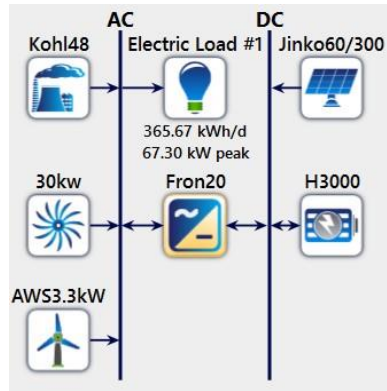
System Configuration	Capital (R)	Replacement (R)	Operating (R)	Fuel (R)	Salvage (R)	NPC (R)	LCOE (R/kWh)
30kw Water Pipe in Pipe out Hydro Turbine	R15,075,000.00	R0.00	R2,611,157.92	R0.00	R0.00	R17,686,157.92	10.30
AWS HC 3.3kW Wind Turbine	R450,000.00	R164,574.30	R389,725.06	R0.00	-R106,226.65	R898,072.72	
Fronius Symo 20.0-3-M	R47,445.00	R51,569.74	R40,877.83	R0.00	-R9,442.37	R130,450.20	
Hoppecke 24 OPzS 3000	R1,224,000.00	R1,873,223.96	R1,696,083.47	R0.00	-R283,271.06	R4,510,036.37	
Jinko Eagle PERC60 300W	R140,400.00	R0.00	R23,513.41	R0.00	R0.00	R163,913.41	
Other	R0.00	R0.00	R86,605.57	R0.00	R0.00	R86,605.57	
System	R16,936,845.00	R2,089,368.00	R4,847,963.27	R0.00	-R398,940.08	R23,475,236.19	



*Fig 4.75 Solar/hydro/wind cost*

#### 4.14 Solar/ Hydro/Wind/Generator system configuration

All the components that were used for the Solar/Wind system configuration will be used for this system configuration, with an addition of a generator. **Fig 4.76** shows the system configuration for Solar/Hydro/Wind/Generator micro grid for the supply of energy to Ha Lehloara.



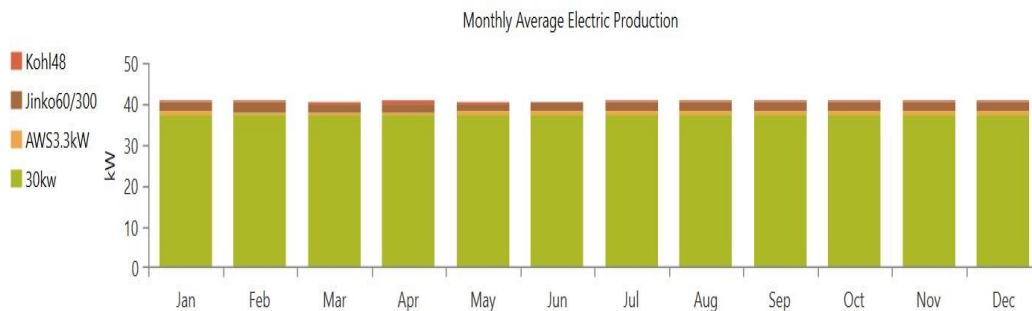
**Fig 4.76** Solar/Hydro/Wind/Generator configuration

**Fig 4.77** below shows Solar/Hydro/Wind/Generator system simulations. The power from solar is 30 kW, from hydro is 29.4 kw while from wind is 1 kW and 48 kW comes from generator.

	Jinko60/300 (kW)	Jinko60/300-MPPT (kW)	AWS3.3kW	Kohl48 (kW)	H3000	30kw (kW)	Fron20 (kW)	Efficiency1	Dispatch	COE (R)
	30.0	5.00	1	48.0		29.4	20.0	1.00	LF	R8.41
	30.0	5.00	1	48.0		29.4	20.0	0	CC	R8.41
	30.0	5.00	1	48.0		29.4	20.0	0	LF	R8.41
	30.0	5.00	1	48.0		29.4	20.0	1.00	CC	R8.41
	30.0	0	1	48.0		29.4	25.0	1.00	LF	R8.42

**Fig 4.77** Solar/Hydro/Wind/Generator optimisation results

**Fig 4.78** shows the solar/hydro/wind/generator microgrid system’s electricity production. Over 90 % of electricity produced comes from hydro, over 5% comes from solar while over 1% comes from generator.

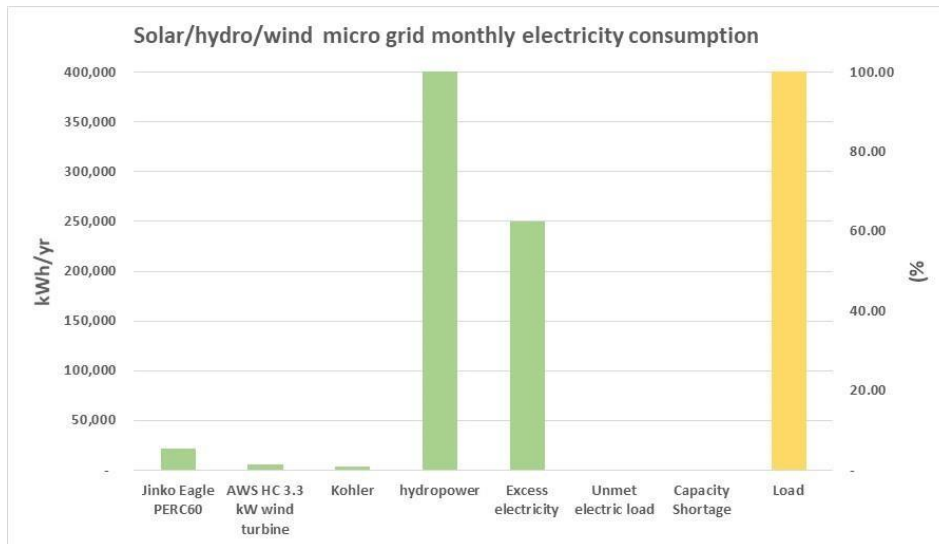


**Fig 4.78** Solar/Hydro/Wind/ /generator micro grid system electricity production

**Table 4.37** and **Fig 4.79** below show the Solar/Hydro/Wind/Generator microgrid system electricity consumption. The electricity consumption from this system configuration shows that all the village load will be met and there will be no shortage of electricity. An excess electricity of 62.20% will be stored on the battery bank.

**Table 4.37** Solar/ Hydro/Wind/Generator electricity consumption

	kWh/yr	%
Hydro	328,704	93.00
Jinko Eagle PERC60	19,254	5.45
AWS HC 3.3 kW wind turbine	5,477	1.55
Kohler 48 kW standby	96	0.03
Excess electricity	219,724	62.20
Unmet electric load	-	-
Capacity Shortage	-	-
Load	133,470	100.00



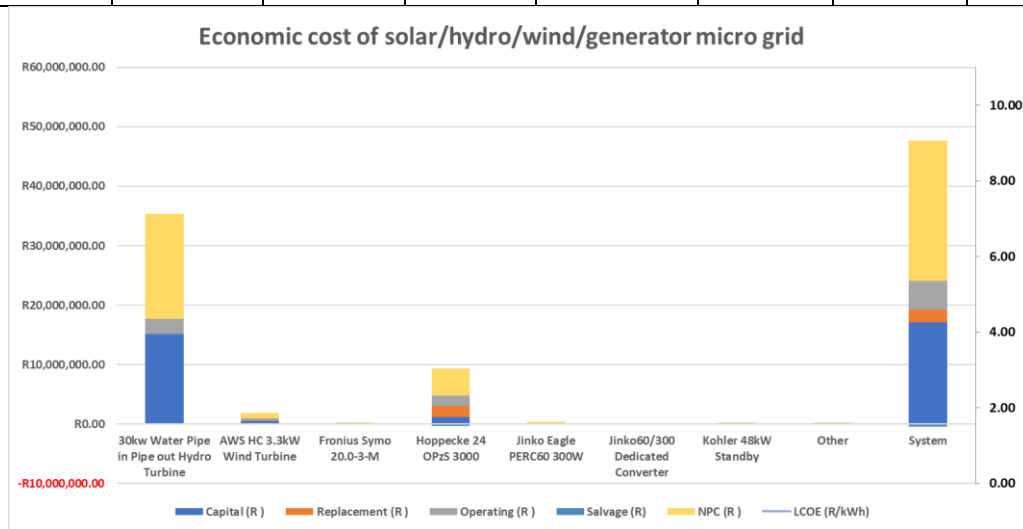
**Fig 4.79** Solar/Hydro/Wind/generator electricity consumption

**Table 4.38** and **Fig 4.80** below show the cost of Hydro/Wind/Solar/generator system, of which total cost is R23 601 246.40 and LCOE is R10.21/kWh.

**Table 4.38** Solar/Hydro/Wind/generator system cost

System Configuration	Capital (R)	Replacement (R)	Operating (R)	Fuel (R)	Salvage (R)	NPC (R)	LCOE (R/kWh)
30kw Water Pipe in Pipe out Hydro Turbine	R15,075,000.00	R0.00	R2,611,157.92	R0.00	R0.00	R17,686,157.92	10.21
AWS HC 3.3kW Wind Turbine	R450,000.00	R164,574.30	R389,725.06	R0.00	-R106,226.65	R898,072.72	

Fronius Symo 20.0-3-M	R47,445.00	R51,569.74	R40,877.83	R0.00	-R9,442.37	R130,450.20	
Hoppecke 24 OPzS 3000	R1,224,000.00	R1,873,223.96	R1,696,083.47	R0.00	-R283,271.06	R4,510,036.37	
Jinko Eagle PERC60 300W	R140,400.00	R0.00	R23,513.41	R0.00	R0.00	R163,913.41	
Jinko60/300 Dedicated Converter	R6,375.00	R4,063.60	R11,042.21	R0.00	-R1,003.25	R20,477.56	
Kohler 48kW Standby	R171,385.50	R0.00	R514.09	R8,164.83	-R74,531.76	R105,532.65	
Other	R0.00	R0.00	R86,605.57	R0.00	R0.00	R86,605.57	
System	R17,114,605.50	R2,093,431.60	R4,859,519.57	R8,164.83	-R474,475.09	R23,601,246.40	



*Fig 4.80 Solar/Hydro/Wind/Generator system cost*

## 4.15 DISCUSSIONS

### 4.15.1 Analysis of different system configurations

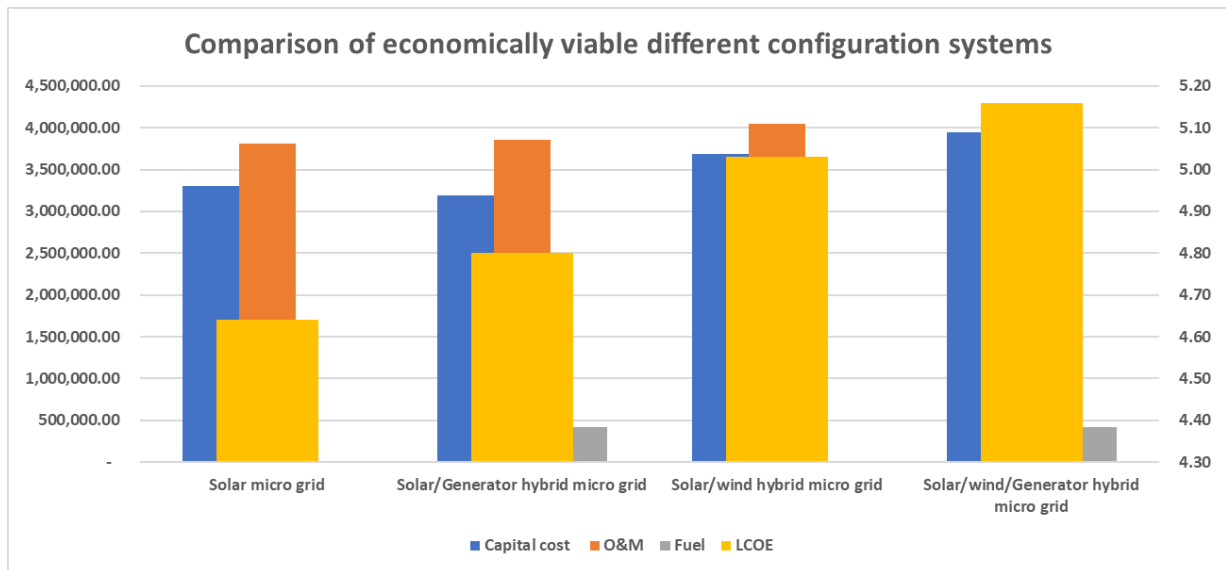
All system configurations that included a component of hydro, were found to be not economically viable mainly because of the high civil works involved in the construction of diversion weir and power house. Civil works involve construction of diversion weir, power channel, forebay, penstock, building of powerhouse, tail race channel and desilting tank [110]. The cost/kWh of building the hydropower micro grid system will be R15 000 000/365.67 kWh = R41020.59/kWh (USD \$2734/kWh), which is too high, while the installed cost of hydropower station between 2010 and 2019 was in the range USD \$600/kWh to USD \$4500/kWh [111]. Small hydropower projects normally have very high investments costs per kWh because of small capacities installed [111]. There will be a need for civil works in order to construct weir to channel water to micro grid station. The hydro power scheme will be costly for micro grid for the Malibamatšo river, with an average discharge of about 14.34 m<sup>3</sup>/s. The

huge capital cost for hydro will be the deterrent that will prevent hydro from coming into the energy mix. Hydro will be suitable for a small stream whose discharge is below 14.34 m<sup>3</sup>/s. Residual flow means the flow that will still pass through in order to support both human and aquatic life beyond the stream. Batteries are not needed for hydro power because there will be very huge batteries needed to store that hydro power, and the batteries are very expensive. Also, except for dry seasons, water flows during the day and at night. Since, the load is small which is 365.67 kWh/day, the cost of hydro power is very expensive for this size of project.

The clearness index is highest in winter (in June and July) because during winter season there are no clouds in the sky. It starts increasing from April and drops in August. The Clearness index is lowest in December and January because these are summer months and there are a lot of clouds which normally result in more rainfall. Therefore, during winter, the sky is usually clear which result in higher clearness index than in summer when the sky is usually covered with clouds. Table 4.39 and Fig 4.81 below show the differences in terms of capital, operating, fuel costs and LCOE for four economically viable system configurations namely: *Solar micro grid*, *Solar /Generator hybrid micro grid*, *Solar/Wind hybrid micro grid* and *Solar/wind/Generator hybrid micro grid*.

**Table 4.39** Comparison of economically viable different systems configuration

<b>Configuration</b>	<b>Capital cost</b>	<b>O&amp;M</b>	<b>Fuel</b>	<b>LCOE</b>
Solar micro grid	3,297,990.00	3,806,682.85	-	4.64
Solar/Generator hybrid micro grid	3,194,950.00	3,852,576.18	415,124.73	4.80
Solar/wind hybrid micro grid	3,682,953.75	4,045,968.84	-	5.03
Solar/wind/Generator hybrid micro grid	3,948,261.75	4,224,437.46	416,243.07	5.16



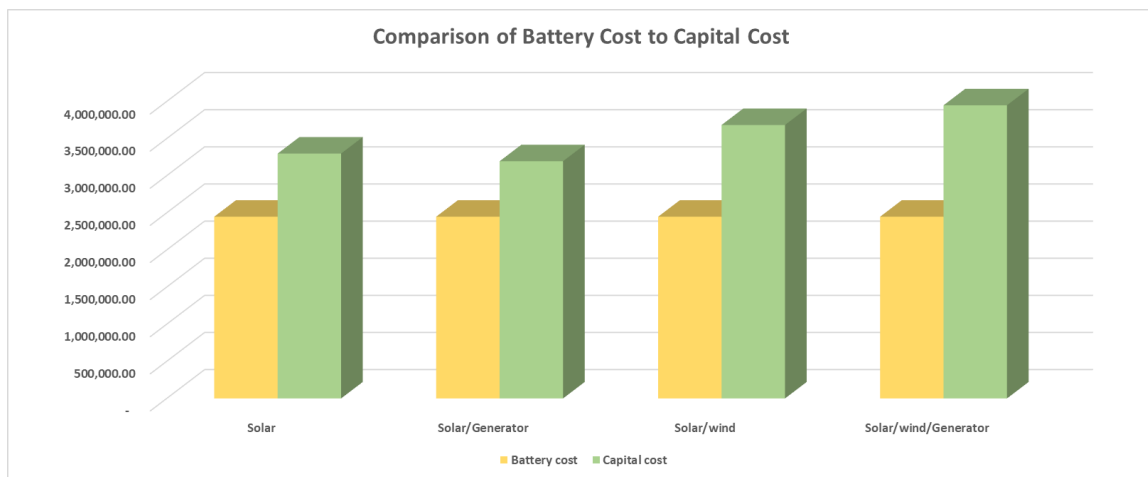
**Fig 4.81** Comparison of Capital, Operating, Fuel costs and LCOE

The most economically viable is *Solar micro grid* system configuration with the LCOE of R4.64/kWh (USD \$0.309/kWh) and both Capital and O/M cost close to R7 000 000. This is followed by *Solar/Generator hybrid micro grid*, and the third economically viable system configuration is *Solar/Wind hybrid micro grid*, while the *Solar/wind/Generator hybrid micro grid* system configuration is last. In terms of reliability *Solar/wind/Generator hybrid micro grid* system configuration is more reliable because it uses different sources of energy mainly solar, wind and generator. This means *Solar/wind/Generator hybrid micro grid* with LCOE of R5.16/kWh (US \$0.43/kWh) system configuration addresses intermittency and availability of power at all times. Reliability and cost-effectiveness are the main drivers of constructing hybrid micro grids systems [112]. It must also be emphasised that compared to current electricity tariff of R1.34 /kWh from Lesotho Electricity Company, R4.64/ kWh or R5.16/kWh is still expensive if there are no private investors to construct these micro grids. Lastly, **Table 4.40** and **Fig. 4.82** below, show comparison of viable systems, in terms of battery cost to Capital cost.

**Table 4.40** Cost of battery to Capital cost

Configuration	Battery cost	Capital cost	%(Battery/Capital)
Solar	2,448,000.00	3,297,990.00	74%
Solar/Generator	2,448,000.00	3,194,950.00	77%
Solar/wind	2,448,000.00	3,682,953.75	66%
Solar/wind/Generator	2,448,000.00	3,948,261.75	62%

**Fig 4.82** below shows that cost of batteries contributes to high capital cost of hybrid micro grid systems.



**Fig 4.82** Battery cost comparison

The cost of battery determines the capital cost in each of the above four viable system configurations. The higher the battery cost, the higher the capital cost. The cost of battery bank is above 60% of the capital cost in all of these four system configurations. This high cost of battery bank makes the hybrid micro grid both technically and economically not viable to most communities unless they secure external funding.

#### 4.15.2 Analysis of two best optimal system configurations

The two systems configurations that will be analysed further for technical and economic viability are: *Solar/Wind/Generator hybrid micro grid* and *Solar/Generator hybrid micro grid* from optimisation results.

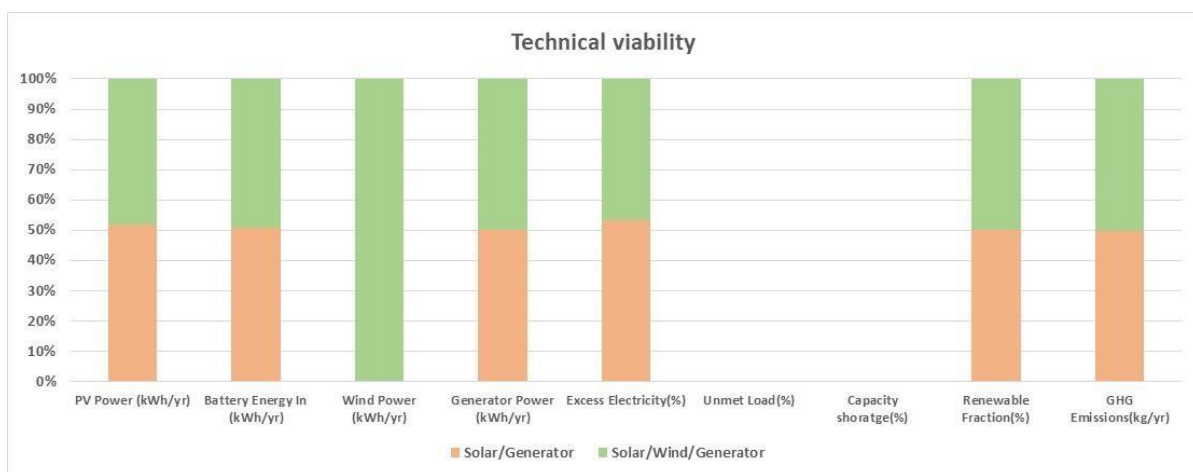
**a) Technical viability and feasibility**

**Table 4.39** below shows the technical values that have been compared and **Fig 4.83** below displays the same data pictorially. From **Table 4.41** below, the *Solar/Generator hybrid micro grid* system configuration shows that the PV output power consumption of 198473 kWh/yr is slightly higher than the PV output power consumption of the *Solar/Wind/Generator hybrid micro grid* of 183108 kWh/yr by 15065 kWh/yr, which is 8.23%. Similarly, power consumption from the generator is almost the same for both system configurations. Both system configurations have renewable fraction of 96.3 %, which is higher than the renewable fraction of 95% that was set in the system constraints. 96.3 % renewable fraction is a good percentage from environmental perspective since emissions of around 4843 kg per year cause less pollution to the atmosphere. These two system configurations have been technically optimised because all daily load is met and there is no capacity shortage.

**Table 4.41** Technical values of two system configurations

System Configuration	PV Power (kWh/yr)	Battery Energy In (kWh/yr)	Wind Power (kWh/yr)	Generator Power (kWh/yr)	Excess Electricity (%)	Unmet Load (%)	Capacity shortage (%)	Renewable Fraction (%)	GHG Emissions(kg/yr)
Solar/Generator	198,473	77,621	-	4,996	27.8	0	0	97.5	4843
Solar/Wind/Generator	183,108	75,526	5,477	4,995	24.3	0	0	96.3	4856

Similarly, from **Fig 4.83** below the values are more or the less the same from these two system configurations except that for *Solar/Wind/Generator hybrid micro grid* energy consumption from wind is around 5477 kWh annually.



**Fig 4.83** Technical values

Therefore, in terms of less emissions of 4843 kg/yr that are being released to the atmosphere by *Solar/Generator hybrid micro grid* system configuration compared to 4856 kg/yr emissions from *Solar/Wind/Generator hybrid micro grid*, it is concluded that *Solar/Generator hybrid micro grid* is the best technically optimised system configuration.

**b) Economic viability and feasibility**

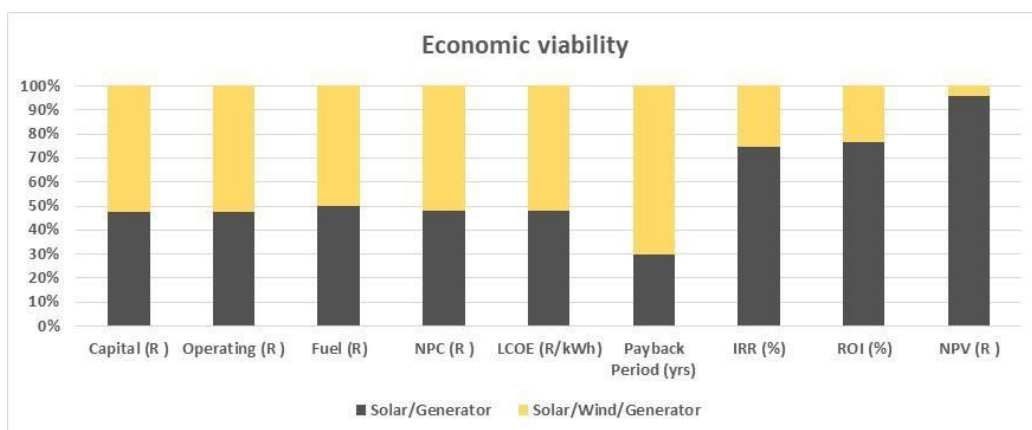
**Table 4.42** below shows economical values from the two system configurations: *Solar/Wind/Generator hybrid micro grid* and *Solar/Generator hybrid micro grid*.

**Table 4.42**

System Configuration	Capital (R)	Operating (R)	Fuel (R)	NPC (R)	LCOE (R/kWh)	Payback Period (yrs)	IRR (%)	ROI (%)	NPV (R)
Solar/Generator	3,551,436.75	3,853,335.37	415,124.73	11,104,119.37	4.80	5.81	18.0	15.5	940,994.00
Solar/Wind/Generator	3,948,261.75	4,224,437.46	416,243.46	11,928,955.71	5.16	13.64	6.1	4.7	39,868.00
Difference	396,825.00	371,102.09	1,118.73	824,836.34	0.36	7.83	11.90	10.80	901126.00
% Change	11.17%	9.63%	0.27%	7.43%	7.50%	134.77%	66.11%	69.68%	95.76%

Economical values of two system configurations

The graph in **Fig 4.84** below shows the pictorial depiction of the same data for these two system configurations.



**Fig 4.84** Economical values

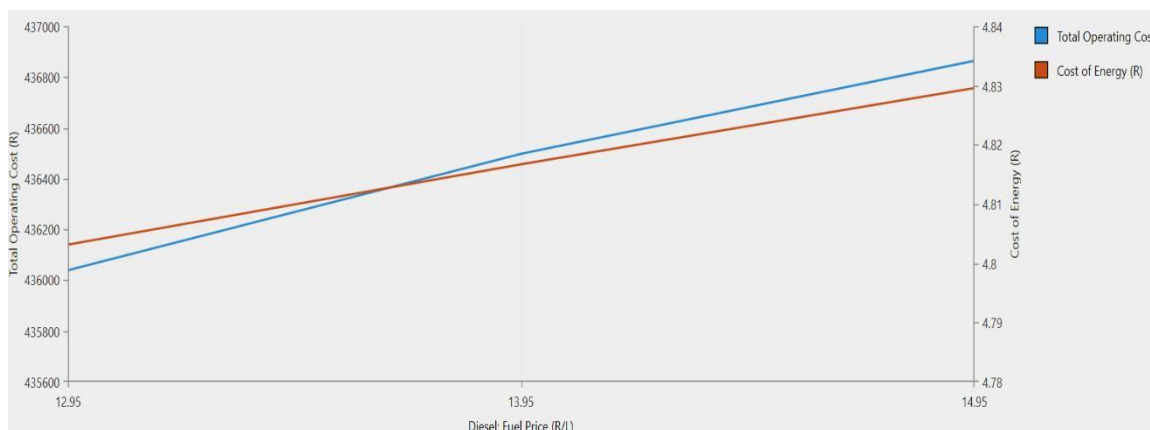
All costs such as Capital, operating and fuel costs are less by 11.17%, 9.63%, 0.27% respectively for *Solar/Generator hybrid micro grid* as compared to the same costs for *Solar/Wind/Generator hybrid micro grid*. Similarly, *Solar/Generator hybrid micro grid* has LCOE of R4.84/ kWh (USD \$0.32 /kWh) which is less than LCOE of R5.16 /kWh (USD \$0.34 /kWh) from the *Solar/Wind/Generator hybrid micro grid*. This means electricity is 7.50% cheaper for *Solar/Generator micro grid as compared to Solar/Wind/Generator hybrid micro grid* system configuration. Furthermore, the LCOE of R4.84/ kWh (USD \$0.32 /kWh) of *Solar micro grid configuration* is economically viable compared to LCOE of R5.00/kWh (USD \$0.344/kWh) by One Power's solar PV/generator hybrid system at the rural village of Ha Makebe [107]. In addition, the findings from Literature show that LCOE of R4.84/ kWh (USD \$0.32 /kWh) of *Solar micro grid configuration* is reasonable. The following are some of such research studies. Optimisation using HOMER was done on hybrid micro grid system of PV, diesel generator and battery off-grid in rural Tambo village which is in Adamawa state in North west Nigeria and was not connected to the grid, had load of 76 kWh/day, Peak of 14 kW and had Levelized Cost of Energy (LCOE) of USD \$0.547 /kWh [77]. The other optimisation of hybrid system of the following configuration: PV, wind, diesel generator and battery as backup system, using HOMER was for the remote village, which was not connected to the grid, called Dembile in Bonke Woreda, which is in SNNPR region in Ethiopia, with energy consumption of 279 kWh/day, peak of 64 kW and Levelized Cost of Energy of US\$0.538 /kWh [78]. The third hybrid is the PV, diesel, and battery as backup system, modelled and optimised with HOMER for a small rural village called Makyiyay in Southern State in Myanmar, with energy consumption of 100 kWh/day, peak of 34 kW and Levelized Cost of Energy of USD \$0.429 /kWh [15]. In addition, the hybrid off grid system modelled and optimised with HOMER for a rural village called Pissila in Burkina Faso had the energy consumption of 711 kWh/day, peak of 81 kW had Levelized Cost of Energy of USD \$ 0.5 /kWh [79]. Lastly, an off grid system in the rural village in Siyambalanduwa District in Sri Lanka, had energy consumption of 270 kWh/day with peak of 25 kW and Levelized Cost of Energy of USD \$0.34 /kWh [80].

Similarly, *Solar/Generator hybrid micro grid* has Return on Investment (ROI) of 15.5% as compared to 4.7% from *Solar/Wind/Generator hybrid micro grid*. This shows that, in terms of ROI, *Solar/Generator hybrid micro grid* provides 69.68% more return to investors than *Solar/Wind/Generator hybrid micro grid*. The *Solar/Generator hybrid micro grid* yields an NPV of R940 994.00 compared to NPV of R39 868.00 from *Solar/Wind/Generator hybrid micro grid*. This means that *Solar/Generator hybrid micro grid* is 95.76% more viable and profitable

than Solar/Wind/Generator hybrid micro grid. Furthermore, payback period of Solar/Generator hybrid micro grid is 5.81 years while that of Solar/Wind/Generator hybrid micro grid is 13.64 years. Hence, the shorter payback of 5.8 years will be more attractive to an investor than a longer payback period of 13.64 years. This shorter payback period of 5.81 years means that an investor will be able to recoup the investment costs from the project within a reasonable time as compared to payback of 13.64 years. Lastly Solar/Generator hybrid micro grid has IRR of 18% which is higher than the 6.1% of Solar/Wind/Generator hybrid micro grid. The higher IRR of 18% means that the project may have a higher rate of return from the project provided NPV and discount rate are considered. Therefore, Solar/Generator hybrid micro grid is more economically viable compared to Solar/Wind/Generator hybrid micro grid system configuration.

### c) Sensitivity Analysis Results of Solar/Generator hybrid micro grid

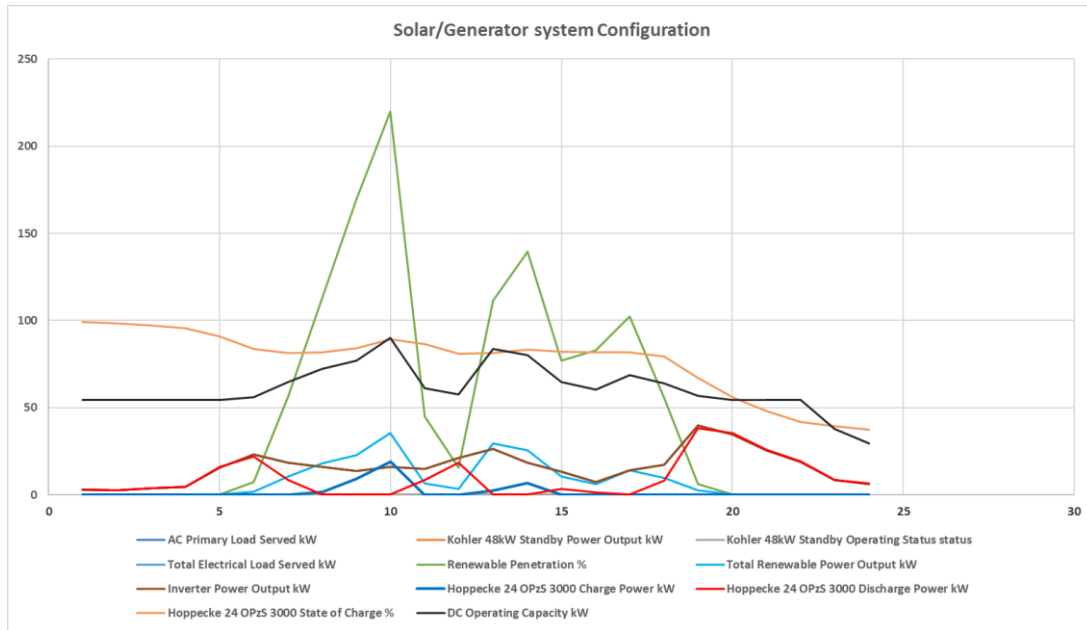
Solar/Generator hybrid micro grid system is sensitive to changes in the price of diesel for the generator. Sensitivity analysis results are shown in **Fig 4.85** below.



**Fig 4.85** Sensitivity analysis results graph

As diesel price increases from R13.00/litre to R14.00/litre and to R15.00/litre, the Operating Cost increases from R436 039 to R436 498 and to R436 864 million respectively. As a result, the COE increases from R4.80 /kWh to R4.82 /kWh and to R 4.83 /kWh respectively. An increase of the COE from a higher value of R4.80 /kWh (USD \$0.32 /kWh) to R4.83 /kWh (USD \$0.32 /kWh) means the cost of energy is becoming more expensive for the consumer.

The Graph of best Optimised *Solar/Generator hybrid micro grid* system configuration is shown in Fig. 4.86 below.



*Fig 4.86 Hourly system performance*

**Fig 4.86** above shows that the renewable fraction, which serves the total load, is very high. The battery bank charges more during daylight hours and discharges mostly at night when the load depends on battery because of absence of sunlight. The Generator is just on standby mode just in case all power supply fails from solar energy.

## Chapter 5: Conclusions and Recommendations

The following conclusions have been drawn from this project. The most technically and economically viable system configuration is Solar/generator micro grid with LCOE of R4.80 /kWh (US \$0.32/kWh). This system configuration is highly preferred because of its lower carbon emissions of 4843 kg/yr greenhouse gas emissions. The most reliable system configuration is the Solar/generator hybrid micro grid. It has only 388 hours per year operation hours of diesel generator, burns 1856 litres of diesel. All four viable hybrid micro grid configurations are more than 90 % renewable and this is a good initiative to curb carbon emissions that pollute the environment and are harmful to life on Earth. The cost of battery backup system, which is R2 448 000.00, contributes over 60% of the entire capital cost of the system and is the most expensive. Economically viable micro grid configuration systems are sensitive to either price of diesel for generator or inflation rates as applicable to the system configuration. The higher diesel price contributed to an increase in Operation and Maintenance

cost and ultimately an increase in cost of energy (COE) and contributed to high cost of buying electricity. Hybridisation in the design of micro grid contributes to the reduction of LCOE and therefore it is the best option for micro grid systems in rural villages in Lesotho. The economic viability of these system configurations was compared against LCOE of R5.00/kWh of solar micro grid at Ha Makebe in Lesotho. Government of Lesotho should promote involvement of Independent Power producers in the construction of micro grids. Furthermore, external funding from investors is needed to construct these micro grids because of the high capital cost that is required.

The following recommendations will greatly promote the use of hybrid micro grids in rural villages in Lesotho. Since, willingness and ability to pay from consumers are key, engagement of these communities is very important and must be done before constructing any micro grid in these rural villages. Furthermore, local communities must be trained so that they can be involved in the operation and maintenance of these hybrid micro grids in the rural villages of Lesotho in order to ensure sustainability and continuity of such projects. Secondly, since currently, there is little data for some rivers in the country, Government of Lesotho should invest in suitable equipment and professionals for collecting flow rates of all rivers and perennial streams for construction of hydro micro grids in the rural areas. Lastly, biomass is recommended to be included in the energy mix for further area of study.

## References

- [1] J. G. P. Balderrama, “Incorporating high-resolution demand and techno-economic optimization to evaluate micro-grids into the Open Source Spatial Electrification Tool (OnSSET),” *Energy for Sustainable Development*, p. 21, 2020.
- [2] Reyaz Ahmed Bafanda, “a case study for optimum sizing and selection of components HRERs based power system.pdf.” 2018.
- [3] Esan Ayodelea, Sanjay Misrab, Robertas Damasevicius, and Rytis Maskeliunase, “A case study comparison between photovoltaic and fossil generation.pdf.” 2019.
- [4] L. Semple, R. Carriveau, and D. S.-K. Ting, “A techno-economic analysis of seasonal thermal energy storage for greenhouse applications,” *Energy and Buildings*, vol. 154, pp. 175–187, Nov. 2017, doi: 10.1016/j.enbuild.2017.08.065.
- [5] M. Mpholo, D. Steuerwald, and T. Kukeera, Eds., *Africa-EU Renewable Energy Research and Innovation Symposium 2018 (RERIS 2018): 23–26 January 2018, National University of Lesotho On occasion of NULISTICE 2018*. Cham: Springer International Publishing, 2018. doi: 10.1007/978-3-319-93438-9.
- [6] Yimin Wang, Mingzhe Zhao, Jianxia Chang and , Xuebin Wang, Yuyu Tian, “Study on the combined operation of a hydro-thermal-wind hybrid power.pdf.” 2019.

- [7] Hussam M. Almukhtar *et al.*, “Feasibility study of achieving reliable electricity supply using hybrid power system for rural primary schools in Iraq A case study with Umm Qasr primary school.” 2019.
- [8] UNDP/GEF, “Report Final Mini-grids Regulatory Requirements FSS\_3.docx.” Mar. 2019.
- [9] V. Suresh, M. M., and R. Kiranmayi, “Modelling and optimization of an off-grid hybrid renewable energy system for electrification in a rural areas,” *Energy Reports*, vol. 6, pp. 594–604, Nov. 2020, doi: 10.1016/j.egyr.2020.01.013.
- [10] Google Earth Pro, “ha lehloara google earth.pdf.” 2021. [Online]. Available: [https://earth.google.com/web/@-28.94842665,28.5589172,2228.2008192a,1048.90355697d,35y,359.99879999h,0t,0r?utm\\_source=earth7&utm\\_campaign=vine&hl=en](https://earth.google.com/web/@-28.94842665,28.5589172,2228.2008192a,1048.90355697d,35y,359.99879999h,0t,0r?utm_source=earth7&utm_campaign=vine&hl=en)
- [11] M. Mpholo, T. Nchaba, and M. Monese, “Yield and performance analysis of the first grid-connected solar farm at Moshoeshoe I International Airport, Lesotho,” *Renewable Energy*, vol. 81, pp. 845–852, Sep. 2015, doi: 10.1016/j.renene.2015.04.001.
- [12] L. Z. Thamae, R. I. Thamae, and T. M. Thamae, “Assessing a decade of regulatory performance for the Lesotho electricity industry,” *Utilities Policy*, vol. 35, pp. 91–101, Aug. 2015, doi: 10.1016/j.jup.2015.07.006.
- [13] LEWA, “Lesotho Electricity and Water Authority.pdf.” Apr. 18, 2019.
- [14] M. Mpholo *et al.*, “Determination of the lifeline electricity tariff for Lesotho,” *Energy Policy*, vol. 140, p. 111381, May 2020, doi: 10.1016/j.enpol.2020.111381.
- [15] Phyu Phyu Win, Zin Mar, “Performance Analysis of Autonomous Hybrid Distributed Generation Based on Typical Control Strategies for Rural Electrification in Myanmar.pdf.” 2019.
- [16] Hossein Shahinzadeh, Gevork B. Gharehpetian, S. Hamid Fathi, Sayed Mohsen NasrAzadani, “Optimal Planning of an Off-grid Electricity Generation with Renewable Energy Resources using the HOMER Software.” 2015.
- [17] B M Taele, L Mokhutsoane, and Himanshu Narayan, “Solar energy resources potential and sustainable production of biomass energy in Lesotho,” 2010, doi: 10.13140/RG.2.1.2962.0882.
- [18] S. Phrakonkhama, G. Remya, , D. Dialloa, and , C. Marchanda, “Pico vs Micro Hydro based Optimized Sizing of a Centralized.pdf.” 2012.
- [19] Imdadullah, “Optimal Hybrid Energy System for Rural Electrification in India using HOMER Software .pdf.” 2017.
- [20] K. J. Hancock, “The expanding horizon of renewable energy in sub-Saharan Africa: Leading research in the social sciences,” *Energy Research & Social Science*, vol. 5, pp. 1–8, Jan. 2015, doi: 10.1016/j.erss.2014.12.021.
- [21] D. Holm, “Renewables in Africa,” p. 2, 2009.
- [22] “se4all-rapid-assessment-gap-analysis-1532183674.pdf.”
- [23] Theophilus Nii Odai Mensah\* and , Ayobami Solomon Oyewo, Christian Breyer, “The role of biomass in sub-Saharan Africa.pdf.” 2021.
- [24] Priyanka Jha, and , Stefan Schmidt, “State of biofuel development in sub-Saharan Africa How far sustainable.pdf.” 2021.
- [25] Department of Energy, “scaling-up-renewable-energy-for-low-income-countries-sreplesotho-investment-plan-1544093189.pdf.” 2017.
- [26] Adam Hirscha, , Yael Paraga, and , Josep Guerrero, “Microgrids A review of technologies, key drivers, and outstanding issues.pdf,” 2018.

- [27] Sijia Geng, Maria Vrakopoulou, and Ian A. Hiskens, “Chance-constrained optimal capacity design for a renewable-only islanded microgrid.pdf.” 2020.
- [28] A. Cagnano, E. De Tugliea, and P. Mancarella, “Microgrids Overview and guidelines for practical implementations and operation.pdf.” 2020.
- [29] Sarah Newman, *et al.*, “A comparison of PV resource modeling for sizing microgrid.pdf.” 2020.
- [30] Andrés Julián Aristizábal\*, Jorge Herrera, Mónica Castaneda, Sebastian Zapata, Daniel, Ospinab, and Edison Banguero, “A new methodology to model and simulate microgrids operating in low latitude countries.pdf.” 2019.
- [31] Marlon Huamani Bellido, Luiz Pinguelli Rosa, Amaro Olímpio Pereira, Djalma Mosqueira Falcao, and Suzana Kahn Ribeiro, “Barriers challenges and opportunities for microgrid implementation.pdf.” 2018.
- [32] P. A. Nguyen, M. Abbott, and T. L. T. Nguyen, “The development and cost of renewable energy resources in Vietnam,” *Utilities Policy*, vol. 57, pp. 59–66, Apr. 2019, doi: 10.1016/j.jup.2019.01.009.
- [33] M. H. Baloch *et al.*, “Hybrid energy sources status of Pakistan: An optimal technical proposal to solve the power crises issues,” *Energy Strategy Reviews*, vol. 24, pp. 132–153, Apr. 2019, doi: 10.1016/j.esr.2019.02.001.
- [34] Md Alamgir Hossain, Hemanshu Roy Pota, Md Jahangir Hossain, and Frede Blaabjerg, “Evolution of microgrids with converter-interfaced generations Challenges and opportunities.pdf.”
- [35] J. K. Kaldellis, “The contribution of small hydro power stations to the electricity generation in Greece: Technical and economic considerations,” *Energy Policy*, vol. 35, no. 4, pp. 2187–2196, Apr. 2007, doi: 10.1016/j.enpol.2006.06.021.
- [36] A. K. Sharma and N. S. Thakur, “Analyze the factors effecting the development of hydro power projects in hydro rich regions of India,” *Perspectives in Science*, vol. 8, pp. 406–408, Sep. 2016, doi: 10.1016/j.pisc.2016.04.090.
- [37] N. F. Yah, A. N. Oumer, and M. S. Idris, “Small scale hydro-power as a source of renewable energy in Malaysia: A review,” *Renewable and Sustainable Energy Reviews*, vol. 72, pp. 228–239, May 2017, doi: 10.1016/j.rser.2017.01.068.
- [38] S. P. Adhau, “Mini-hydro power generation on existing irrigation projects Case study of Indian sites,” *Renewable and Sustainable Energy Reviews*, p. 11, 2012.
- [39] B. M. Taele, L. Mokhutšoane, and I. Hapazari, “An overview of small hydropower development in Lesotho: Challenges and prospects,” *Renewable Energy*, vol. 44, pp. 448–452, Aug. 2012, doi: 10.1016/j.renene.2012.01.086.
- [40] D. Adu, J. Zhang, Y. Fang, L. Suoming, and R. O. Darko, “A Case Study of Status and Potential of Small Hydro-Power Plants in Southern African Development Community,” *Energy Procedia*, vol. 141, pp. 352–359, Dec. 2017, doi: 10.1016/j.egypro.2017.11.042.
- [41] S. J. Williamson, B. H. Stark, and J. D. Booker, “Low Head Pico Hydro Turbine Selection using a Multi-Criteria Analysis,” p. 107.
- [42] M. Johansson and T. O’Doherty, “Feasibility of Micro-Hydro Schemes in South Glamorgan, Wales,” *Energy Procedia*, vol. 142, pp. 309–314, Dec. 2017, doi: 10.1016/j.egypro.2017.12.049.
- [43] S. W. D. Turner, M. Hejazi, S. H. Kim, L. Clarke, and J. Edmonds, “Climate impacts on hydropower and consequences for global electricity supply investment needs,” *Energy*, vol. 141, pp. 2081–2090, Dec. 2017, doi: 10.1016/j.energy.2017.11.089.

- [44] B. A. Nasir, "Design Considerations of Micro-hydro-electric Power Plant," *Energy Procedia*, vol. 50, pp. 19–29, 2014, doi: 10.1016/j.egypro.2014.06.003.
- [45] W. Uddin *et al.*, "Current and future prospects of small hydro power in Pakistan: A survey," *Energy Strategy Reviews*, vol. 24, pp. 166–177, Apr. 2019, doi: 10.1016/j.esr.2019.03.002.
- [46] E. Gallego, A. Rubio-Clemente, J. Pineda, L. Velásquez, and E. Chica, "Experimental analysis on the performance of a pico-hydro Turgo turbine," *Journal of King Saud University - Engineering Sciences*, p. S1018363920302300, May 2020, doi: 10.1016/j.jksues.2020.04.011.
- [47] M. K. Mishra, N. Khare, and A. B. Agrawal, "Small hydro power in India: Current status and future perspectives," *Renewable and Sustainable Energy Reviews*, vol. 51, pp. 101–115, Nov. 2015, doi: 10.1016/j.rser.2015.05.075.
- [48] M. Kamran, "Designing and economic aspects of run-of-canal based micro-hydro system on Balloki-Sulaimanki Link Canal-I for remote villages in Punjab, Pakistan," *Renewable Energy*, p. 12, 2019.
- [49] P. Punys, A. Kvaraciejus, A. Dumbrasukas, L. Šilinis, and B. Popa, "An assessment of micro-hydropower potential at historic watermill, weir, and non-powered dam sites in selected EU countries," *Renewable Energy*, vol. 133, pp. 1108–1123, Apr. 2019, doi: 10.1016/j.renene.2018.10.086.
- [50] Y. Itani, M. R. Soliman, and M. Kahil, "Recovering energy by hydro-turbines application in water transmission pipelines: A case study west of Saudi Arabia," *Energy*, vol. 211, p. 118613, Nov. 2020, doi: 10.1016/j.energy.2020.118613.
- [51] *iea*, "iea\_org\_reports\_world\_energy\_balances\_overview\_world.pdf." Jul. 2020.
- [52] <https://www.simscale.com/docs/analysis-types/convective-heat-transferanalysis/direct-and-diffused-radiation/>,  
"www\_simscale\_com\_docs\_analysis\_types\_convective\_heat\_transfe.pdf."
- [53] S. Lou, Y. Huang, D. H. W. Li, D. Xia, X. Zhou, and Y. Zhao, "Optimizing the beam and sky diffuse radiation calculations under random obstructions of urban environments," *Building and Environment*, vol. 196, p. 107806, Jun. 2021, doi: 10.1016/j.buildenv.2021.107806.
- [54] J. A. Duffie and W. A. Beckman, "Solar Engineering of Thermal Processes," p. 928.
- [55] C. S. Lai, X. Li, L. L. Lai, and M. D. McCulloch, "Daily clearness index profiles and weather conditions studies for photovoltaic systems," *Energy Procedia*, vol. 142, pp. 77–82, Dec. 2017, doi: 10.1016/j.egypro.2017.12.013.
- [56] C. Magarreiro, M. C. Brito, and P. M. M. Soares, "Assessment of diffuse radiation models for cloudy atmospheric conditions in the Azores region," *Solar Energy*, vol. 108, pp. 538–547, Oct. 2014, doi: 10.1016/j.solener.2014.08.003.
- [57] C. Phurailatpam, B. S. Rajpurohit, and L. Wang, "Planning and optimization of autonomous DC microgrids for rural and urban applications in India," *Renewable and Sustainable Energy Reviews*, vol. 82, pp. 194–204, Feb. 2018, doi: 10.1016/j.rser.2017.09.022.
- [58] J. Chantana, Y. Imai, Y. Kawano, Y. Hishikawa, K. Nishioka, and T. Minemoto, "Impact of average photon energy on spectral gain and loss of various-type PV technologies at different locations," *Renewable Energy*, vol. 145, pp. 1317–1324, Jan. 2020, doi: 10.1016/j.renene.2019.06.139.
- [59] E. Lorenzo, "Solar Electricity: Engineering of Photovoltaic Systems," 1994, p. 4.

- [60] S. Sarikh, M. Raoufi, A. Bennouna, A. Benlarabi, and B. Ikken, "Implementation of a plug and play I-V curve tracer dedicated to characterization and diagnosis of PV modules under real operating conditions," *Energy Conversion and Management*, vol. 209, p. 112613, Apr. 2020, doi: 10.1016/j.enconman.2020.112613.
- [61] P. Pal, V. Mukherjee, P. Kumar, and M. E. Makhatha, "Pre-feasibility analysis and performance assessment of solar photovoltaic (PV) modules for the application of renewable power generation," *Materials Today: Proceedings*, vol. 39, pp. 1813–1819, 2021, doi: 10.1016/j.matpr.2020.10.557.
- [62] Y. S. Mohammed, M. W. Mustafa, and N. Bashir, "Status of renewable energy consumption and developmental challenges in Sub-Sahara Africa," *Renewable and Sustainable Energy Reviews*, vol. 27, pp. 453–463, Nov. 2013, doi: 10.1016/j.rser.2013.06.044.
- [63] B. P. Singh, S. K. Goyal, and P. Kumar, "Solar PV cell materials and technologies: Analyzing the recent developments," *Materials Today: Proceedings*, p. S2214785321000146, Feb. 2021, doi: 10.1016/j.matpr.2021.01.003.
- [64] A. Bouraiou, M. Hamouda, A. Chaker, M. Sadok, M. Mostefaoui, and S. Lachtar, "Modeling and Simulation of Photovoltaic Module and Array Based on One and Two Diode Model Using Matlab/Simulink," *Energy Procedia*, vol. 74, pp. 864–877, Aug. 2015, doi: 10.1016/j.egypro.2015.07.822.
- [65] A. K. Abdulrazzaq, G. Bognár, and B. Plesz, "Accurate method for PV solar cells and modules parameters extraction using I–V curves," p. 11.
- [66] L. Wang, J. Liu, and F. Qian, "Wind speed frequency distribution modeling and wind energy resource assessment based on polynomial regression model," *International Journal of Electrical Power & Energy Systems*, vol. 130, p. 106964, Sep. 2021, doi: 10.1016/j.ijepes.2021.106964.
- [67] Y. Gao *et al.*, "Assessing the wind energy potential of China in considering its variability/intermittency," *Energy Conversion and Management*, vol. 226, p. 113580, Dec. 2020, doi: 10.1016/j.enconman.2020.113580.
- [68] A. Kudelin and V. Kutcherov, "Wind ENERGY in Russia: The current state and development trends," *Energy Strategy Reviews*, vol. 34, p. 100627, Mar. 2021, doi: 10.1016/j.esr.2021.100627.
- [69] P. Sadorsky, "Wind energy for sustainable development: Driving factors and future outlook," *Journal of Cleaner Production*, vol. 289, p. 125779, Mar. 2021, doi: 10.1016/j.jclepro.2020.125779.
- [70] L. Grau, C. Jung, and D. Schindler, "Sounding out the repowering potential of wind energy – A scenario-based assessment from Germany," *Journal of Cleaner Production*, vol. 293, p. 126094, Apr. 2021, doi: 10.1016/j.jclepro.2021.126094.
- [71] S. M. Weekes and A. S. Tomlin, "Data efficient measure-correlate-predict approaches to wind resource assessment for small-scale wind energy," *Renewable Energy*, vol. 63, pp. 162–171, Mar. 2014, doi: 10.1016/j.renene.2013.08.033.
- [72] D. Nong, C. Wang, and A. Q. Al-Amin, "A critical review of energy resources, policies and scientific studies towards a cleaner and more sustainable economy in Vietnam," *Renewable and Sustainable Energy Reviews*, vol. 134, p. 110117, Dec. 2020, doi: 10.1016/j.rser.2020.110117.
- [73] Z. Ren, Z. Wang, F. Wang, S. Li, and Z. L. Wang, "Vibration behavior and excitation mechanism of ultra-stretchable triboelectric nanogenerator for wind energy harvesting," *Extreme Mechanics Letters*, vol. 45, p. 101285, May 2021, doi:

- 10.1016/j.eml.2021.101285.
- [74] H. Solman, M. Smits, B. van Vliet, and S. Bush, “Co-production in the wind energy sector: A systematic literature review of public engagement beyond invited stakeholder participation,” *Energy Research & Social Science*, vol. 72, p. 101876, Feb. 2021, doi: 10.1016/j.erss.2020.101876.
- [75] B. R. Karthikeya, P. S. Negi, and N. Srikanth, “Wind resource assessment for urban renewable energy application in Singapore,” *Renewable Energy*, vol. 87, pp. 403–414, Mar. 2016, doi: 10.1016/j.renene.2015.10.010.
- [76] M. N. Ambia, A. Al-Durra, C. Caruana, and S. M. Muyeen, “Power management of hybrid micro-grid system by a generic centralized supervisory control scheme,” *Sustainable Energy Technologies and Assessments*, vol. 8, pp. 57–65, Dec. 2014, doi: 10.1016/j.seta.2014.07.003.
- [77] G. Bekele and G. Tadesse, “Feasibility study of small Hydro/PV/Wind hybrid system for off-grid rural electrification in Ethiopia,” *Applied Energy*, vol. 97, pp. 5–15, Sep. 2012, doi: 10.1016/j.apenergy.2011.11.059.
- [78] A. Derrouazin, N. Mekakia-Maaza, R. Taleb, M. Nacef, and M. Aillerie, “Low Cost Hybrid Energiess Smart Management System Applied for Micro-grids,” *Energy Procedia*, vol. 50, pp. 729–737, 2014, doi: 10.1016/j.egypro.2014.06.090.
- [79] B. Bhandari, K.-T. Lee, C. S. Lee, C.-K. Song, R. K. Maskey, and S.-H. Ahn, “A novel off-grid hybrid power system comprised of solar photovoltaic, wind, and hydro energy sources,” *Applied Energy*, vol. 133, pp. 236–242, Nov. 2014, doi: 10.1016/j.apenergy.2014.07.033.
- [80] F. K. Abo-Elyousr and A. Elnozahy, “Bi-objective economic feasibility of hybrid micro-grid systems with multiple fuel options for islanded areas in Egypt,” *Renewable Energy*, vol. 128, pp. 37–56, Dec. 2018, doi: 10.1016/j.renene.2018.05.066.
- [81] M. H. Amrollahi and S. M. T. Bathaee, “Techno-economic optimization of hybrid photovoltaic/wind generation together with energy storage system in a stand-alone micro-grid subjected to demand response,” *Applied Energy*, vol. 202, pp. 66–77, Sep. 2017, doi: 10.1016/j.apenergy.2017.05.116.
- [82] L. Olatomiwa, S. Mekhilef, A. S. N. Huda, and O. S. Ohunakin, “Economic evaluation of hybrid energy systems for rural electrification in six geo-political zones of Nigeria,” *Renewable Energy*, vol. 83, pp. 435–446, Nov. 2015, doi: 10.1016/j.renene.2015.04.057.
- [83] Z. Girma, “Hybrid renewable energy design for rural electrification in Ethiopia,” p. 16, 2013.
- [84] B. I. Ouedraogo, S. Kouame, Y. Azoumah, and D. Yamegueu, “Incentives for rural off grid electrification in Burkina Faso using LCOE,” *Renewable Energy*, vol. 78, pp. 573–582, Jun. 2015, doi: 10.1016/j.renene.2015.01.044.
- [85] M. L. Kolhe, “Techno-economic sizing of off-grid hybrid renewable energy system for rural electrification in Sri Lanka,” *Sustainable Energy Technologies and Assessments*, p. 12, 2015.
- [86] HOMER, “HOMER2\_2.8\_HelpManual.pdf.” 2015.
- [87] S. Bhakta and V. Mukherjee, “Solar potential assessment and performance indices analysis of photovoltaic generator for isolated Lakshadweep island of India,” *Sustainable Energy Technologies and Assessments*, vol. 17, pp. 1–10, Oct. 2016, doi: 10.1016/j.seta.2016.07.002.

- [88] E. N. Nyeche, “Modelling and optimisation of a hybrid PV-wind turbine-pumped hydro storage energy system for mini-grid application in coastline communities,” *Journal of Cleaner Production*, p. 12, 2020.
- [89] M. Müller, R. Bründlinger, O. Arz, W. Miller, J. Schulz, and G. Lauss, “PV-off-grid Hybrid Systems and MPPT Charge Controllers, a State of the Art Analyses,” *Energy Procedia*, vol. 57, pp. 1421–1430, 2014, doi: 10.1016/j.egypro.2014.10.133.
- [90] U. Yilmaz, A. Kircay, and S. Borekci, “PV system fuzzy logic MPPT method and PI control as a charge controller,” *Renewable and Sustainable Energy Reviews*, vol. 81, pp. 994–1001, Jan. 2018, doi: 10.1016/j.rser.2017.08.048.
- [91] H. R. E.-H. Bouchekara, M. S. Javaid, Y. A. Shaaban, M. S. Shahriar, M. A. M. Ramli, and Y. Latreche, “Decomposition based multiobjective evolutionary algorithm for PV/Wind/Diesel Hybrid Microgrid System design considering load uncertainty,” *Energy Reports*, vol. 7, pp. 52–69, Nov. 2021, doi: 10.1016/j.egy.2020.11.102.
- [92] J. Li, P. Liu, and Z. Li, “Optimal design and techno-economic analysis of a solar-windbiomass off-grid hybrid power system for remote rural electrification: A case study of west China,” *Energy*, vol. 208, p. 118387, Oct. 2020, doi: 10.1016/j.energy.2020.118387.
- [93] T. Ma and M. S. Javed, “Integrated sizing of hybrid PV-wind-battery system for remote island considering the saturation of each renewable energy resource,” *Energy Conversion and Management*, vol. 182, pp. 178–190, Feb. 2019, doi: 10.1016/j.enconman.2018.12.059.
- [94] Central Bank of Lesoto, “Dec\_2019\_MEO\_CBL.pdf.” 2021 2019.
- [95] Department of Rural Water Supply, “Department of rural water supply.pdf.” 2021. [Online]. Available: <https://drws.gov.ls/portal/apps/sites/#/lesothowater>
- [96] T. Hove and H. Tazvinga, “A techno-economic model for optimising component sizing and energy dispatch strategy for PV-diesel-battery hybrid power systems,” *J. energy South. Afr.*, vol. 23, no. 4, pp. 18–28, Nov. 2012, doi: 10.17159/24133051/2012/v23i4a3175.
- [97] Chengdu Forster Technology Co.Ltd., “100 kw francis hydro turbine.pdf.”
- [98] “Kohler 48RCLB - 48 kW Emergency Standby Power Generator 120/240V SinglePhase,” *eComfort*. <https://www.ecomfort.com/Kohler-48RCLB/p92616.html> (accessed Apr. 26, 2021).
- [99] alibaba, “www\_alibaba\_com\_product\_detail\_Export\_Jinko\_300W\_Solar\_Panel.pdf.” 2021.
- [100] “Renewable power generation costs in 2019,” p. 144.
- [101] Eagle PERC 60 280-300 W.pdf, “Eagle PERC 60 280-300 W.pdf.”
- [102] Western co, “www\_alibaba\_com\_product\_detail\_High\_Quality\_MPPT\_Charge\_cont.pdf.” 2021.
- [103] F. Symo, “Solar inverter » Fronius » Fronius Symo,” p. 4.
- [104] fronius, “fronius-solar-three-phase-3kw-20kw-string-inverter-symo-series-datasheetindia.pdf.”
- [105] Biotechx, “www\_biotechx\_com\_Product\_24\_OPzS\_3000\_327\_htm.pdf.” 2021.
- [106] Shenzhen Sunnyway Battery Tech Co.Ltd, “24opzs3000-2V3000Ah.pdf.”
- [107] One Power, “OnePowerHaMakebe.pdf.”
- [108] “AWS HC Wind Turbines | Australian Wind and Solar,” *Aus Wind and Solar*. <https://www.australianwindandsolar.com/aws-hc-wind-turbines> (accessed Apr. 26, 2021).

- [109] “[Hot Item] 20kw Radial in Pipe Hydro Turbine Water Turbine for Mountain Area,” *Made-in-China.com*. <https://xindaenergy.en.made-inchina.com/product/uyHmgDGvbLcs/China-20kw-Radial-in-Pipe-Hydro-TurbineWater-Turbine-for-Mountain-Area.html> (accessed Apr. 26, 2021).
- [110] S. K. Singal, R. P. Saini, and C. S. Raghuvanshi, “Analysis for cost estimation of low head run-of-river small hydropower schemes,” *Energy for Sustainable Development*, vol. 14, no. 2, pp. 117–126, Jun. 2010, doi: 10.1016/j.esd.2010.04.001.
- [111] “IRENA\_mini-grid\_policies\_2018.pdf.” [https://www.irena.org/media/Files/IRENA/Agency/Publication/2018/Oct/IRENA\\_minigrd\\_policies\\_2018.pdf](https://www.irena.org/media/Files/IRENA/Agency/Publication/2018/Oct/IRENA_minigrd_policies_2018.pdf) (accessed Mar. 16, 2019).
- [112] Emília Inês Come Zebra, , Henny J. van der Windt, , Geraldo Nhumaio, and , Andr’e P.C. Faaij, “A review of hybrid renewable energy systems in mini-grids for off-grid electrification in developing countries.” 2021.