

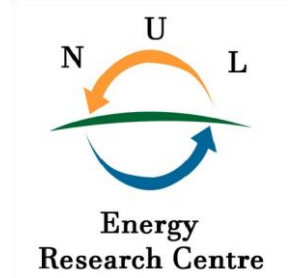

**National University of Lesotho**



# **Rehabilitation of Katse Dam Mini-Hydropower Plant**

*Ntoampe W. Thamae*

A dissertation submitted in partial fulfilment  
of the requirements for the degree of

***Master of Science in Sustainable Energy***

Offered by the

**Energy Research Centre**

Faculty of Science & Technology April 2022

## **Acknowledgements**

I wish to extend my gratitude to Dr. Molefe Makhele and Dr. Liphapang Khaba for their extraordinary efforts in supervising this study. It was a great pleasure to have them throughout this hectic task.

I would also like to acknowledge my family for their consistent and unwavering support. Lastly, I would like to acknowledge LHDA Authorities for granting me the opportunity to undertake this study.

## **Abstract**

The Katse Dam Mini-Hydropower station was designed to generate and supply electricity to auxiliary systems without connecting to the grid. This would increase the dam power supply and reliability thereby reducing the electricity bill incurred on the Lesotho Highland Water Project (LHWP) for operations. However, to date, the Mini-Hydropower station is not fully operational.

In this study, the decommissioned Katse Dam Mini-Hydropower plant's rehabilitation is evaluated. Three significant activities characterized this rehabilitation process. The upgrading of electro-mechanical equipment or damaged parts, using condition assessment filters. Upgrading is explored by flow duration plots for the possibility of increasing plant capacity. Lastly, the capacity dispatch (Integration) is studied intensively with computer software package (DigSilent Power Factory), for grid integration alternatives. In general, electrical equipment is the plant's most vulnerable to fatigue. Mechanical equipment is moderately damaged, with governor and guide bearing systems standing out.

Assessment of the potential of the plant's capacity increase revealed that the reservoir compensation flow regime resulted in minimum design values of head and discharge being fulfilled 96% of the time. The Katse Dam load capacity is met 90% of the time, while the maximum single machine power is exceeded 84% of the time.

The Mini-Hydropower stable response to dam load growth and decline without a grid was shown in the grid integration option. However, there was a substantial deviation to a sudden loss of grid without load shedding, and the local bus voltage dropped below 6% tolerance.

The findings of this investigation demonstrated the need for this plant to be rehabilitated. All the necessary tests on relevant components point to the goals of the plant and the necessity for restoration. According to the economic study, implementing this project will result in a 9year return on investment and a 2.02 MWh annual energy guarantee, which is 54% of the yearly energy consumption of the auxiliary systems.

# Contents

<b>Abstract</b> .....	i
<b>Contents</b> .....	ii
<b>List of Tables</b> .....	v
<b>List of Figures</b> .....	v
<b>List of Abbreviations and Acronyms</b> .....	vi
<b>Chapter 1: Introduction</b> .....	1
<b>1.1 Background to the study</b> .....	1
<b>1.2 Problem Statement</b> .....	2
<b>1.3 Objectives of the study</b> .....	3
<b>1.4 Research questions</b> .....	3
<b>1.5 Significance of the study</b> .....	3
<b>1.6 Limitations/scope of the study</b> .....	4
<b>1.7 Summary of the methods used in the study</b> .....	4
<b>1.8 Organization of chapters</b> .....	5
<b>Chapter 2: Literature review</b> .....	7
<b>2.1 Rehabilitation</b> .....	7
<b>2.2 A need for rehabilitation</b> .....	7
2.2.1 Upgrading .....	8
2.2.2 Uprating .....	8
<b>2.3 Classification of equipment for rehabilitation</b> .....	8
<b>2.4 Factors affecting rehabilitation of hydropower</b> .....	8
2.4.1 Age and operating conditions.....	9
<b>2.5 Predictors of rehabilitation of hydropower plants</b> .....	10
2.5.1 Hydro Asset Trigger Age (HAT) .....	11
2.5.2 Visual Inspection (VI) .....	11
2.5.3 Equipment Testing (ET).....	12
2.5.4 Equipment Instrumentation (EI).....	13
<b>2.6 Uprating and Grid Integration</b> .....	13
2.6.1 Methods employed for uprating .....	14
2.6.2 The possibility of uprating .....	14
2.6.3 Power system stability classification .....	15

<b>2.7 Project Economic Analysis</b> .....	16
<b>Chapter 3: Methodology</b> .....	17
<b>3.1 Condition Assessment</b> .....	17
<b>3.2 Hydrological Assessment</b> .....	17
<b>3.3 Stability Assessment</b> .....	18
<b>3.4 Rehabilitation Methods</b> .....	18
3.4.1 Condition assessment of components .....	18
3.4.2 Hydro asset trigger age of components .....	19
3.4.3 Visual Inspection of components .....	20
3.4.4 Equipment operational tests .....	22
3.4.5 Equipment Instrumentation .....	24
3.4.6 Condition assessment filter scale .....	24
<b>3.5 Hydrological assessment</b> .....	25
<b>3.6 Network stability assessment</b> .....	26
<b>3.7 Project Economic Appraisal</b> .....	26
<b>Chapter 4: Results and Discussions</b> .....	28
<b>4.1 Results Condition assessment filter</b> .....	28
4.1.1 The hydro asset trigger age (HAT) .....	28
4.1.2 Visual inspection .....	29
4.1.3 Equipment testing .....	30
4.1.4 Instrumentation.....	34
4.1.5 Condition Assessment Filter .....	34
<b>4.2 Results: Resource Assessment</b> .....	36
4.2.1 Discharge duration assurance .....	37
4.2.2 Head Duration Assurance .....	37
4.2.3 Power duration assurance .....	38
4.2.4 Summary: Resource assessment .....	40
<b>4.3 Stability assessment</b> .....	40
4.3.1 Mini-Hydropower (1 unit) response to switching event (dam load only) .....	41

4.3.2 Mini-Hydropower (1 unit) response to grid loss switching event (dam and camp load) ...	42
4.3.3 Mini-Hydropower (2 units) response to switching event (dam and camp load).....	43
4.3.4 Mini-Hydropower (1 unit) response to load increase and decrease (dam only).....	44
4.3.5 Mini-Hydropower (2 units) response to load increase and decrease (dam & camp) .....	46
<b>4.4 Project Economic Appraisal .....</b>	<b>48</b>
4.4.1 Capital Cost.....	49
4.4.2 Electro – Mechanical components .....	49
4.4.3 Economic Analysis.....	50
4.4.4 Project Economic Viability .....	51
<b>4.5 Results Validation.....</b>	<b>52</b>
<b>4.6 Summary.....</b>	<b>52</b>
<b>Chapter 5: Conclusion and Recommendations.....</b>	<b>54</b>
5.1. Conclusion .....	54
5.2. Recommendations .....	56
<b>References.....</b>	<b>58</b>

## List of Tables

<b>Table 1:</b> Rapid Assessment Rating [35], [82].....	20
<b>Table 2:</b> Physical and Structural Condition Assessment Sheet [35].....	21
<b>Table 3:</b> Hydropower Electro-Mechanical Components, Parts, and Possible Problems as identified [18], [35], [83].....	22
<b>Table 4:</b> Dielectric Absorption Ratio Recommended Values [84], [88].....	23
<b>Table 5:</b> Polarization Index Recommended Values [84], [88].....	23
<b>Table 6:</b> Condition Assessment Filter Rating Scale.....	25
<b>Table 7:</b> Katse Dam Mini-Hydropower Plant Equipment Rapid Assessment Rating.....	29
<b>Table 8:</b> Katse Dam Mini-Hydropower Plant Equipment Physical and Structural Condition Assessment.....	30
<b>Table 9:</b> Stator Winding Measured Average Values IR, PI, DAR, and Calculated PI.....	31
<b>Table 10:</b> Rotor Winding Measured Average Values IR, PI, DAR and Calculated IR.....	31
<b>Table 11:</b> Generator Result Summary and Rating.....	32
<b>Table 12:</b> Primary Side Winding Measured Average Values IR, PI, DAR and Calculated PI.....	32
<b>Table 13:</b> Secondary Side Measured Average Values IR, PI, DAR and Calculated PI.....	32
<b>Table 14:</b> Transformer Result Summary and Rating.....	33
<b>Table 15:</b> Governor Hydraulic System Oil Test Results.....	33
<b>Table 16:</b> Guide Bearings and Generator Gearbox Hydraulic System Oil Test Results.....	34
<b>Table 17:</b> Katse Dam Mini-Hydropower Plant Components Instrumentation Results.....	34
<b>Table 18:</b> Katse Dam Mini-Hydropower Plant Equipment Condition Assessment Filter and Rating.....	35
<b>Table 19:</b> Katse Dam Compensation System Hydrological Resources Summary.....	40
<b>Table 20:</b> Katse Dam Mini-Hydropower Plant Installation Costs 2022.....	49
<b>Table 21:</b> Katse Dam Economic Analysis Summary.....	51

## List of Figures

<b>Figure 1:</b> Process flow diagram for Condition Assessment of components [13].....	17
<b>Figure 2:</b> Katse Dam Mini Hydro Plant Condition Assessment Rating Graph.....	34

**Figure 3:** Katse Dam Compensation System Discharge versus Assurance for the period 1995-2021.....35

**Figure 4:** Katse Dam compensation System Head versus Assurance for the period 1995-2021.....36

**Figure 5:** Katse Dam compensation system Power Potential, Discharge versus Assurance 1995-2021.....36

**Figure 6:** Katse Dam Compensation System Power Potential, Head versus Assurance for the period 1995-2021.....37

**Figure 7:** Katse Dam compensation system Power Potential versus Assurance for the period 1995-2021.....37

**Figure 8:** Katse Dam Network Model.....49

**Figure 9:** Single Machine Mini-Hydropower Response on Dam Load Only.....50

**Figure 10:** Single Machine Mini-Hydropower Response on Dam and Camp Load.....51

**Figure 11:** Two Machines Mini-Hydropower Response \_Load Dam + Camp.....51

**Figure 12:** Single Machine Response with Dam Load increasing in 3 seconds.....52

**Figure 13:** Single Machine Response with Dam Load decreasing in 3 seconds.....52

**Figure 14:** Two Mini-Hydropower units Response with Dam and Camp Load and Grid Synchronising within 3sec and Load increase in 3.5 sec.....53

**Figure 15:** 2 MH Response with Dam and Camp Load and Grid Synchronising within 3sec and Load increase in 3.5 sec.....53

## List of Abbreviations and Acronyms

<b>Abbreviation Meaning</b>		<b>Page</b>
AI	Annual Inspection	20
ASTM	American Society for Testing and Materials	11
AVR	Automatic Voltage Regulation	21
CB	Circuit Breaker	28
CPI	Consumer Price Index	46

DAR	dielectric absorption ratio	21
DGA	Dissolved Gas Analysis	12
EI	Equipment Instrumentation	12
ET	Equipment Testing	11
FV	Future Value	46
HAT	Hydropower Assessment Tool	9
Hn	Net head	38
Hn Min	Minimum net head	38
Hnrated	Rated net head	38
iCAP (ICP-OES) Spectrometry	Thermo Scientific -Inductively Coupled Plasma-Optical Emission Spectrometry	11
IEC	International Electrotechnical Commission	11
IEEE	Institute of Electrical and Electronics Engineers	11
IFR	Instream Low Requirements	24
IR	Insulation Resistance	28
ISO	International Organization for Standardization	11
KOL	Kingdom of Lesotho	1
LEC	Lesotho Electricity Company	2
LHDA	Lesotho Highlands Development Authority	3
LHWP	Lesotho Highlands Water Project	1
MASL	Metres Above Sea Level	1
MIT	Megger Insulation Resistance Tester	28
MO	Machine Overhaul	20
PD	Partial Discharges	12
PI	Polarization index	21
PQ	Particle Quantifier	31
Prated	Rated Power	38
PSI	Pounds per square inch	32
pu	Per unit	40

PV	Present Value	46
Qd	Design discharge	38
Qmin	Minimum discharge	38
Qrated	Rated discharge	38
RSA	Republic of South Africa	1
SDG	Sustainable Development Goal	4
TCTA	Trans Caledon Tunnel Authority	3
TPAR	Three pole auto reclose	50
UHF	Ultra-High Frequency	12
UN	United Nations	53
USD	United States of America Dollar	48
VI	Visual Inspection	10
WSE	Water Surface Elevation	24

## **Chapter 1: Introduction**

In this chapter, a brief background on Katse Dam Mini-Hydropower is outlined. The shortcomings of the current operation section of Mini-Hydropower are addressed; and therefore, the objectives of this study are formulated. Then the scope of the intended work to achieve the stipulated objectives, and how they were integrated to improve the plant capacity is outlined. Lastly, this chapter presents the summary of the subsequent chapters.

### **1.1 Background to the study**

Katse Dam, within which the Mini-Hydropower which is the subject of this study was constructed, was built as part of the Phase I of the Lesotho Highlands Water Project (LHWP). The LHWP is a multi-phase bi-national project of the Kingdom of Lesotho (KOL) and the Republic of South Africa (RSA) meant for the mutual benefit of both countries [1]-[2]. LHWP is aimed at harnessing the water resources of the highlands of Lesotho in order to transfer water to South Africa and generate electricity for Lesotho [1]. Katse Dam is located about 2 km downstream of the confluence of the Bokong and Malibamatšo Rivers. The dam serves as the main reservoir for the LHWP Scheme [1].

Approximately 10% of the Malibamatšo River inflows into Katse Reservoir have been designated for compensation downstream of the dam in order to maintain the minimum river flows required by environmental regulations [3]. In an effort to increase electricity generation capacity and to take advantage of the compensation flows, the Katse Mini-Hydropower station was constructed [1], [4]. The Mini-Hydropower plant was designed to generate and supply electricity to the Katse Dam auxiliary systems without connecting to the national grid [5]. The operational off-grid Mini-Hydropower reduces the amount of electricity that is drawn from the national grid, and also increases the dam power supply security and reliability. This therefore reduces the electricity bill incurred by the LHWP for its operations.

The compensating discharge system, which consists of four penstock intakes at various altitudes and three downstream manifold discharge outlets, was used to design the MiniHydropower station. The elevations of the inlet penstocks are 2033.60 meters above sea level (m.a.s.l), 2018.10 m.a.s.l, 2002.60 m.a.s.l, and 1987.10 m.a.s.l, respectively [6]. One outlet, dedicated just for compensation releases, is at elevation 1932.4 m.a.s.l [6]. The other two outlets at the Mini-Hydropower station are at elevation 1899 m.a.s.l. The maximum design working level of Katse Dam is 2053 m.a.s.l., with a gross head of roughly 154 meters [6], [5].

One of the Mini-Hydropower station's outlets is currently blanked out, thus remaining available for future Mini-Hydropower expansion. The other outlet is attached to an existing but non-operational Mini-Hydropower unit that has sustained significant damage, hence rehabilitating it being a subject of this study.

The structure of Katse Dam Mini-Hydropower plant comprises of three major components: civil works, electro-mechanical equipment and the electrical distribution network [5].

The downstream manifold pipework of the Mini-Hydropower plant is 600 mm in diameter, which also forms the other manifold for two 400 mm diameter pipelines to the present and prospective turbines' main inlet valves [5], [6]. The horizontal layout of the MiniHydropower is used. Three load demand scenarios were considered in the Mini-Hydropower design, namely 1) Mini-Hydropower connecting to the LEC system via the power network; 2) Mini-Hydropower feeding the Thaba-Tseka District; and 3) Mini-Hydropower feeding camp and dam auxiliaries of 430 kW and 280 kW [5], [7], [8].

The current Mini-Hydropower plant is rated at 650 kVA and has a power output capacity of 500 kW at 3.3 kV generator voltage, with a 3.3/11 kV transformer connecting to the dam load of 280 kW. The switchgear is then connected to the Lesotho Electricity Company line as well as the Katse Dam backup diesel generator [5], [7], [8]

The Mini-Hydropower components are divided into four categories based on their use in water and electrical systems: water turbines, generators, control and protection, and transformers.

## **1.2 Problem Statement**

The Katse Dam Mini-Hydropower station is currently out of service due to substantial damage to its primary components, some of which are antiquated, including the electromechanical components. Therefore, the planned purpose of exploiting the compensating discharge's hydropower potential is not met. As a result, the auxiliary systems' supply is drawn from the national grid, resulting in an annual electricity bill to LHWP of two hundred and thirty eight thousand six hundred United States dollars (\$ 238 600.00), and annual energy consumption of 3.76 megawatts hour MWh [9].

The national grid line (LEC power line) at the Katse Dam area is frequently cut-off. This requires frequent use of backup supply, which has now resulted in the stand-by diesel generators clocking 356 running hours, equivalent to 356 hours of environmental pollution.

In addition to environmental pollution, this frequent grid separation requires the LHWP to engage manpower on stand-by to ensure a smooth operation of the plant, thereby also attracting extra operational costs of manual grid separation. The current situation necessitated a study to evaluate options for rehabilitating the Mini-Hydropower station and increasing overall power generation capacity.

### **1.3 Objectives of the study**

This study aims at rehabilitating Katse Dam Mini-Hydropower to achieve its ultimate goals: reliable and sufficient power generation at a low cost. In order to achieve this, the study assessed the conditions of pre-existing equipment in order to test and explore the possibility of increasing power generation capacity and checking the stability of grid after integration. The following objectives are therefore stipulated for these outcomes to be achieved:

- To determine the extent of component damage and the most cost-effective approach to plant rehabilitation;
- To explore the possibility of expanding the plant's capacity;
- To evaluate the viability of the grid integration as another option.
- To evaluate the impact of various switching events on network and machine stability model using a DigSilent PowerFactory program.

### **1.4 Research questions**

The following questions were answered in order for this study to meet its objectives:

- Is it possible to use equipment that has already been installed?
- What went wrong with the Mini-Hydropower?
- Is it possible to expand the generation capacity from 0.5 MW to 1 MW?
- Is it possible to connect the Mini-Hydropower plant to the national grid?

### **1.5 Significance of the study**

The rehabilitation project is well justified because it has the ability to benefit LHDA, the Trans Caledon Tunnel Authority (TCTA), and LEC, as well as the general public. Since the cost of operating and maintaining the Katse Dam systems is borne by both Lesotho and the RSA Ministries responsible for water affairs, the study presented to help both entities decide on the best option for reviving the plant. The study also looks at how dispersed generation affects grid stability and measures that need to be taken by the grid operator, LEC. The report will also guide policymakers in assessing the pros and cons of using independent electricity

producers. It also highlights the hydropower potential of the Katse Dam's compensating outflow to the Malibamatšo River.

Rehabilitation of the electrical and mechanical equipment at the Katse Dam MiniHydropower plant will also help to: a) utilize the hydropower potential in the compensation discharge and improve water resource utilization. b) enhance access to pollution-free renewable energy which constitutes part of Sustainable Development Goal 7 (SDG-7), increase electrical supply stability and continuity, and decrease reliance on the national grid [10], [11]. c) Encourage economic growth and job creation, as there will be a need to expand the maintenance crew [11]. d) Lower electricity costs for the Lesotho Highlands Development Authority (LHDA), because electricity will be dedicated to LHDA's essential facilities.

Lesotho's contribution to the national grid will be increased, reducing the quantity of electricity imported from neighbouring nations. Plant life will be extended and the maintenance requirements will be reduced by upgrading equipment to meet modern standards and characteristics [12].

### **1.6 Limitations/scope of the study**

The condition assessment of the components was limited to electro-mechanical equipment and did not include the civil structure. Thus, limitation exists due to lack of funding and proof relating the Mini-Hydropower failure to the civil structure. Only the components that could be tested on-site were used in the functionality condition assessment tests on electromechanical equipment. To save on the expenditures of equipment dismantling, packing, and transportation, these tests were limited to on-site testing.

The study was also limited to evaluating the rehabilitation process rather than implementation, therefore the scope of the study did not include leaving the plant operational. The study further looked at the impact on flow dynamics when adding an extra generating unit parallel to the current unit without changing the structure for the plant capacity increase.

### **1.7 Summary of the methods used in the study**

In order for the study to fulfill its goal and meet its objectives, a tripartite strategy was used in the analytic method: 1) a condition assessment method that evaluated both the physical and operational conditions of the equipment [13]; 2) a hydrological assessment that evaluated the possibility of increasing power generation; and 3) a computer software package that evaluated the generation to load adaptation option [14], [15]. In addition to these, an

economic evaluation of the undertaking was performed by confirmation of the firm energy yield duration against the auxiliary energy requirement.

### **1.8 Organization of chapters**

Chapter 2 on the literature review, presents work of different scholars that cover the MiniHydropower plant restoration, and the pros and cons of different Hydropower rehabilitation methods. The chapter plays a reflexive role. It reflects the works of other scholars contemplating their contribution to the rehabilitation of hydropower plants. Most significantly in this chapter is the possibility of rehabilitation and its economics. The reason for rehabilitation is highlighted. Most Hydropower plants are being rehabilitated because of damage to components. Other scholars point out that harnessing water resources for Hydropower generation is another reason for rehabilitation. On the other hand, plant upgrading to meet new market standards and plant capacity improvement are considered reasons for rehabilitation. The chapter further expounds on different considerations to power generation capacity increase, while also highlighting the energy dispatch options.

In Chapter 3, appropriate rehabilitation methods for Katse Dam Mini-Hydropower were explored. The methodology forms the critical part of the study which unfolds how the objectives are met. Choosing appropriate rehabilitation methods necessitates two major actions that define rehabilitation: repairing or replacing damaged components and restoring the plant. The discussion of these methods continues to revolve around component condition assessment. Furthermore, the platform chosen for possible grid integration of Katse Dam Mini-Hydropower station to evaluate the impacts of various switching events on network and machine stability is given special attention in this chapter for network stability assessment.

The objectives of this study are addressed in Chapter 4 through the results obtained using the methodology outlined in Chapter 3. The extent of equipment damage is assessed, and the possibility of increasing plant capacity is investigated. In other words, the results obtained from the components or equipment (electro-mechanical) after appropriate tests are the focus of this chapter. These findings are analyzed, and the conclusions drawn from them are used to make a decision on the urgency of rehabilitating the plant. The chapter gathers evidence of the data's relevance to the study objectives and applicability to existing similar projects. The chapter also includes an analysis of the project's viability and economics.

Chapter 5 summarises the key findings in the results. Each chapter briefly brings forth the major content that contributes to the final conclusion of the entire study. Recommendations

aimed at assisting with the implementation and further research are drawn from the highlights of the findings and conclusions.

## **Chapter 2: Literature review**

This chapter focuses on the electro-mechanical equipment, key indicators for the possibility of rehabilitation, and exploration of the possibility of uprating and grid integration. The methods of rehabilitation as well as the elements that influence the process are reviewed in detail.

### **2.1 Rehabilitation**

According to Holbert and Kwon, rehabilitation is a process of replacing, modifying, or adding equipment to an existing hydro facility to restore the facility's safety, reliability, maintainability, or operability [16], [17]. In literature, there are different terminologies for rehabilitation of the Hydropower Plant. Goldberg and Lier use the term "rehabilitation" for equipment; rotor, stator, turbine, and the transformer, while on the other hand, Holbert and Kwon use the word "modernization" for this equipment, except for the transformer where rehabilitation is used like Goldberg [16], [18]. Rahi and Chandel use the word refurbishment for the electromechanical equipment of the hydropower plant [19].

Most technically, and in the intrinsic specification of the words, refurbishment (Chandel) and modernization (Holbert), the two words are intrinsically interwoven in the word rehabilitation [16], [19]. Rehabilitation therefore remains an umbrella term and goes beyond the limitations of both refurbishment and modernization. Since rehabilitation is not changing the whole system but targets only a part of a system, it comprises repairing and/or replacing certain parts of the major components [20]. In this case, the electromechanical equipment. Therefore, rehabilitation is characterized by these two most significant words: repair and replacement.

### **2.2 A need for rehabilitation**

Upgrading and uprating are significant motivations for rehabilitation, according to Goldberg and Lier [18]. They both involve the equipment repair and replacement (rehabilitation). Equipment is repaired and replaced if the parts have been damaged by harsh exterior circumstances or have become fatigued as a result of old age. This therefore renders rehabilitation a requirement for these two primary reasons: a) upgrading and b) uprating [12]. In addition, Rahi and Chandel cite optimal water potential utilization as additional motivation for hydropower plant repair and upgrade [19].

### 2.2.1 Upgrading

Upgrading is done to extend the life of a piece of machinery/equipment [17], [21], [22]. By altering the management of water resources to promote ecosystem [17], [18], it is possible to improve generation availability and capability, realign services to meet new market opportunities and requirement.

### 2.2.2 Uprating

Uprating is the process of increasing generation capacity. It is a technical cause for upgrading [17]. In Chapter one, under research questions in Section 1.4, this study is focused on determining whether there is a potential of doubling the capacity of the Katse Dam MiniHydropower plant. With uprating, additional production is accomplished, and the fundamental reason for building a Mini-Hydropower plant becomes or remains relevant.

## 2.3 Classification of equipment for rehabilitation

Holbert and Kwon divide rehabilitative equipment into two categories. The stator, rotor, turbine, and transformer are all part of group one equipment [16], [23]. Excitation, governor, main circuit breaker, and switchyard circuit breaker are all part of group two equipment [16], [20]. For the purpose of this study, both types of equipment are considered.

Control system, governor, turbine assembly, excitation system, and generator equipment are all identified for rehabilitation by Rahi and Chandel [19], [20]. For rehabilitation, Erbisti determines the civil structures that are prone to failure [24]. Arias, Fan, and Morries identify siltation as the cause of hydropower plant hydraulic system flow problems [25], [26]. On the other hand Alam, Kondolf, Wild, and Wang believe sedimentation is a factor in hydraulic system failure, although they do not believe it is the only factor [27]-[31].

## 2.4 Factors affecting rehabilitation of hydropower

The essential components of a hydropower plant, especially the electromechanical equipment, continue to be damaged. Age and operating condition parameters are identified by Goldberg and Lier as factors that affect hydropower plant rehabilitation [18]. According to Goldberg and Lier, component fatigue is a prominent indicator of plant aging and harsh operating conditions [12]. Other factors impacting rehabilitation and uprating hydropower plants, according to Rahi and Chandel's study, are defects in designs and plants nearing the end of their useful lives [19].

### 2.4.1 Age and operating conditions

Deterioration occurs at some point or in the presence of unfavourable working conditions [32]. Deterioration, or even damage, on the other hand, is still an enemy of a working instrument. Turbines and generators are frequently targeted [18], [33]. Welte also discusses the equipment that is directly affected in the major parts [23]. In the sub-sections that follow, some of the aspects that affect the rehabilitation of specialized hydropower equipment are explored.

#### 2.4.1.1 Turbines

Cavitation pitting damage to turbine runners or blades is possible. Research indicates that blade damage can occur quite close to the trailing edge [23]. Damage that occurs near the leading edge of the runners is considerably more harmful [18], [23]. Again, cavitation damage to the turbine wicket gates could be the cause. Two mechanisms are thought to weaken the parts of a turbine to the point of destruction: cavitation pitting damage and cavitation damage [18], [23]. This demonstrates that turbine runner/runner blade cavitation is one cause that may contribute to turbine rehabilitation.

Furthermore, runner blades are susceptible to shattering [18], [23]. This could be due to exhaustion produced by constantly varying large loads [18], [23]. Aside from that, hard deposit loads containing quartz lead to equipment damage [18], [23]. Both the wicket gates and the runner suffer greatly from this abrasion process. These are operating circumstances that have an impact on turbine components [18], [23].

#### 2.4.1.2 Generators

A hydropower plant's generator is another crucial component. Parts of the generator are also susceptible to wear and tear; the generator stator and rotor windings, as well as the bearings [18], [23]. The components of the generator are affected by circumstances that contribute to generator rehabilitation, and these factors are described.

#### 2.4.1.3 Stator windings

The age factor has a direct impact on the generator's stator windings. Statistical data suggests the stator winding should give 45 years (or more) of reliable operation based on historical winding experience [18].

#### 2.4.1.4 Generator rotor

During operation, the generator rotor is damaged [23]. The shape and alignments are distorted as a result of poor performance caused by several processes such as field flashing, over speeding, and even synchronization [18], [23].

## **2.5 Predictors of rehabilitation of hydropower plants**

Many researchers have identified age, operational conditions, trouble locations, component condition, maintenance expense, and breakdown period as indications of hydropower plant rehabilitation [34]. Plant efficiency loss, energy output loss, and forced outages are markers for plant uprating [34].

For these reasons, it is critical to think about the technique for determining the extent of component damage. Goldberg devises what he refers to as the Rapid Assessment Tool [12], [35]. It is called Hydropower Assessment Tool (HAT) for this purpose. This procedure was implemented by an independent consultant (Terry Molstad).

Age, operational circumstances, trouble spots, component condition, maintenance cost, and breakdown period are all indications of hydropower plants that need to be rehabilitated, according to many researchers [34]. Plant efficiency loss, energy production loss, and forced outages are all signs of plant uprating [34].

As a result, the technique for assessing the level of component damage remains critical. Goldberg devises a Rapid Assessment Tool [12], [35]. Hydropower Assessment Tool (HAT) was created for this aim.

A spreadsheet application has been created to automatically detect the potential for rehabilitation in order to carry out this type of assessment. "First, the spreadsheet chooses candidate hydropower facilities from a database of power plants. It next applies the condition assessment procedures to each of the proposed hydropower plants' units, assigning fast evaluation ratings to each component" [12].

This evaluation includes four tests:

- i) Plant type
- ii) Operational status
- iii) Plant size
- iv) Condition assessment

### 2.5.1 Hydro Asset Trigger Age (HAT)

The hydro asset trigger age is used to rate the different components. This trigger detects the component's condition age [12]. However, it does not give reference to condition assessment, or even the level of maintenance a particular component may have been earlier subjected to [12].

#### Particular weaknesses of this method

Goldberg established in all possible ways and proved beyond possible doubt that hydropower plants may need rehabilitation, or perhaps some major components of hydropower [12]. The excellency in which possible damage and deterioration to particular components has been categorically established is highly remarkable [12].

However, for two reasons, the assessment method for determining the potential for rehabilitation leaves traces and fragments of dissatisfaction:

1. The hydro asset trigger is only confined to assessing or detecting the age condition, in which the year marked may not be very specific, depending on the type and size of the particular hydropower plants.
2. Because this approach does not use site-specific knowledge for visual assessment, more plant problems may be neglected.

#### Adaptability to a particular function

How the hydropower assessment tool is made in such a way that it is adapted to this particular function is not established. It carries some weakness as it may not be able to detect damage caused by operating conditions. It is only confined to age factor, which, at the same time, may not be as accurate.

### 2.5.2 Visual Inspection (VI)

Some common faults on hydropower plant components discovered by numerous studies as a result of age and operational condition cannot be detected by testing, instrumentation, or any other approach other than physical observation [18], [19], [35]-[37]. This examination may also necessitate the use of visual technology aids such as an endoscope and an infrared camera. Cavitation, abrasion, and cracking in a turbine assembly and turbine inlet valve, as well as arc deposits on stator, rotor, and transformer windings, are among the examples of faults that require physical observation.

However, in this method, site specific knowledge may not be as accurate. In order to thoroughly diagnose the problem through observation, a dismantling of the components is required, and this may be economically costly as it may involve expertise. Dismantling may also cause unnecessary damage to components.

### 2.5.3 Equipment Testing (ET)

Conditions of some plant components cannot be determined from the ground level or through their age, hence must be assessed operationally. Other components require a significant amount of manpower to dismantle in order to determine their status. Equipment testing allows equipment to be evaluated for functional state without having to dismantle it, making it easy to determine its health status.

Induction machine fault diagnosis methods are presented by Yazidi et al. for both electrical and mechanical defects, such as bearing, rotor, and stator faults, as well as insulation breakdown [38]. Theoretical considerations and laboratory studies related to generator stator windings are presented by David et al. to detect stator insulation fatigue as a result of mechanical, electrical, thermal, and environmental stress [39]. Stone discusses rotor and stator winding insulation online and offline tests and monitoring systems [40].

#### Recommended standard

Testing insulating resistance of electrical gear is recommended by the Institute of Electronic and Electrical Engineers (IEEE) [41]. The measurement of insulation resistance and polarization index (PI) of winding insulation of spinning electrical equipment is presented by the International Electrotechnical Commission (IEC) [42]. The IEEE advises that electric equipment stator coil insulation be measured for power factor tip-up [43]. The IEC also presented the measurement of dielectric dissipation factor on stator winding insulation in rotating electrical machines [44].

According to ASTM D5185, Bartsch proposes a lubricating oil analysis method for evaluating additive elements, wear metals, and pollutants in used lubricating oils, as well as the determination of selected components in oil utilizing the thermal scientific iCAP 7400 ICP-OES [45]. ASTM also has guidelines for sampling, testing methodologies, and specifications for electrical insulating oils of petroleum origin, as well as the acid number of petroleum products determined by potentiometric titration and reagent water [45]-[47]. A standard test technique for acid and base number by colour indicator titration is also presented by ASTM [48]. Testing of contaminated particles in oil is described in ISO 4406 [49].

Aj et al, presented causes of transformer failures and diagnosis methods [32]. Pukel et al. presented transformer diagnostics: commonly used and new methods [50]. K uchler et al. presented transformer insulation diagnosis by polarization and depolarization current analysis [51]. Additionally, Duval and dePabla, presented a publication containing an in-depth description of the five main types of faults usually found in electrical equipment in services [52]. Dukam et al. presented methods used for fault type identification in dissolved gas analysis (DGA) of oil filled high voltage transformers and other electrical apparatus [53].

The transformer commonly used fault diagnostic methods are based on chemical, electrical, thermal, optical, and mechanical diagnostic methods of which each use a specific test procedure [54]. The chemical diagnostic methods involve the oil analysis for moisture, furan values, and neutralization value and dissolved gas analysis (DGA) using IEC-599, IEEE C57.104-1991, Domenburg, Rogers, Duval and other methods [54]-[56]. The electrical diagnostic methods involve oil analysis by loss factor and breakdown voltage, partial discharge using PD-evaluation among others [57].

The use of thermography and temperature monitoring as part of thermal diagnostic methods [54]. Acoustics employing ultra-high frequency partial discharge (UHF PD)-detection and operation noises are used in mechanical diagnostic procedures, as are dynamics using transient oil pressure and oil stream [54]. Fibre optics, as well as an eye and endoscope, are used in optical diagnostic methods [54].

#### 2.5.4 Equipment Instrumentation (EI)

Various condition monitoring studies have used equipment instrumentation status as one key indicators in determining the history of a plant's operation, which indicates the maximum reached limit and their footprints during operation. Flow meters, temperature and pressure gauges, power, voltage, current, and fault indicators, and guide vanes and valves position indicators are among these devices [19], [51], [50], [58].

This method is more useful on a live plant, but the information needed for a dead plant can only be collected via equipment that leave imprints [51], [59]. However, misdiagnosis of defect due to instrument malfunction is possible.

## 2.6 Uprating and Grid Integration

Rehabilitation/refurbishment and uprating are commonly linked in hydropower research [19], [12], [60].

### 2.6.1 Methods employed for uprating

Uprating is a crucial aspect of rehabilitation, according to Rahi and Kumar [60]. Apart from reinstating certain parts of a major component to their original state, uprating may also be performed for a larger discharge for economic reasons [60], [61].

### 2.6.2 The possibility of uprating

Rahi and Kumar, renewable energy scholars, discuss ideas for upgrading hydropower plants. In their scholarly article titled: "The second alternative for refurbishment and uprating has been studied," Rahi and Kumar write about the economic analysis for refurbishment and uprating of hydropower plants [60]. The new increased capacity has been reached. Rahi and Kumar are not just referring to a specific research conducted here, but also to uprating that has already been completed and has proven to be successful in the implementation of these choices [60], [61].

Rahi and Kumar outline three options for refurbishment and uprating.

1. Stator rewinding

This is the most straightforward technique to enhance generation capacity by upgrading equipment. Rewinding the stator and increasing the number of turns can boost the generator's capacity [60].

2. Installing a turbine generator.

Installation of a high capacity generating turbine is another alternative [60].

3. The addition of machines of various capacities to increase capacity.

Rahi and Kumar consider constructing a second machine next to the present one to allow capacity growth [60].

After reviewing the solutions offered by Rahi and Kumar, it is critical to examine the time period and cost of rehabilitating the hydropower plant [60]. Option one is awarded credit above the others because it examines an economical budget in light of these two significant factors [60]. The other two are somewhat costly, which may put off potential donors [60].

As a result of higher load supply, which in turn results in an increased generation capacity, excess energy damping solutions must be considered during rehabilitation and uprating. However, for system operational stability, the influence of increasing hydropower load must be considered [62], [63].

Power system stability assessment is required for the safe operation of a plant [64]-[66]. The ability of a power system network to withstand several network disturbances while maintaining operating equilibrium is referred to as power system stability [67], [68]. Small and large network disturbances are two types of disturbances that impact power system stability. Small disturbances include incremental or decremental changes in load and generation, whereas big disturbances include entire generator or load loss owing to transmission line faults or scheduled maintenance [62], [68].

### 2.6.3 Power system stability classification

There are two types of power system stability: steady state and transient [63], [68]. Voltage stability is part of the steady state stability, while rotor angle stability is part of the transient stability [68].

#### 2.6.3..1 Steady state stability; Voltage stability

Voltage stability refers to a power system's capacity to maintain a constant voltage level across all buses during normal operation and after a disruption [68], [69]. A stable system has a positive voltage (V)–(Q) sensitivity of all system buses, whereas an unstable system has a negative voltage value of at least one system bus [68].

#### 2.6.3..2 Transient stability; Rotor angle stability

The capacity of the power system to keep all interconnected synchronous machines in synchronism after a disruption is known as rotor angle stability [69], [70]. In addition, the capacity of synchronous machines to remain synchronized under small disturbances (small signal) is referred to as rotor angle stability [69], [70]. Small disturbance stability, according to Kundur et al, is influenced by the system's initial operating state [71]-[73]. Furthermore, small disturbance rotor angle difficulties are linked to insufficient oscillation damping in power systems [71]-[73]. Substantial disturbance (transient) stability, on the other hand, refers to the ability to maintain synchronization in the face of large disturbances [69], [70]. Cutsem and Vournas relate rotor angle instability with a progressive decline in bus voltage, whereas Kundur associates it with a progressive drop in rotor angle stability [71]. According to Cutsem and Vournas, transient instability is associated with small power systems. [74].

Even though the most typical instabilities are voltage progressive drops in bus voltages, Kundur et al note an overvoltage instability occurrence in one of the systems [68], [74]. Kundur et al. also propose a basis for separating voltage and rotor angle stability. The distinction, according to the author, is based on a specific collection of opposing forces that

experience continuous imbalance and the major system variables that manifest the resulting instability [68].

## **2.7 Project Economic Analysis**

The rehabilitation of a hydropower plant is a massive undertaking. It is thus a critical decision to decide on the refurbishment and upgrading of hydro power plants. An economic analysis is unavoidable in all aspects of it.

Rahi and Kumar believe that the economic aspect of all engineering projects is critical. According to these experts, considering the economic factor is important because it determines the feasibility of the project [60]. The economic problem may arise for a variety of reasons, including electrical power distribution and utilization, and, more importantly, refurbishment and upgrading schemes [60]. As a result, Rahi and Kumar advise that it is critical for an engineer to consider the most cost-effective, optimal, and convenient scheme first [60].

Adding to Rahi and Kumar's advice Li et al. state that the optimal hydropower scheme is characterised by the energy yield from the hydropower units, and according to these experts, the daily load dispatch is the most appropriate pointer [60], [75]. The scholars also identify the water head distribution and discharge as main components of the daily energy yield [60], [75], [76]. Hydropower researchers further consider optimal hydropower design to be characterised by the firm power capacity of the power station [75]. Firm power is defined as the power available at all times upon demand, except for forced outages, which could be due to scheduled or forced maintenance [75], [76]. It is therefore in the interest of this dissertation to consider the firm power yield of the rehabilitated Katse Dam mini hydropower plant for the project viability.

According to literature, most Hydropower Plants are rehabilitated mainly due to components' damage. It is also highlighted in several studies that another reason for rehabilitation can be harnessing water resources for Hydropower generation and/or plant upgrading to meet new market standards; and, to improve the plant capacity. The reviewed studies point out stator rewinding, installing turbine generator and addition of more machines to increase capacity as the major rehabilitation methods. The next chapter, Methodology, outlines the procedure for assessing of hydropower components' damage and water resources and network stability.

### **Chapter 3: Methodology**

The methodology for the Katse Dam Mini-Hydropower plant rehabilitation study is presented in this chapter. The aim of the research is to determine the current state of the plant, the level of equipment or component damage, and the root cause of the plant failure. The research establishes which components should be prioritised for repairs and also considers if the plant can be upgraded and its load increased. The focus of the restoration is mostly on electromechanical equipment, and it excludes structural changes involving civil works. However, the availability and duration of the water hydraulic system must be evaluated.

The following are some of the suggested methods:

#### **3.1 Condition Assessment**

The assessment techniques by Goldberg et al were used to assess the state of plant electromechanical equipment [12], [19], [35], [60]. Based on their state, possible rehabilitation considerations such as repair of damaged equipment parts or replacement of the entire plant part are made [12], [35]. The condition assessment is defined by the condition assessment filter, which consists of the following filtering processes:

- The hydro asset trigger age (HAT)
- Visual inspection (VI)
- Equipment testing (ET)
- Equipment instrumentation (EI)

#### **3.2 Hydrological Assessment**

The reliability and availability of the Mini-Hydropower water resources were assessed for plant capacity expansion and design parameters confirmation [60]. Included in the evaluation are the following:

- Discharge ( $\text{m}^3/\text{s}$ ) versus % assurance;
- Net head (m) versus % assurance;
- Power potential (MW) versus % assurance;
- Head versus discharge at rated conditions, 0.5 MW for a single machine and/or 1 MW combined at various rated discharges.

Researchers believe that siltation and sedimentation are the primary causes of hydraulic system failure, but pipework failure can be caused by age fatigue or inconsistent water flows, which is not the case with the Katse Dam Mini-Hydropower application [27], [31], [33], [77],

[78]. As a result, the evaluation is limited to a review of historical dam data, such as water surface elevation and compensation release history.

### 3.3 Stability Assessment

The network stability assessment is performed, when each of these conditions listed below occurs during plant operation [34], [72], [73], [79]:

- Synchronising to the grid
- Separating from the grid either planned (due to generation schedule or plant maintenance) or unplanned (fault condition).
- Load variation (increasing or decreasing load due generation schedule).

These methods are covered separately in Section 3.4 of this chapter and are based on the requirements of each process, with the methods complementing each other where suitable.

### 3.4 Rehabilitation Methods

Two major actions characterize rehabilitation: repairing or replacing damaged components and restoring the plant. The condition assessment is crucial to the rehabilitation process for these two reasons [17]. The decision on which action to take to facilitate the process is informed by the condition assessment, which is described in depth in this section.

#### 3.4.1 Condition assessment of components

Goldberg and Lier provide the first research question that the proposed methodology addresses [13]. **Figure 1** below shows a process diagram that summarizes one of the rehabilitation phases. This method examines the state of selected plant components to evaluate whether they are still useful, repairable with minimal cost, and capable of producing the desired output. The plant failure root cause analysis is aided by the condition assessment process [17], [35].

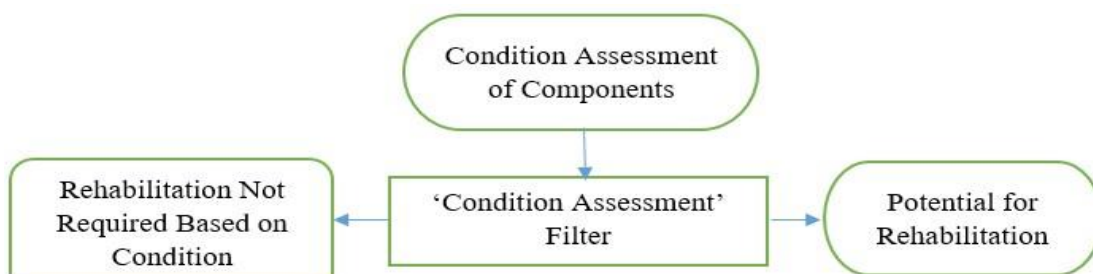

**Figure 1:** Process flow diagram for Condition Assessment of components [13].

The condition assessment filter is used as a criterion in the process flow diagram shown in

**Figure 1** above to determine if the plant components are useable based on their condition. The condition assessment filter criterion is divided into constituents that can be used to categorize component condition based on a variety of factors.

The first characteristic that can be utilized to identify component condition, according to Goldberg and Lier, is component age, which is classified as the Hydro Asset Trigger (HAT) Age [13]. The number of component service years must be known in order to employ this HAT age factor, and this yields the rapid assessment rating [13].

The second consideration is the evaluation of the components' physical, structural, and operational conditions. Physical condition assessment considers corrosion, cavitation, abrasion, wear, and other factors, while structural condition assessment considers real structural changes produced by deformation (both physical and thermal), fatigue (cyclic loading), and other factors [36]. Apart from that, operational condition evaluation focuses on equipment testing for operational malfunctions including pressure testing, insulation resistance, polarisation index, and oil sampling [41], [49], [50], [80].

The generator stator and rotor, transformer, protection, and governor hydraulic system are among the essential components of the Mini-Hydropower plant that require operational condition assessment, as detailed in Section 2.3, with specific tests discussed in Sub-section 2.5.3. While the physical and structural condition evaluation in Sub-section 2.5.2 applies to all equipment in Section 2.3 because it entails a physical examination, it is not relevant to all equipment in the section.

### 3.4.2 Hydro asset trigger age of components

The plant components are categorised according to their condition assessment filter by age factor, as shown in **Error: Reference source not found** below. The common electromechanical equipment of the plant is displayed, each with a rapid assessment evaluation rating age that indicates its economic and technical lifetime [81]. The ratings range from good to poor, with good representing the fewest years and poor being the greatest. The rating represents the number of years that the component has been in service in the plant.

**Table 1:** Rapid Assessment Rating [35], [82].

Plant Subsystems	Economical Lifetime (years)	Technical Lifetime (years)	Rapid Assessment Rating		
			Good ( $\leq$ )	Fair ( $\leq$ )	Poor ( $>$ )

<b>Electrical Installations</b>					
Generators	25-40	30-60	25	45	45
Transformers					
High Voltage Switchgear	20-25	30-40	20	35	35
Auxiliary Electrical Equipment					
Control Equipment					
Batteries	10-20	20-30	10	25	25
DC Equipment					
<b>Mechanical Installations</b>					
Kaplan and Francis Turbines	30-40	30-60	30	45	45
Pelton Turbines	40-50	40-70	40	55	55
Pump Turbine	25-33	25-50	25	33	33
Storage Pumps					
Gates	25-40	25-50	25	37	37
Butterfly Valves					
Special Valves					
Cranes					
Auxiliary Mechanical					

### 3.4.3 Visual Inspection of components

All equipment that can be physically inspected is subjected to a visual inspection to determine its physical and structural condition. The components are grouped according to their functioning within the generation process as illustrated in **Table 3**, and this condition evaluation process follows the structured inspection technique as shown in **Table 2**. The turbine is made up of all the water system components as well as their controls, and it is used in the generation process to transform water kinetic energy to mechanical energy [18]. The generator is a component of the process that converts mechanical energy to electrical energy [17], [83].

**Table 2:** Physical and Structural Condition Assessment Sheet [35].

No.	Component	Part	Evaluation			Observation
			A	B	C	
1	<b>Turbine</b>	Runner				
		Spiral Casing				
		Speeder Ring				
		Guide Vanes				
		Turbine Bearing				
		Governor				

		Main Inlet Valve				
2	<b>Generator</b>	Stator				
		Rotor				
		Guide Bearing				
		AVR/Excitation				
3	<b>Control and Protection</b>	Control panel				
		Generator CB				
		Protection				
4	<b>Transformer</b>	Main transformer				

Evaluations are graded on a scale of A to C, with "A" being the poorest and "C" representing the best state for rehabilitation [81]. The importance of component rehabilitation is assessed to generate data regarding equipment health by assigning each a value/point/weighting rating scaled between 1 and 10, with "C" ranging from (1-3) and "1" being best and "3" good; "B" at (4-6) and "A" at (7-10) [19]. During the inspection, the following observations are made and an applicable category is chosen [19], [81].

A: This signifies significant degradation and necessitates immediate repair.

B: This indicates early indicators of deterioration and requiring repairs and/or refurbishment in preparation for annual inspection (AI) or a significant machine overhaul (MO), and

C: There have been no symptoms of degeneration yet, although frequent maintenance is advised [81].

**Table 3:** Hydropower Electro-Mechanical Components, Parts, and Possible Problems as identified [18], [35], [83].

No.	Component	Part	Functions	Possible problem
1	<b>Turbine</b>	Runner	Converts hydraulic energy to mechanical energy	Cavitation or corrosion
		Spiral Casing	Embedded water passage to runner	Crack and corrosion
		Guide Vanes	Adjust water volume to runner	Crack due cavitation or corrosion
		Turbine Bearing	Support turbine shaft	Vibration, high temperature
		Governor	Adjust speed and load of water turbine	Non control of speed and load
		Main Inlet Valve	Open and close water passage to turbine	Water leakage
2	<b>Generator</b>	Stator	Generate voltage	short circuit or earth fault of windings

		Rotor	Convert mechanical energy to electrical energy	short circuit or earth fault of windings
		Thrust Bearing	Support rotor and generator shaft	Vibration, high temperature
		AVR	Adjust generator voltage	non control of voltage
3	<b>Control and Protection</b>	Control panel	Operates and control machines, record events and status	non control of machines
		Protection panel	Protect machines from faults	Malfunction of protection
4	<b>Transformer</b>	Main transformer	Step-up generator voltage to high voltage	High temperature, oil leakage

#### 3.4.4 Equipment operational tests

The tests done on various plant equipment for the operational condition evaluation procedure are detailed in this section. Each Sub-section from 3.4.4..1 to 3.4.4..3. discusses specific tests for each component.

##### 3.4.4..1 Generator stator and rotor windings

Different standards guide the tests used to examine the health of stator and rotor windings, and the most generally used offline tests are the polarization index (PI) and dielectric absorption ratio (DAR), as discussed in Sub-section 2.5.3. **Table 4** displays the dielectric absorption ratio suggested values for insulating resistance, and **Table 5** gives the polarization index recommended values, both according to IEEE [84]. Equation 1 below is used to compute the winding's dielectric absorption ratio.

$$DAR = \frac{R_{60}}{R_{30}} \dots\dots\dots [1]$$

Where  $R_{60}$  is the insulation resistance measurement obtained after 60 seconds,  $R_{30}$  is the insulation resistance measurement taken after 30 seconds, and DAR is the dielectric absorption ratio. When the electric field is supplied to the insulation system, this number reflects the polarising current pulled for dipole alignment within the dielectric [85]- [87]. The higher the DAR value, the better the insulation condition, and the lower the value, the worse the insulation state.

**Table 4:** Dielectric Absorption Ratio Recommended Values [84], [88].

Insulation Condition	DAR Results	Calculation
Poor	<1	DAR = IR60sec/ IR30sec

Acceptable	1-1.4
Excellent	1.4-1.6

The polarization index of the winding is calculated using equation 2.

$$PI = \frac{R_{600}}{R_{60}} \dots\dots\dots [2]$$

Where  $R_{600}$  is the insulation resistance measurement after 10 minutes,  $R_{60}$  is the insulation resistance measurement after 1 minute, and PI is the polarization index. This value indicates winding surface contamination from dust or salts, which may become partially conductive when exposed to moisture [84]. The insulation resistance value decreases as a result of surface leakage current flow on the winding surfaces caused by foreign matter deposits such as oil or carbon dust [84]. The higher the PI value, the less or no pollution on the winding surface, and the lower the PI value, the poorer the insulating state.

**Table 5:** Polarization Index Recommended Values [84], [88].

Insulation Condition	PI Results	Calculation
Poor	<1	PI = IR10min / IR1min
Questionable	1-2	
Acceptable	2- 4	
Excellent	>4	

3.4.4..2 Generator transformer

As described in Sub-section 2.5.3 [57], transformer faults are often linked to transformer components, with the windings, bushings, core, switching devices, tank, and cooling system incurring the most failures [57]. The tests in this study were carried out on a dry-type transformer, rendering most of the testing indicated in the literature obsolete. Offline partial discharge between the windings and earth or core utilizing polarization index and dielectric absorption ratio tests are recommended for the dry type as specified in section (generator stator and rotor windings) [59].

3.4.4..3 Governor and bearing lubricating hydraulic systems

The standards described in Section 2.5.3 of the literature review guide the governor and bearing lubricating hydraulic system oil tests [45], [49], [47]. The tests are used to evaluate the governor and bearings' hydraulic system for leaks in seals, wear particles, overheating,

and other indicators based on the oil test results. Water content, particle number, viscosity, and total acid number are all indicators of a specific state, according to these standards.

### 3.4.5 Equipment Instrumentation

When a hydropower plant is not in operation, the instrumentation installed in the facility may signal when some plant sections are malfunctioning. The main inlet valve, guiding vanes, and all mechanical isolating valves with seals are examples of this equipment; when these seals fail, isolated fluid leaks through even when fully closed, allowing pressure lapse or build-up. Pressure gauges, flow meters, and position/level indicators for mechanical assembly are among the instruments observed during the condition assessment and instrumentation for electrical assembly includes power, voltage, current, and frequency meters.

Instruments give the plant condition except when it is faulty and may give erroneous readings. When the plant is entirely isolated, for example, zero (0) flow is expected on the turbine, and the turbine flow indicator should display zero flow. If the measurement is greater than zero, the main inlet valve is not sealing properly, unless the flow meter is stuck in the open position.

Physical inspection of equipment instrumentation and study of plant historical operational data records are all part of this method's implementation, which enables for the assessment of behavioural tendencies. The condition is then appraised after the observation.

### 3.4.6 Condition assessment filter scale

**Table 6** summarizes the plant condition filtering process using a value/point/weighting ratings scale. Each condition is given a weighted scale with a points' scale that distinguishes between extreme and normal cases in each grade. As shown in **Figure 1**, rehabilitation priority and the decision to rehabilitate or not are highlighted based on the highest point rating of the components [19], [35].

**Table 6:** Condition Assessment Filter Rating Scale.

Condition Assessment Filter	Rating Scale (1-10)		
	Good (1-3)	Fair (4-6)	Poor (7-10)
Hydro Asset Trigger			
Visual Inspection			
Equipment Testing			
Equipment Instrumentation			

### 3.5 Hydrological assessment

The sources and types of hydrological data needed to evaluate the power potential and machine configuration for the present structure are covered in this section. The precision and dependability of hydrological data needs are also discussed in this section. There is also a hydrological assessment and an examination of the compensating system's operational philosophy. After rehabilitation and uprating, the analysis helped to confirm the power output yield of already installed Mini-Hydropower plants. For future estimates based on the Instream Flow Requirement (IFR) policy, the hydrological analysis process uses the Katse Dam Water Surface Elevation (WSE) historical regime and IFR releases. To confirm the overall power generation, this data is used with hydropower plant power determination methods as described in equation 3 [18].

$$P = g * \rho * \eta * Q * H_{net} \dots\dots\dots [3]$$

Whereby:  $P$  is the output power,  $g$  is the gravitational force,  $\rho$  is the water density,  $Q$  is the discharge (flow rate),  $H_{net}$  is an effective head or net head,  $\eta$  is the total plant efficiency (turbine and generator).

#### 3.5.1 Data sources

Katse Dam IFR releases scheduling model-2021 [89] provided the data for this investigation. The compensation valve controls this flow, which is monitored by the flow meter reading along the compensation line. In accordance with the Lesotho Highlands Water Project IFR policy, the downstream daily environmental flow requirements are regulated as a proportion of the daily intake [3].

#### 3.5.2 Data type

The study is based on daily readings of the reservoir level (WSE) and inflow records. The daily flow requirements and, as a result, the maximum power production yield is determined by the IFR releases scheduling model.

#### 3.5.3 Data accuracy and reliability

The records for reservoir levels and compensation discharge span the years 1995 to 2021 [89]. The measured flow and the dam releases rating curves are used to test the accuracy of flow readings. The different discharge penstock intakes, which are operated in proportion to the dam level, assure reliability.

### **3.6 Network stability assessment**

As discussed in Section 2.6 of the literature review, the grid integration option is determined using a computer software package, which is defined as computer programs and related data collecting, utilized in sending instructions to a computer [90]. These programs instruct the computer as to what to perform and when [90]. Among other factors, the software package utilized in this investigation was chosen for its usability, availability, correctness, and relevance to the study.

#### **3.6.1 DigSilent PowerFactory software**

The DigSilent power factory software has been chosen for the possible grid integration of the Katse Dam Mini-Hydropower station. In power systems, the DigSilent program is used to analyse; generation, transmission, and distribution [91], [15]. The software simulates the impacts of grid separation and connection on the plant, allowing protective settings and selection to be made [92]. The software is also used to model the plant's load discrimination before it is implemented. This allows you to evaluate the plant's network stability and synchronization capability without having to build it.

The DigSilent power factory program is used to evaluate the impact of various switching events on network and machine stability. Switching the load on and off, synchronizing with the grid, increasing and decreasing the load are all set events. These events are then utilized to evaluate the machine's electrical torque, rotor angle, and electrical power response, as well as varied bus voltage responses, as detailed in Section 2.6 under stability [62], [68]. This assessment is done in small scale generating plants, because it has a lesser impact on overall network behaviour [93].

### **3.7 Project Economic Appraisal**

Kumar and Rahi present three rehabilitation options. In section 2.6.2, for example, the first option appears to be the most economical and best option for economic reasons. However, it is in the best interests of this study to consider the worst-case scenario. This study considers the scenario of total hydropower equipment replenishment, with the initial installation cost of the components serving as the foundation. As an alternative, the value is discounted to today's value using the consumer pricing index and the compound interest formula.

The energy cost is then calculated using the installation cost, and the approximated specific cost is determined. The firm energy cost is then estimated from the specific cost and

compared to the dam load demand. This determines the project's investment repayment period. As a result, the project's viability is determined based on its current value.

In this chapter, the data collection was guided by literature. A detailed analysis of the available data is covered in the next chapter.

## Chapter 4: Results and Discussions

This chapter expands on the different results which directly address the criteria to arrive at the proposed objectives of the study. The results include the outcome of the plant condition assessment filter, which was conducted using Hydro Asset Trigger (HAT), visual inspection of the plant equipment, equipment testing, and visual inspection of instrumentation. These four are central to this part of the main objective of the study, which is the rehabilitation of the hydropower plant. Since rehabilitation and uprating are mostly tied together, this part further gives the results of the assessment of hydropower resources in order to address the second objective of the study, which verifies the condition of the hydraulic system of the Mini-Hydropower plant. Furthermore, the second objective results in generation capacity increase, which then informs the third objective of the study, which is load extension or grid integration. In order to carry out the process of these results, the chapter is divided into three sections.

The first section presents the results from the assessment conducted on the specific components of the Katse Mini-Hydropower plant for rehabilitation. Therefore, the results for each method have been outlined with specific ratings diagnosing the level of damage to particular components, and for the objective to be met, the results portray the extent of damage to components, showing the need for rehabilitation and the priority ranking.

The second section is on the possibility of an increased power generation of Katse MiniHydropower from 0.5 MW to 1 MW. The results reflect water resources against power duration, taking cognisance of its assurance in both cases.

The study then evaluates options for synchronizing with the national grid, which leads to an assessment of plant stability under various scenarios. The result highlights the impact on the plant, specifically rotor angle stability upon connecting or disconnecting the plant to the grid and/or load variation for small machines.

### 4.1 Results Condition assessment filter

The initial goal was to evaluate the state of plant equipment using the condition evaluation filter, which included the following criteria:

#### 4.1.1 The hydro asset trigger age (HAT)

**Table 7** shows the equipment rating for the Katse Dam Mini-Hydropower plant, as determined by rating evaluation in **Error: Reference source not found** (Chapter 3:

Methodology). The years begin with the installation/commissioning of the Mini-Hydropower plant (1997). The rating is given on a scale of 1 to 10, with "Good" ranging from (1-3) and "1" being best and "3" representing good; "Fair" at (4-6), and "Poor" ranging from (1-6). (710). The range scale is determined by the actual years of installation and their proximity to each threshold.

**Table 7:** Katse Dam Mini-Hydropower Plant Equipment Rapid Assessment Rating.

Plant Subsystems	Katse Dam minihydropower (Commission)Years	Rapid Assessment Rating			Katse Dam minihydropower operating years
		Good (≤)	Fair (≤)	Poor (>)	
<b>Electrical</b>					
Generators	27		4		8.6
Transformers	27		4		8.6
High Voltage Switchgear	27		5		8.6
Auxiliary Electrical Equipment	27		5		8.6
Control Equipment	27		5		8.6
DC Equipment	27			7	8.6
<b>Mechanical</b>					
Francis Turbines	27	1			8.6
Gates	27		4		8.6
Butterfly Valves	27		4		8.6
Auxiliary Mechanical	27		4		8.6
<b>Count Number of Items marked</b>	10	1	8	1	10
<b>Percentages (%)</b>		10	80	10	100

#### 4.1.2 Visual inspection

The equipment condition evaluation at Katse Dam Mini-Hydropower plant was carried out using **Table 6** of the methodology, and the results are shown in **Table 8**. Evaluations are graded using the criteria in Sub-section 3.4.3. of the Methodology.

**Table 8:** Katse Dam Mini-Hydropower Plant Equipment Physical and Structural Condition Assessment.

No	Katse Component	Part	Evaluation			Observation
			A	B	C	
1	<b>Turbine</b>	Runner			1	No signs of cavitation or structural deformation
		Spiral Casing		5		-Differential pressure damaged -Pipework not leaking or corroded.
		Speeder Ring		4		-Links corroded - Servomotor leakages
		Guide Vanes		4		- Corrosion observed on adjusting springs
		Turbine Bearing		6		-Bearings housing not damaged but lubrication system/power pack is damaged
		Shaft		6		-Corroded, and has been in one position for years and may need alignment.
		Governor	9			-Pumps damaged -Hydraulic valves damaged
		Main Inlet Valve		4		-Valve body painting cracked -Seals doubtful
2	<b>Generator</b>	Stator		6		-Burn deposits observed -VTs and CTs damaged -Terminals corroded and dismantled
		Rotor		6		-Burn deposits observed -No excitation
		Guide Bearing		4		-Lubrication damaged
		AVR/Excitation	10			-Completely missing
3	<b>Control and Protection</b>	Control panel	8			-Corrosion Cracked-Locks damaged
		Generator CB			3	-Corrosion signs on CB brackets
		Protection	10			-Relays and electronic water damaged
4	<b>Transformer</b>	Main transformer	9			-Windings burnt -Cooling fan damaged and dismantled -Casing rust eaten
<b>Total Number of Parts Rated</b>			5	9	2	16
<b>Percentage (%)</b>			31.2	56.3	12.5	

#### 4.1.3 Equipment testing

This section contains the results of tests done on generator stator and rotor windings, as well as primary and secondary generator transformer windings. The Megger MIT 515 5kV Insulation Resistance Tester was utilized to conduct the tests. This device is used to measure Insulation Resistance (IR) at various time intervals, and the tests are carried out in accordance with the prescribed technique as outlined in IEEE Standard 43-2013 [84]. These tests are useful for assessing the state of windings when physical inspection is not possible, and they are also used to predict winding insulation problems. It is worth noting that excessive transformer or generator partial discharge might result from insulation breakdown, resulting in complete equipment failure.

The tests are carried out according to the suggested values in **Table 4** and **Table 5**. The measured values for insulation resistance, dielectric absorption ratio, polarization index, and computed polarization index are compared to the measured, in this section. For consistency, the tests were performed on separate days, and the averages are shown from **Table 9** to **Table 14**, along with a summary for each component.

#### 4.1.3..1 Generator Stator and Rotor Tests

**Table 9** below shows the stator winding insulation resistance measured average values in 1 minute and 10 minutes, as well as the polarization index, dielectric absorption ratio, and estimated polarization index. The values measured between windings and windings to earth are shown in the table. All of the IR values are in mega ohms, whereas the PI and DAR are ratios.

**Table 9:** Stator Winding Measured Average Values IR, PI, DAR, and Calculated PI.

Winding	(MΩ) Average IR 1min	(MΩ) Average IR 10min	Average PI	Calculated PI	Average DAR
U1-V1	4.79	4.96	1.12	1.03	1.09
U1-W1	4.29	4.76	1.13	1.11	1.09
V1-W1	3.09	4.29	1.42	1.39	1.27
U1-E	2.21	2.34	1.07	1.06	1.08
V1-E	1.78	2.25	1.35	1.26	1.14
W1-E	1.46	2.07	1.61	1.41	1.36

**Table 10** shows the average values for insulation resistance in 1 minute and 10 minutes, polarization index, dielectric absorption ratio, and estimated polarization index for the rotor winding. The values measured between windings to earth are shown in the table. All of the IR values are in mega ohms, whereas the PI and DAR are ratios.

**Table 10:** Rotor Winding Measured Average Values IR, PI, DAR and Calculated IR.

Winding	(MΩ) Average IR 1min	(MΩ) Average IR 10min	Measured Average PI	Calculated PI	Measured Average DAR
W1-E	11,165	14,475	1,345	1,30	1.10
W2-E	34,05	40,4	1,205	1,19	1.22

The results of tests performed on the stator and rotor windings are summarized in **Table 11**. The polarity index value is the average of three generator stator windings and two generator rotor windings, plus the polarity index results between the windings and the earth. The values of PI in Table 21 indicate that the insulation of the windings is in doubtful condition, as shown in **Table 5**. The DAR values in Table 21 confirm the PI's findings, indicating that the generator stator and rotor windings are in poor condition, refer to **Table 4**.

**Table 11:** Generator Result Summary and Rating.

Generator	IR 1min	IR 10min	PI (Measured)	PI (Calculated)	DAR	Rating		
						Good	Fair	Poor
Stator	2.94 MΩ	3.44 MΩ	1.28	1.21	1.20			8
Rotor	28.01 MΩ	33.44 MΩ	1.24	1.22	1.13			8
Equipment Rating								8

#### 4.1.3..2 Generator Transformer Tests

**Table 12** shows the measured average values for insulation resistance in 1 and 10 minutes, polarization index, dielectric absorption ratio, and computed polarization index for the primary winding. The values measured between the windings to the ground are shown in the table. The IR values are all in mega ohms, although the PI and DAR values are ratios.

**Table 12:** Primary Side Winding Measured Average Values IR, PI, DAR and Calculated PI.

Winding	Average IR 1min (MΩ)	Average IR 10min (MΩ)	Average PI (Measured)	PI (Calculated)	Average DAR
L1-E	61,05	65,8	1,08	1,08	1.04
L2-E	65,9	65,5	0,99	0,99	1.02
L3-E	65,3	66,1	1,015	1,01	1.01

**Table 13** shows the measured average values for insulation resistance in 1 minute and 10 minutes, polarization index, dielectric absorption ratio, and computed polarization index for the transformer secondary winding. The values measured between windings are shown in the table. All of the IR values are in kilo ohms, while the PI and DAR are ratios.

**Table 13:** Secondary Side Measured Average Values IR, PI, DAR and Calculated PI.

Winding	Average IR 1min (kΩ)	Average IR 10min (kΩ)	Average PI (Measured)	PI (Calculated)	Average DAR
L1-L2	17,06	19,76	1,24	1,16	0.92
L2-L3	17,72	19,245	1,09	1,09	1.03
L3-L1	21,99	21,825	0,95	0,99	0.89

**Table 14** shows the results of the transformer testing. The values of DAR and PI indicate that the transformer winding condition is doubtful and poor, respectively (**Table 4** and **Table 5**). Because these values are beyond the permitted IR values for the respective voltage rating of the winding, the results of the secondary winding insulation resistance add to the results of the DAR and PI, indicating a faulty winding.

**Table 14:** Transformer Result Summary and Rating.

Transformer	IR 1min	IR 10min	PI (Measured)	PI (Calculated)	DAR	Rating		
						Good	Fair	Poor
Primary	64.08 MΩ	65.8 MΩ	1.03	1.03	1.02			9
Secondary	18.92 kΩ	20.28 kΩ	1.09	1.08	0.95			10
Equipment Rating								9.5

#### 4.1.3..3 Governor Hydraulic System

In addition to equipment testing, the governor hydraulic system oil tests are performed in accordance with the methodology guide, with the results shown in **Table 15**. The water content occupied 88.2% of the sampled oil, 5 particle Quantifier Index (QI), viscosity values were too few to plot, and oil particle count revealed no abnormal contamination, according to the results of the four parameters evaluated.

**Table 15:** Governor Hydraulic System Oil Test Results.

Standard	Oil Properties to be tested for	Results
ISO 3104	Viscosity	Too few values to plot in cSt at 40 °C.
ISO 6743-5 / ISO4406:99	Element analysis – Particle Quantifier Index	5 PQ Index
ISO 8068 (ISO VG 32 & 46)	Water Content- Cumulative Particle Count/ml	88.2 %
ISO4406:99	Oil Particle Count	A microscopic particle examination of particles filtered from the oil revealed no abnormal contamination

#### 4.1.3..4 Turbine, Generator Gearbox and Bearings Lubrication and Cooling

Oil tests for bearings and hydraulic systems are also performed as explained in the methodology section, with the results provided in **Error: Reference source not found**. The findings of four properties evaluated show: The water content of the measured oil was 90.5%, 5 particle quantifier index, viscosity data were too few to plot, and debris analysis revealed indications of coarse dirt ingress for oil particle count.

**Table 16:** Guide Bearings and Generator Gearbox Hydraulic System Oil Test Results.

Standard	Oil Properties to be tested for	Results
ISO 3104	Viscosity	Too few values to plot in cSt at 40 °C.

ISO 6743-5 / ISO4406:99	Element analysis – Particle Quantifier Index	5 PQ Index
ISO 8068 (ISO VG 32 & 46)	Water Content- Cumulative Particle Count/ml	90.5 %
ISO4406:99	Oil Particle Count	Debris analysis revealed evidence of coarse dirt ingress

#### 4.1.4 Instrumentation

The Mini-Hydropower plant components instrumentation was examined and found to have no substantial inconsistencies in display, as shown in **Table 17**.

**Table 17:** Katse Dam Mini-Hydropower Plant Components Instrumentation Results.

Component	Instrumentation	Reason	Results
Transformer	Temperature monitoring	To control cooling fan and activate protection, and to a remote monitoring	Temperature devices displayed room temperature (16°C)
Generator	Voltage, current and power monitoring.	To give feedback to control and protection (governor)	Instrumentation transformers show major signs of fatigue.
Bearings	Temperature monitoring Pressure Monitoring	To give feedback to oil hydraulic pumping unit.	Temperature devices displayed room temperature (13°C) and the pressure displayed 0 psi.
Governor	Temperature monitoring Pressure Monitoring	To give feedback to governor oil hydraulic power pack for control and protection.	Temperature devices displayed room temperature (13°C) and the pressure displayed 0 psi.
Turbine system	Pressure Monitoring Temperature monitoring	To give feedback to turbine control system and protection of turbine assembly.	Pressure gauges balanced at 0 psi across the system, temperature monitoring at 13°C dead plant.

#### 4.1.5 Condition Assessment Filter

**Table 18** depicts the micro hydropower plant components, as well as the specific elements of each component, as they are exposed to various suitable filters to produce findings from which a rehabilitation decision is made. Each component score from multiple filters is

provided in order to generate the overall score of the component of these results, which is based on the rating scale shown in **Table 18**. The equipment condition evaluation rating is assigned to each filter depending on the extent of flaws, age, or result.

**Table 18:** Katse Dam Mini-Hydropower Plant Equipment Condition Assessment Filter and Rating.

No	Component	Part	Filters				Total	Maximum	%
			HAT	VI	ET	EI			
1	Turbine	Runner	1	1		1	3	30	10
		Spiral Casing	4	5		1	10	30	33
		Speeder Ring	4	4			8	20	40
		Guide Vanes	4	4		1	9	30	30
		Turbine Bearing	4	6	9	4	23	40	58
		Shaft	4	6			10	20	50
		Governor	4	9	8	4	25	40	63
		Main Inlet Valve	4	4		1	9	30	30
2	Generator	Stator	4	6	8	4	22	40	55
		Rotor	4	6	8		18	30	60
		Guide Bearing	4	4	9	8	25	40	63
		AVR/Excitation	5	10		4	19	30	63
3	Control and Protection	Control panel	5	8			13	20	65
		Generator CB	5	3		1	9	30	30
		Protection	5	10		7	22	30	73
4	Transformer	Main transformer	4	9	9	8	30	40	75

**Figure 2:** illustrates each component condition:

- Turbine – parts of the turbine; runner and guide vanes are generally good as per filter ratings, while spiral casing, speeder ring, bearings and shaft are rather fair.
- Generator – the stator is marginally fair while rotor, guide bearings and AVR/excitation are poor.
- Control and protection – the generator circuit breaker fair but control systems and protection are poor.
- Main transformer - the transformer is extremely poor.

The condition assessment filter's results indicate that some of the components require refurbishment. 6.25% of the plant's key components are still good, while 50% are rated fair. The primary transformer, followed by protection, accounts for 43.75% of the defective components. Control systems, governor systems, guide bearings, and AVR/excitation, on the other hand, were severely damaged. Although the stator and rotor condition are alarming, the 43.75% is terrible.

These findings indicate that the primary elements of the Mini-Hydropower plant's electrical generating component have been severely damaged, necessitating immediate rehabilitation.

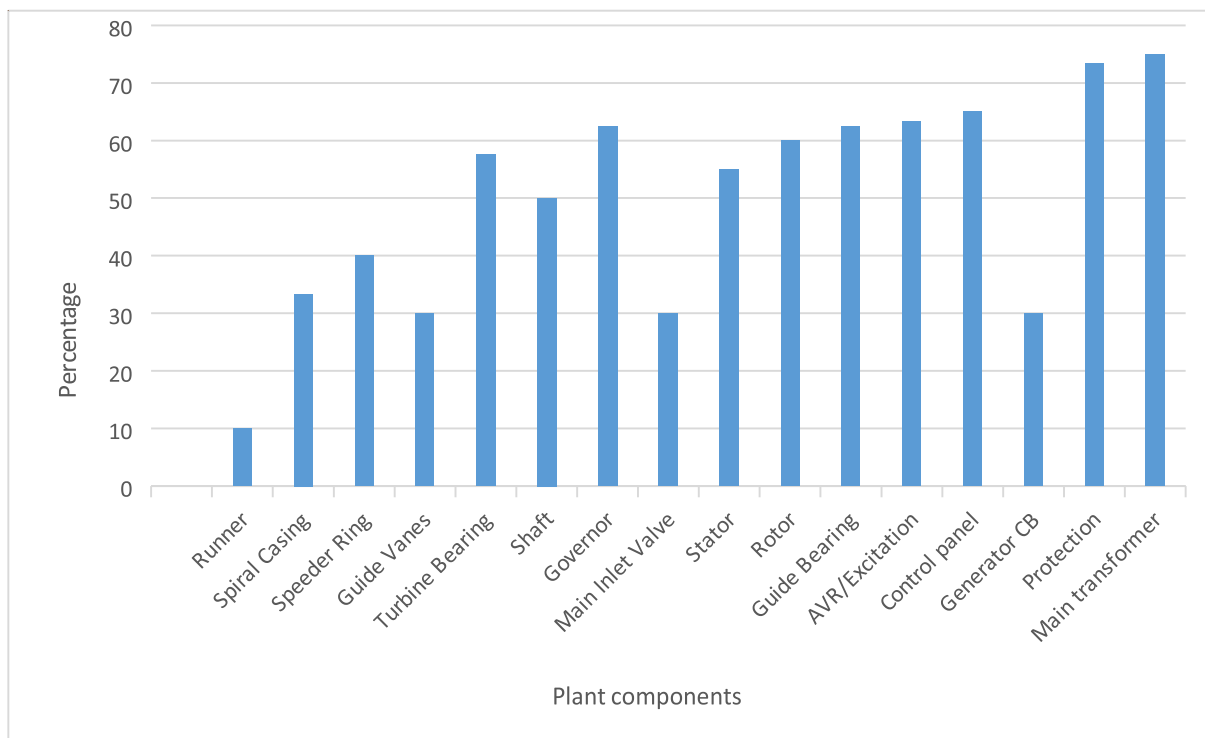

**Figure 2:** Katse Dam Mini Hydro Plant Condition Assessment Rating Graph.

#### 4.2 Results: Resource Assessment

The second goal is to determine the feasibility of raising the micro hydropower plant's generation capacity, often known as plant uprating [17], [16]. The plant uprating evaluates if existing resources may support an additional unit without requiring major civil structural changes. This is accomplished by analysing and developing the flow duration curves of the following:

- Katse Dam compensating system Discharge versus Assurance;
- Katse Dam Compensation System: Assurance vs. Head.

The Katse Dam compensating method Power Potential as a function of Assurance is then calculated and determined.

The historical Katse Dam downstream environmental discharges discharge and the dam water surface elevation were utilized to determine the flow duration curve. The Mini-Hydropower head is calculated from the water surface elevation. Based on this historical information, the power potential is computed. The goal is to compare the present 500 kW power potential to the new 1000 kW power potential. These tests are carried out to ensure that the extra unit can be accommodated without requiring any changes to the civil framework.

The LHWP's IFR policy [3], [94], guides the Katse Dam downstream flow releases (used in the assessment). Controlled flows are therefore created. **Figure 3** to **Figure 7** show the outcomes.

#### 4.2.1 Discharge duration assurance

For the years 1995-2021, **Figure 3** depicts the Katse Dam compensation system Discharge as a function of Assurance. The maximum discharge of 1.5 m<sup>3</sup>/s was equaled or exceeded 8% of the time, whereas the flow of 0.8 m<sup>3</sup>/s was equaled or exceeded more than 50% of the time. The greatest exceeded/equalized flow over this period is 0.2 m<sup>3</sup>/s, which represents the design minimum flow, with more than 98% exceedance.

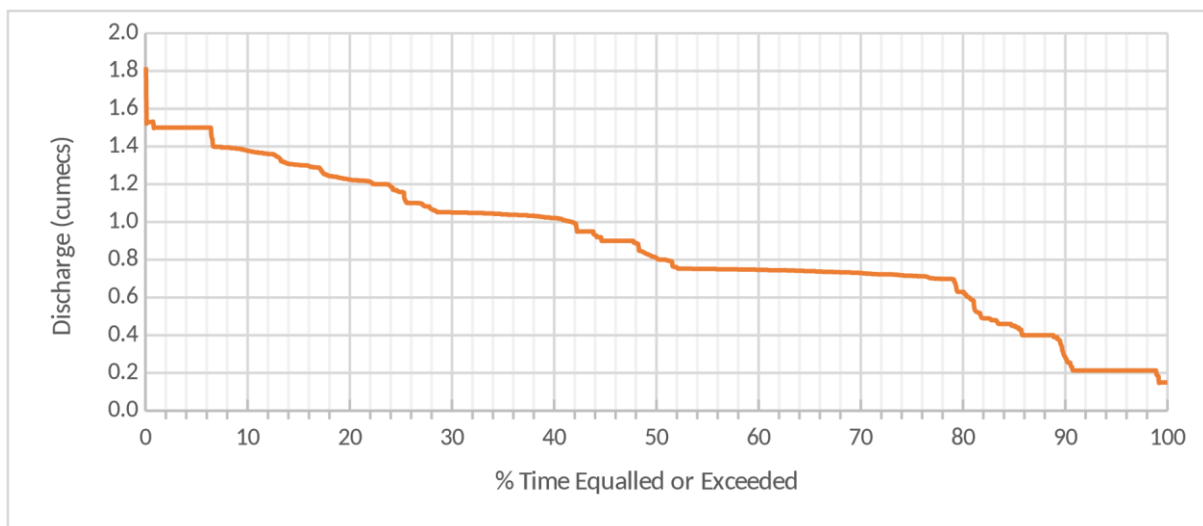

**Figure 3:** Katse Dam Compensation System Discharge versus Assurance for the period 1995-2021.

#### 4.2.2 Head Duration Assurance

**Figure 4** depicts the Katse Dam compensation system Head versus Assurance for the period 1995-2021. The maximum head of 155 meters was equaled or exceeded 10% of the time, while the head of 130 meters was equaled or exceeded 75% of the time. During this time, the minimum design head of 89.3 m was exceeded/equaled by more than 98%.

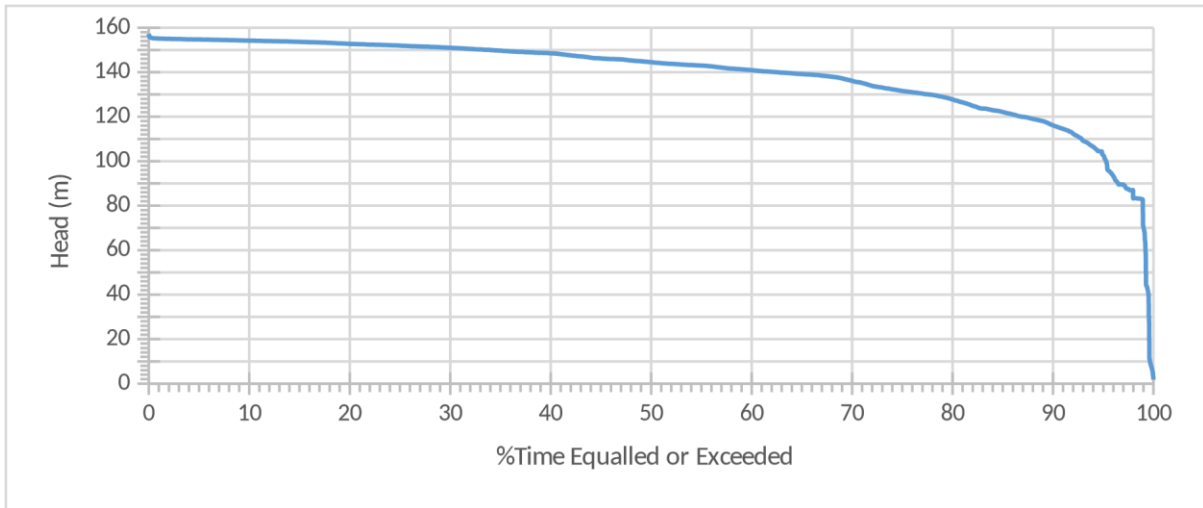

**Figure 4:** Katse Dam compensation System Head versus Assurance for the period 1995-2021.

#### 4.2.3 Power duration assurance

The Katse Dam compensating system Power Potential Discharge as a function of Assurance is shown in **Figure 5**. As illustrated in **Figure 5**, a single machine configuration produces 500 kW, 84% of the time at a flow rate of 0.46 m<sup>3</sup>/s, while a two-machine configuration produces 1000 kW at a total flow of 0.8 m<sup>3</sup>/s at 51% exceedance.

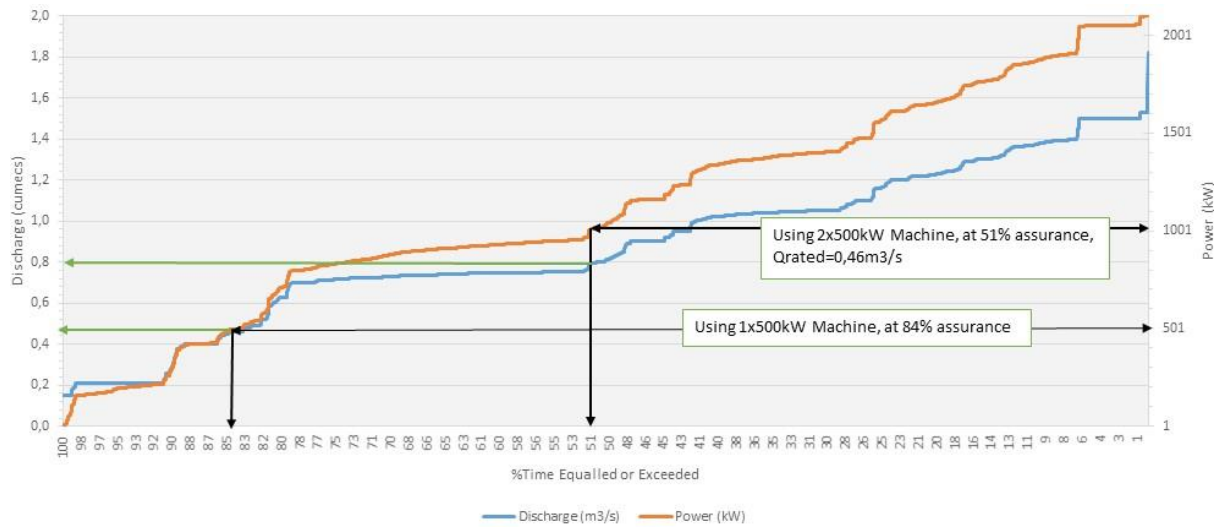

**Figure 5:** Katse Dam compensation system Power Potential, Discharge versus Assurance 1995-2021.

**Figure 6** shows the Katse Dam compensating system Power Potential Head versus Assurance. As illustrated in, **Figure 6** a single machine configuration at the 123 m head generates 500 kW for 84% of the time, while a configuration of two machines yields 1000 kW at the total head of 146 m for 53% of the time throughout this period.

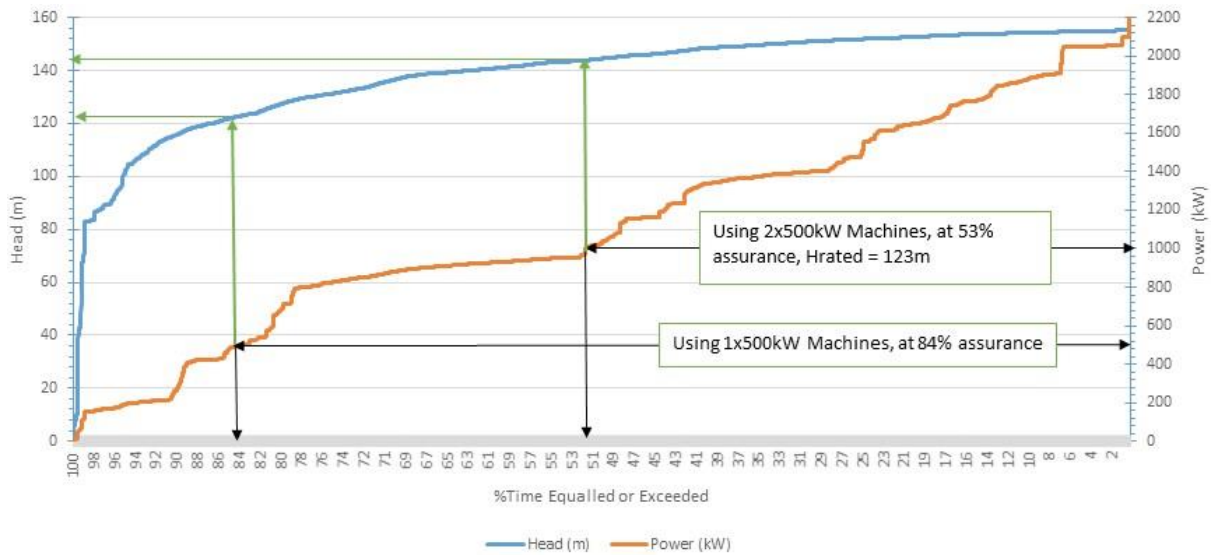

**Figure 6:** Katse Dam Compensation System Power Potential, Head versus Assurance for the period 1995-2021.

**Figure 7** depicts the Katse Dam compensation system Power Potential as a function of Assurance, which shows that one machine configuration generates 500 kW for 84% of the time, two machines generate 80% of total power for 79% of the time, and 1000 kW is equalled or exceeded 51% of the time during this period. With two machines, this scenario yields an average power of 800 kW generated at plus 26% of maximum capacity generation exceedance, producing an 80% capacity factor.

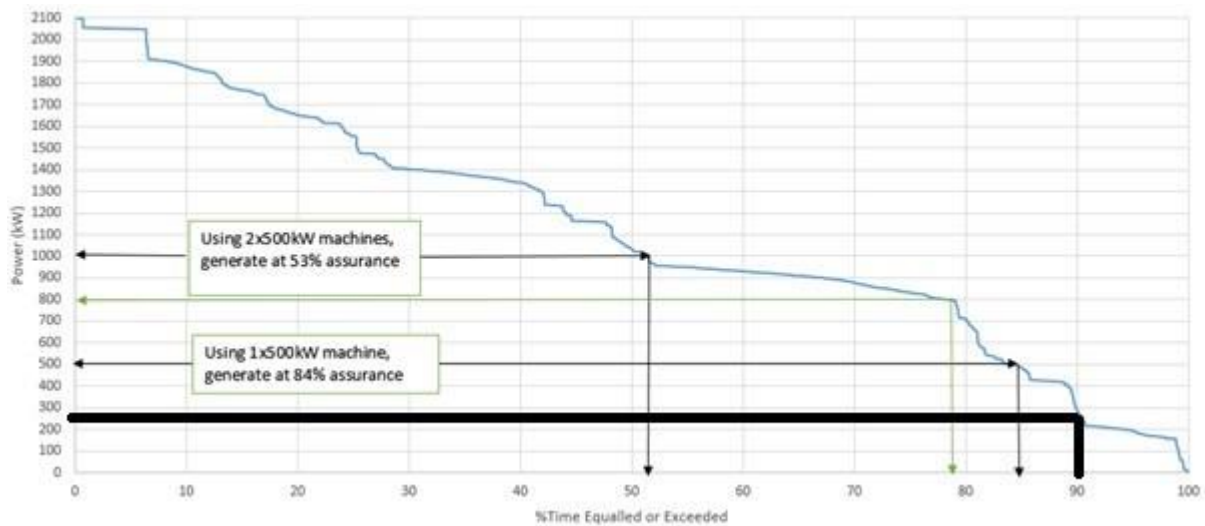

**Figure 7:** Katse Dam compensation system Power Potential versus Assurance for the period 1995-2021.

#### 4.2.4 Summary: Resource assessment

**Table 19** summarizes the hydrological resources of the Katse Dam compensation system. The findings show a correlation between the system design parameters and actual historical discharge, head, and power potential. The system's minimum flow of  $0.2 \text{ m}^3/\text{s}$  necessitates a net head of 108.5 m to create 204 kW with 93% surety, and the minimum head produces 168 kW for 96% of the time, while the design head produces 285 kW with  $0.28 \text{ m}^3/\text{s}$  for 90% of the time. With a rated discharge of  $0.5 \text{ m}^3/\text{s}$  and a net head of 123 m, the machine provides the rated power for 84% of the time.

**Table 19:** Katse Dam Compensation System Hydrological Resources Summary.

Net Head (m)	Compensation Discharge ( $\text{m}^3/\text{s}$ )	Power Potential (kW)	% Assurance
123	$Q_d = Q_{\text{rated}} = 0.5$	$P_{\text{rated}} = 500$	84
108.5	$Q_{\text{min}} = 0.2$	204	93
Rated $H_n = 115$	0.28	285	90
Min $H_n = 89.3$	0.21	168	96

#### 4.3 Stability assessment

The final goal of the study, as mentioned in Sub-section 3.1.1 of the methodology, is discussed in this part. The literature confirms that rehabilitation and uprating are mutually beneficial, necessitating consideration of expanded power dispatch options. Connecting the plant to a larger load introduces new considerations for plant stability. In this section, the machine and network responses to various switching events are presented.

Figure 8 is a DigSilent model of the Katse Dam Mini-Hydropower synchronous machine and network connectivity topology. The switching events are constructed according to the scenarios described in the methodology chapter, and representative reaction curves may be seen in graphs, on Figures 19 through 25, indicating a response to the specified event.

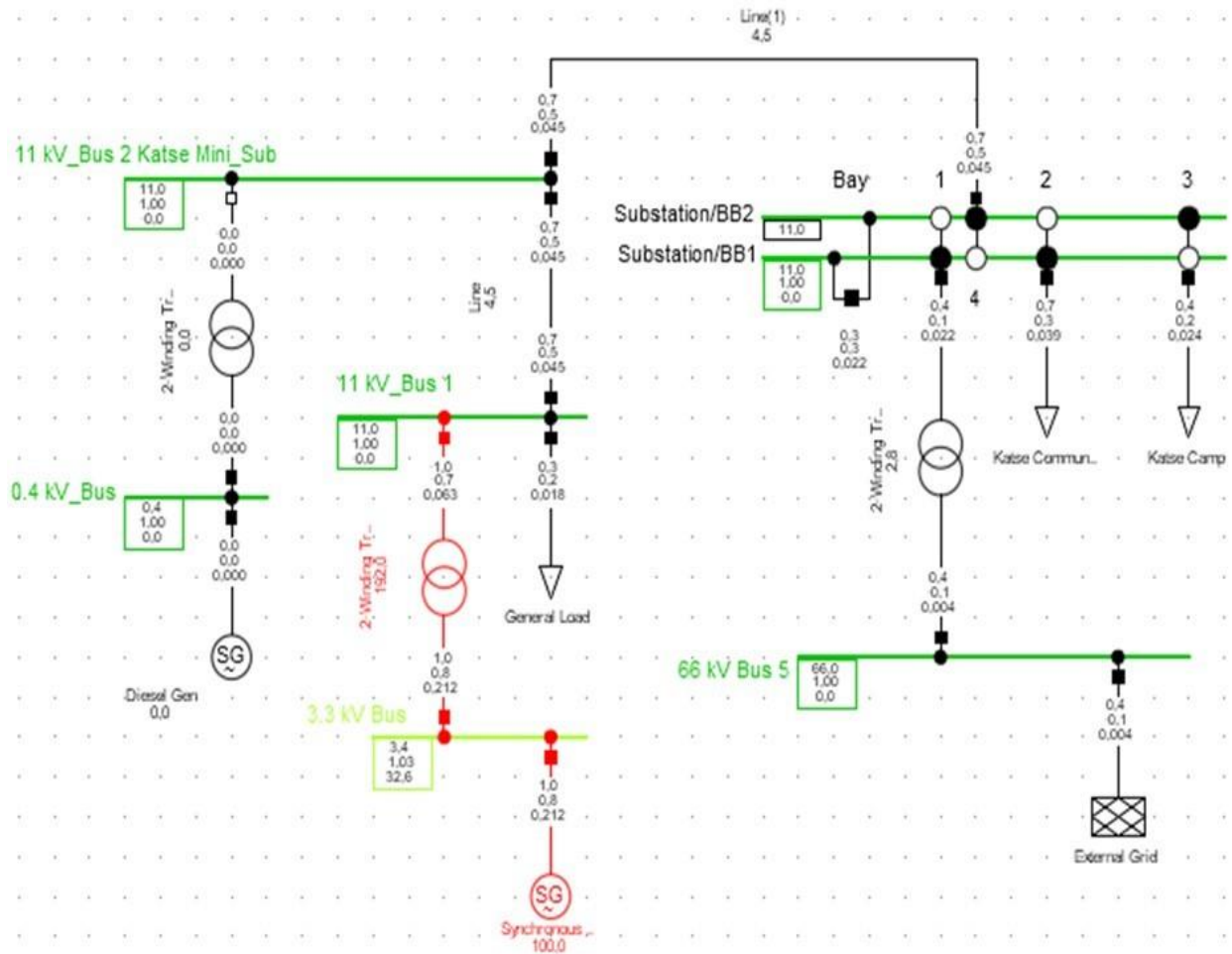
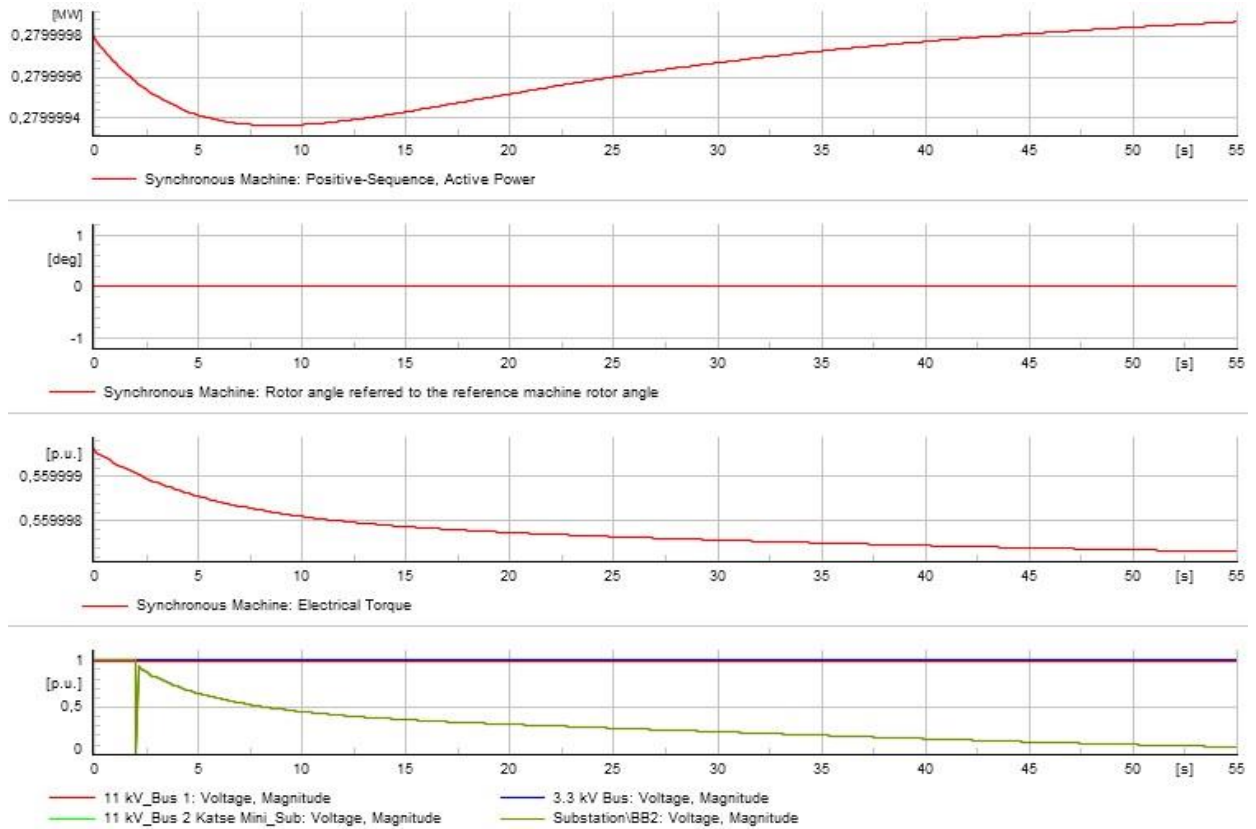

**Figure 8:** Katse Dam Network Model

The graphs demonstrate the positive-sequence active power of a Mini-Hydropower (synchronous machine), rotor angle compared to the reference machine rotor angle, electrical torque, and voltage magnitude among four cascading buses for each event. In the following paragraphs, the observations are discussed as thus:

#### 4.3.1 Mini-Hydropower (1 unit) response to switching event (dam load only).

**Figure 9** shows a single Mini-Hydropower plant connected to the Katse Dam auxiliary systems load (rated 280 kW). Within 55 seconds, the active power reaches full load supply after briefly dropping to 0.2799994 MW in the first 10 seconds, the rotor angle remains at 0°, electrical torque retards and remains below 0.559998 pu within 55 seconds, the three local bus voltages remain at 1 pu, and the main bus/grid voltage drops to '0' within 55 seconds in response to the switching event.



**Figure 9:** Single Machine Mini-Hydropower Response on Dam Load Only.

#### 4.3.2 Mini-Hydropower (1 unit) response to grid loss switching event (dam and camp load).

The single machine Mini-Hydropower response to the dam and camp load (280+430 kW) is shown in **Figure 10** with grid loss within 3 seconds. Active power spikes to 1.2 MW and drops below 0.16 MW, the rotor angle shifts from 36 ° to 0 °, electrical torque spikes to 2.4 pu then falls to 1 pu, and bus voltages drop to 0.1 pu, which is outside the 6% stability limit.

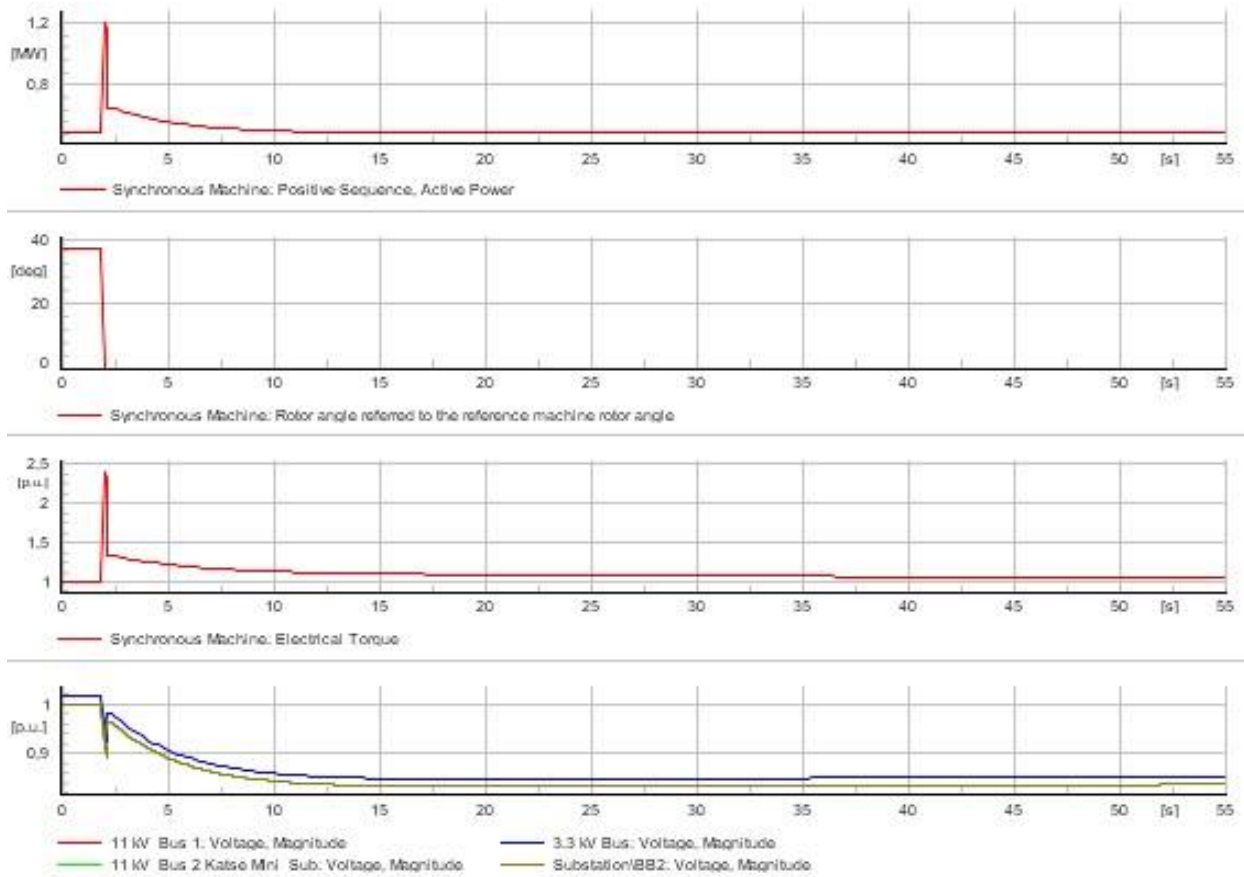

**Figure 10:** Single Machine Mini-Hydropower Response on Dam and Camp Load.

#### 4.3.3 Mini-Hydropower (2 units) response to switching event (dam and camp load)

**Figure 11** shows a two-machine Mini-Hydropower response to the dam and camp load (280+430 kW) with grid loss within 3 seconds. Active power spikes between 1.44 MW and 0.6 MW before normalizing to 0.96 MW in 10 seconds, rotor angle changes from 36 ° to 0 ° in 10 seconds, electrical torque spikes to 1.44 pu before normalizing to 1.12 pu in 10 seconds, and bus voltages rise to 1.44 pu.

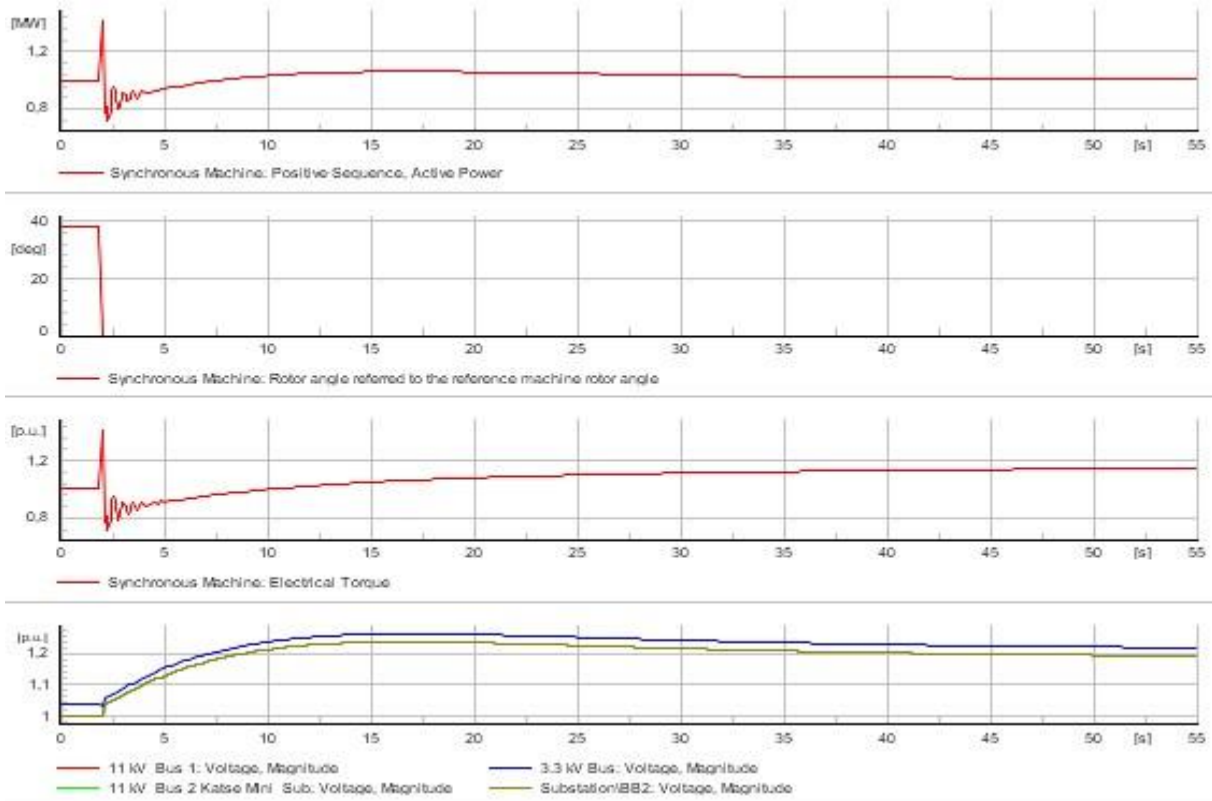

**Figure 11:** Two Machines Mini-Hydropower Response \_Load Dam + Camp.

#### 4.3.4 Mini-Hydropower (1 unit) response to load increase and decrease (dam only).

A switching event for a minor increase in Mini-Hydropower single machine generation setpoint of 3 seconds with dam load only is shown in **Figure 12**. The related responses show rotor angle remaining at  $0^\circ$ , active power following the increase to 0.33 MW within 3 seconds and normalising to 0.28 MW, electrical torque changing from 0.55 pu to 0.7 pu and normalising at 0.59 pu after 3 seconds, and local bus voltage experiencing a minor decrease to 0.9 pu while the grid is totally falling to zero because it is switched off.

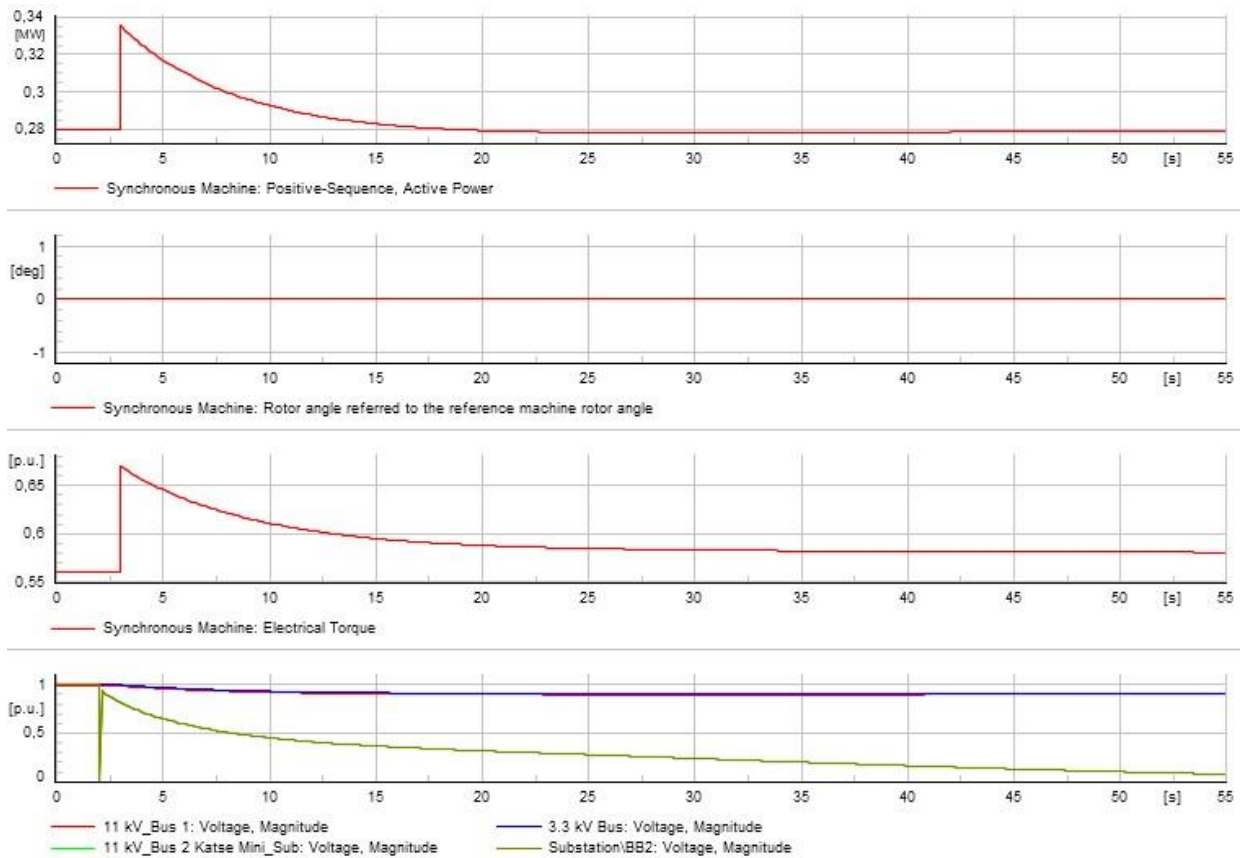

**Figure 12:** Single Machine Response with Dam Load increasing in 3 seconds.

A 3 second switching event showing the Mini-Hydropower single machine generation setpoint decrease with dam load only is shown in **Figure 13**. The related response shows rotor angle undistorted at  $0^\circ$ , active power dipping to 0.29 MW and normalising to 0.34 MW within 7 seconds, electrical torque changing from 0.29 pu to 0.7 pu and normalising at 0.65 pu after 7 seconds, and local bus voltage experiencing a minor increase to 1.1 pu while the grid is totally falling to zero because it is switched off.

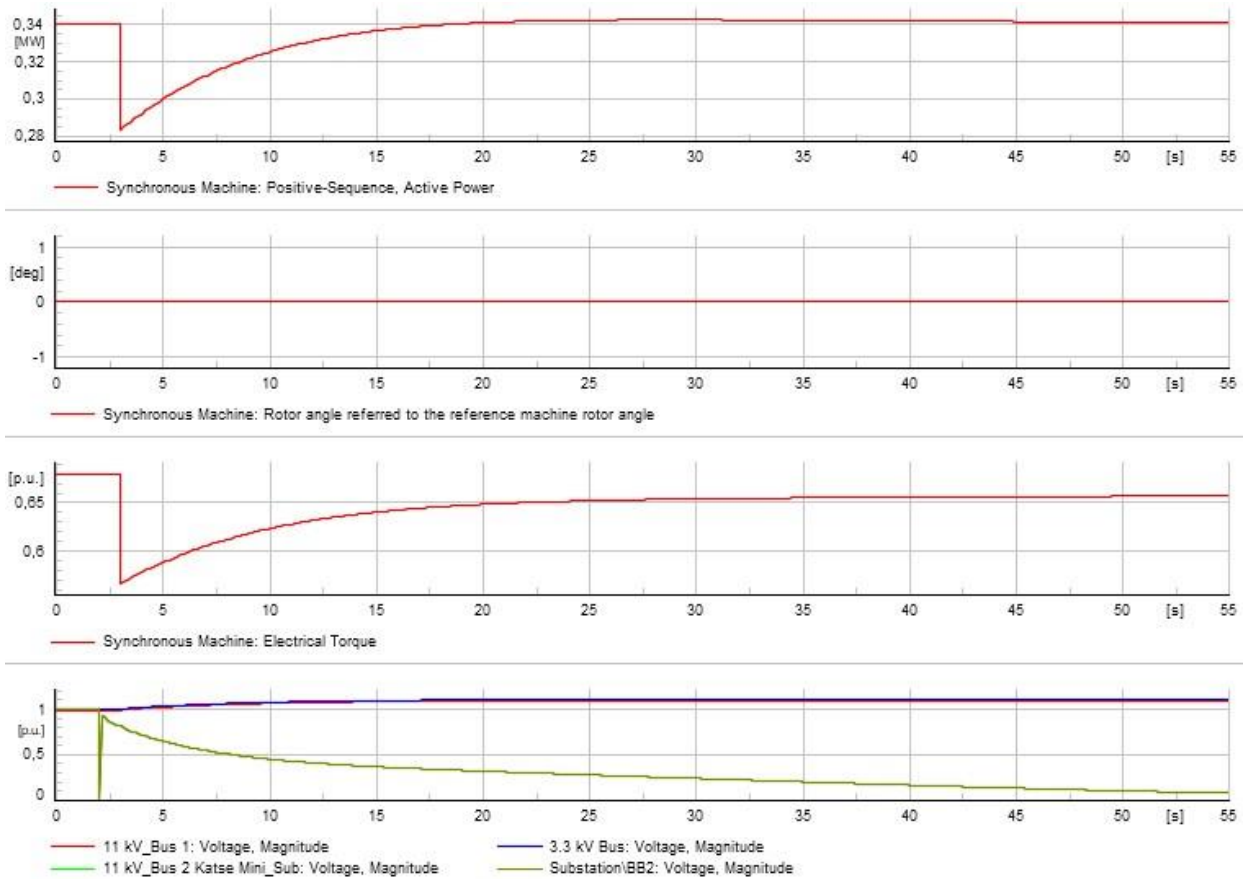

**Figure 13:** Single Machine Response with Dam Load decreasing in 3 seconds.

#### 4.3.5 Mini-Hydropower (2 units) response to load increase and decrease (dam & camp).

**Figure 14** shows a 3 second switching event for two Mini-Hydropower units synchronising to the grid with dam and camp load increasing in 3.5 seconds. The system response provides; At the rotor angle, a magnitude  $90^\circ$  distortion occurs between 4 and 5 seconds, the electrical torque experiences distortion for 1 second between (-) 3 and 7 pu and normalizes at 5 seconds, and active power varies between (-) 3.2 and 3.2 MW before stabilizing at 0.75 MW after 5 seconds.

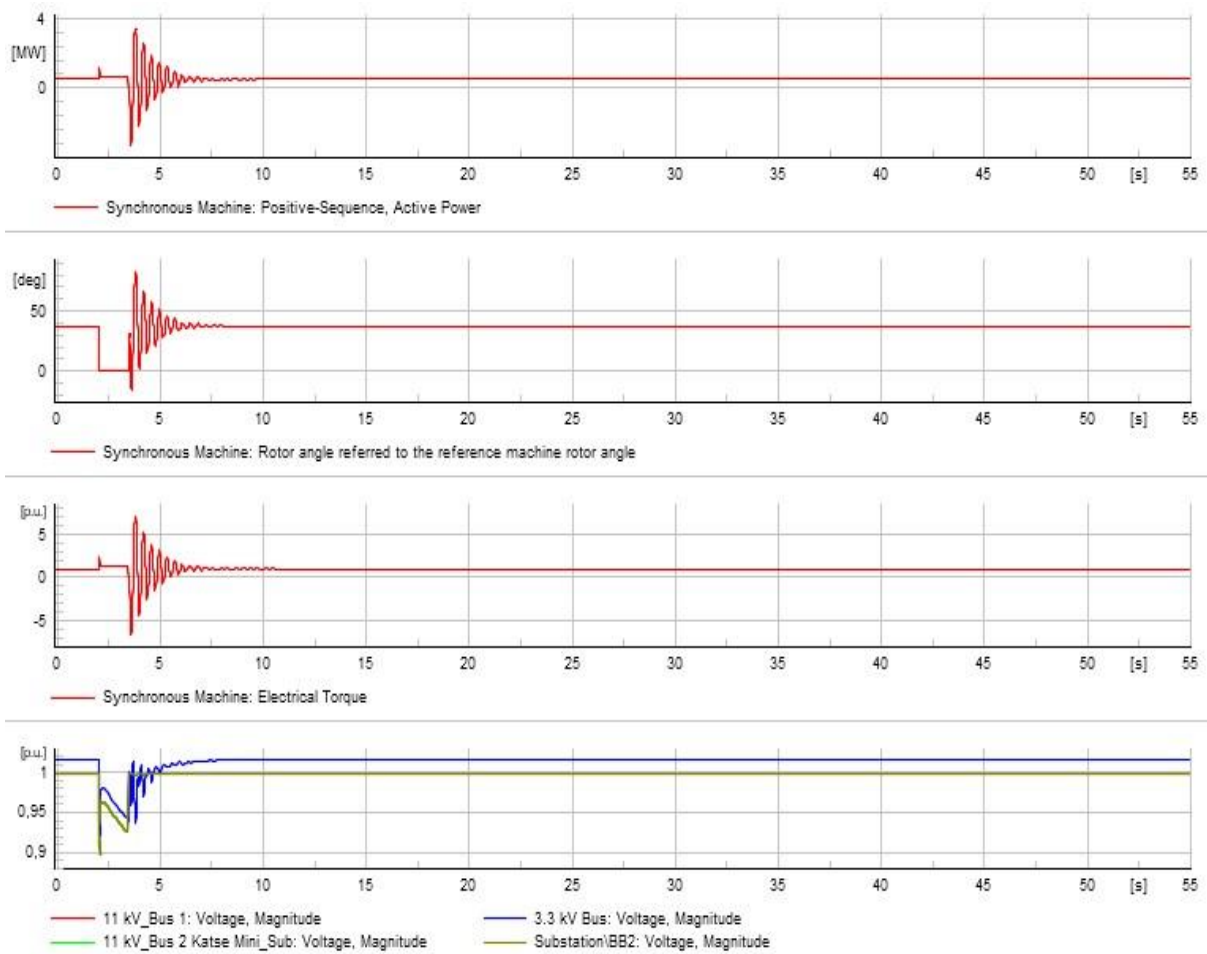

**Figure 14:** Two Mini-Hydropower units Response with Dam and Camp Load and Grid Synchronising within 3sec and Load increase in 3.5 sec.

As depicted in **Figure 15**, there is a 3 second switching event for two Mini-Hydropower machines synchronising to the grid, with dam and camp load decreasing after 3.5 seconds. The system response is as follows: active power varies between (-) 1.5 and 3.5 MW and stabilizes at 0.75 MW after 5 seconds; generator switchgear bus voltage hunts for 2 seconds between 1.03 pu and 1.15 pu and stabilizes at 1.04 pu; load bus voltage spikes between 1 pu and 1.1 pu for 2 seconds and normalizes at 1 pu; rotor angle drops from 40° to 0° for the first 2 seconds and spirals from 0° to 60° for the next 2 seconds.

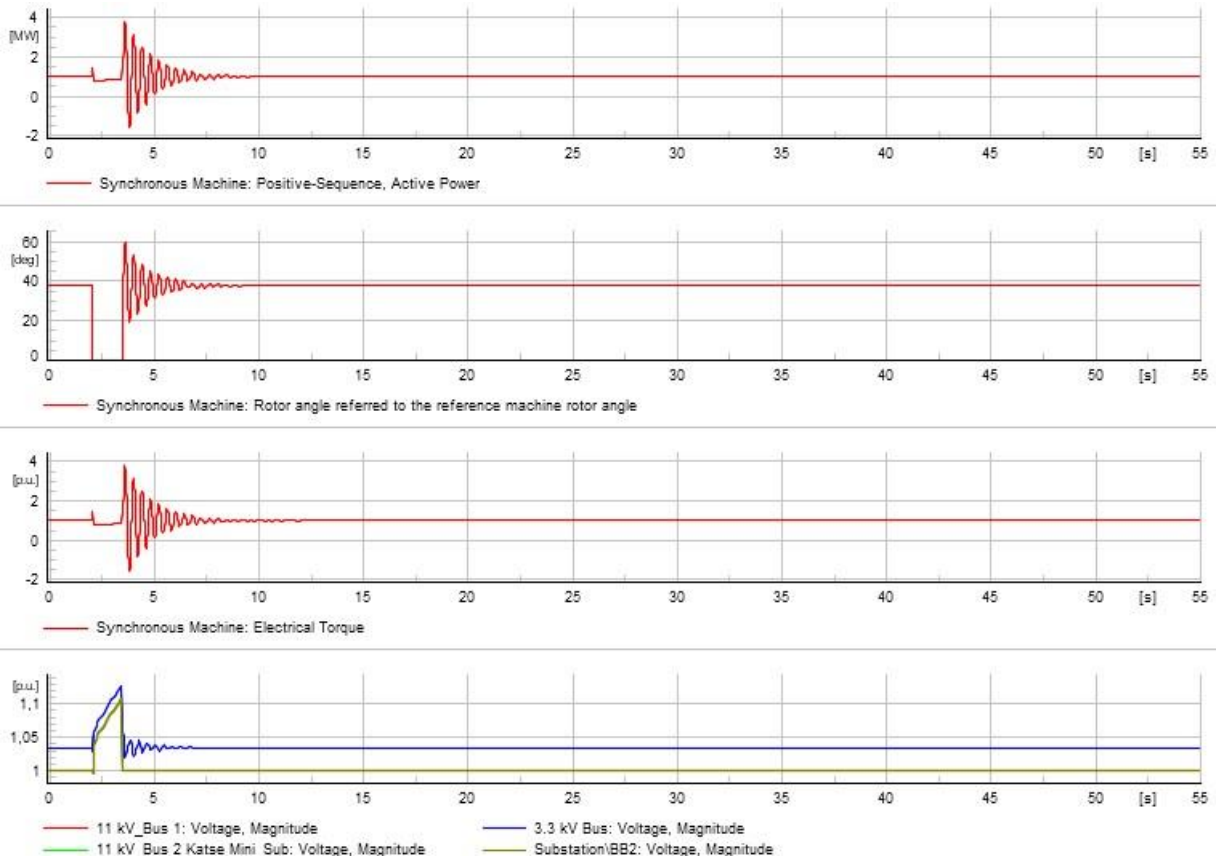

**Figure 15:** 2 MH Response with Dam and Camp Load and Grid Synchronising within 3sec and Load increase in 3.5 sec.

#### 4.4 Project Economic Appraisal

Installation costs for the Katse Dam Mini-Hydropower plant in 2022 are shown in **Table 20**, and are converted from original 1995 installations. Based on the South African inflation timeline from 1995 to 2022, the average annual inflation rate was 5.42%, with 1995 consumer price index (CPI) at 33.3 and 2022 CPI at 138.43 [95], [96]. Today's value is then

calculated as:  $Value_{today} = Value_{1995} \times \frac{CPI_{today}}{CPI_{1995}} = 1 \times 33.3 \times \frac{138.43}{33.3} = R\ 4.16 = \$\ 0.26$ , alternatively using compound interest formula;  $FV = PV \times (1+i)^n$ , where FV is future value, PV is present value,  $i$  is interest rate and  $n$  is number of times the interest is compounded, this then gives  $value_{2022} = 1 \times (1+0.0542)^{27} = R\ 4.16 = \$\ 0.26$  [95].

**Table 20:** Katse Dam Mini-Hydropower Plant Installation Costs 2022

<b>Mechanical</b>
-------------------

<b>Description</b>	<b>Amount \$</b>
Turbine including governor, spiral case, guide vane actuator, flywheel and draft tube	119673.3
Governor system	45807.18
Main inlet valve	7249.883
Draft tube valve	9403.63
Synchronous generator with control gear	152061.5
Overhead travelling crane, expansion joint, steelworks, specified spare parts	31347.74
<b>Subtotal Mechanical</b>	<b>365543.2</b>
Delivery and Installation (Transport, storage, erection, tests, manuals & Training)	28484.23
<b>Electrical</b>	
Remote control	10617
Generator auxiliary transformer	12133.84
Generator unit transformer	24570.78
3,3 kV Switchgear	25784.15
Electrical auxiliaries including 380 V auxiliary board, 110 V DC Auxiliaries Board and Inverter ventilation, fire protection, cabling etc.	41557.98
<b>Subtotal Electrical</b>	<b>114663.7</b>
Delivery and Installation (Transport, storage, erection, tests, manuals & Training)	60061.96
<b>Sub Total Material</b>	<b>480206.9</b>
<b>Sub Total Delivery and Installation</b>	<b>88546.19</b>
<b>TOTAL</b>	<b>568753</b>

#### 4.4.1 Capital Cost

Only 6.25% of the plant components remain in good health, according to the data in Subsection 4.1.5, **Figure 2**. The results give the complete overhaul requirement for the plant, therefore capital cost estimations are based on the initial installation cost. The budget cost estimates for the second unit installation are summarized in 4.4.2.

#### 4.4.2 Electro – Mechanical components

This covers the provision of:

- 2 x 500 kW turbines and related equipment
- Auxiliaries for generators and accessories
- Control and protection for transformers
- Commissioning and installation

**Table 20** shows the current cost of a single unit electro-mechanical plant, installation, and commissioning, which is \$ 568.8k (converted from 1995 value by \$ 0.26), and \$ 1.13M for two units.

#### Specific Cost

Approximated specific cost in USD/kilowatt is \$ 1.13M/1MW, \$ 1130/kW, based on construction costs only [97].

#### Plant Energy Projections – Firm and Non-Firm

The energy forecasts for Mini-Hydropower plants are determined as follows:

$$E = (\text{capacity}) \times (\text{availability}) \times (\text{operational hours});$$

The economic life period is estimated to be 25 years with a plant availability factor of 90% based on **Figure 7**, where plant capacity is picked from the graph in **Figure 7** under specified capacity factor, and power at 90% water availability is 285 kW [98]. 1 MW of power may be generated 51.0% of the time. As a result, the firm and non-firm energy are computed as follows:

$$\text{Firm Energy: } 0.9 \times 0.9 \times 285 = 230.85 \text{ kWe or}$$

$$0.9 \times 0.9 \times 285 \times 24 \times 365 = 2.02 \text{ MWh/year}$$

$$\text{Load factor equivalent} = 230.85/1000 \times 100 = 23\%$$

$$\text{Non-Firm Energy: } 0.9 \times 0.51 \times 1000 = 459 \text{ kWe or}$$

$$459 \times 8760 = 4.02 \text{ MWh/year}$$

$$\text{Load factor equivalent} = 459/1000 \times 100 = 46\%$$

$$\text{Total Energy approximated: } 0.9 \times 0.51 \times 1000 + 0.9 \times (285 + 1000)/2 \times 0.39 = 684.52 \text{ kWe or}$$

$$684.52 \times 8760 = 6 \text{ MWh/year}$$

$$\text{Load factor equivalent} = 684.52/1000 \times 100 = 68\%$$

#### 4.4.3 Economic Analysis

**Table 21** summarizes the Katse Dam rehabilitation economic analysis. The energy from three power plant scenarios in 4.4.2 is utilized to estimate project viability and investment payment period. The capital cost only includes the construction expenditure and does not include operating and maintenance costs.

**Table 21:** Katse Dam Economic Analysis Summary.

	Energy (MWh)	Percentage	Cost (Thousand USD)	Savings	Repayment Period (Years)
<b>Annual Consumption</b>	<b>3,76</b>		<b>238.5</b>		
Firm Energy	2,02	54%	128.8	-109,7	8,8
Non-Firm Energy	4,02	107%	255.3	16.7	4,4
Total Energy	6	160%	381.7	143.1	3,0
<b>Capital Cost</b>			<b>1130</b>		

**Table 21** above shows that the yearly average consumption of the auxiliary systems is 3.76 MWh/year, with an annual cost of \$ 238.5 thousand. The plant capacity contributes 54% of yearly energy demand, resulting in a \$ 128.8 thousand energy savings and an investment recovery period of 8.8 years. The non-firm energy scenario on the other hand contributes 107% of energy consumption with a 4.4-year investment repayment duration, saving \$ 16.7 thousand. When the two scenarios are combined, the Mini-Hydropower generates 160% of the annual demand, with an additional savings of \$ 143.1 thousand and a three-year loan repayment time.

#### 4.4.4 Project Economic Viability

The primary components of the Mini-Hydropower electro-mechanical equipment require rehabilitation, according to the results in **Figure 2**, while the hydropower resources are available for the Mini-Hydropower plant to be recommissioned and updated, according to the results in Section 3.2. The project feasibility evaluation is thus based on the replacement of the entire Mini-Hydropower electro-mechanical equipment, including the operating and maintenance costs, for the reasons stated above. The capital takes into account the cost of initial equipment and other logistics, as well as their current value and evaluation.

From the economic assessment results, the Mini-Hydropower generates firm energy covering 54% of the dam load of 3.76 MWh equivalent to \$ 238.5 thousands per year, this is the cost incurred by the LHWP to keep the dam auxiliary system working every year in the absence of the Mini-Hydropower plant. For the Mini-Hydropower plant to operate again, replacement of all electrical and mechanical equipment is required with the capital of \$ 568.8 thousand for rehabilitation with the 500 kW installed capacity. On the other hand, rehabilitating the plant and increasing the plant capacity to 1000 kW, requires the capital of \$ 1.13 million.

The yearly yield of the Mini-Hydropower is then computed using firm and non-firm energy yields, with annual energy of 2.02 MWh obtained as firm yield and savings of \$128.8

thousand. Using these savings, capital will be returned in less than nine years. The project economy is viable because the costs have already been incurred. The project payback period is reduced to 4.5 years when non-firm energy is considered, making the return even quicker.

The figures utilized in this analysis were based on today's worth of money, which will either increase or drop over time, but the bargain in this viability evaluation is based only on a longterm increase in tariff, which will no longer have a financial impact on the LHWP over the plant's lifetime.

#### **4.5 Results Validation**

This section covers multiple projects related to this subject that have been recognized from various nations. In this study, the procedures used, and the outcomes gained were compared to similar projects. The following projects have been identified:

- Bigen Group has been appointed by Eskom to the Teebus Hydro power project in the Northern Cape in Gariiep, RSA. The project's goal was to conduct a feasibility study for the power station's expansion and modernization. The project's purpose was to boost the station's production to 10 MW while preserving the current civil infrastructure. Bigen offered a technical and financial pre-feasibility study that validated the project's restoration as well as the generation capacity that could be produced using existing resources [99].
- Micro-Hydropower plant of the Water Research Commission in Eastern Cape Village, South Africa. The project was the first in the RSA to employ Micro-Hydropower to provide electricity to rural settlements. The project was designed to meet the needs of 50 homes in Kwa-Madiba. [100].
- Zutari was hired as project manager for two hydropower stations in the RSA, the Marino and Sol. Plaatjie. The goal was to overcome substantial hydraulic and geotechnical obstacles while also modifying the power plant layout in order to improve power plant efficiency and output [101].
- The goal of this case study was to deploy three pole auto-reclose (TPAR) to increase system stability against transient faults in Jawa Timur and Bali [30].

#### **4.6 Summary**

The results showed the correlation between employed methods and expected outcomes as per hydropower rehabilitation literature. For the first objective to be met, the Mini-

Hydropower plant was subjected to the condition assessment filtering process, which revealed electrical components as the main culprits of damage and required the priority of rehabilitation.

In relation to the second objective, assessment proved the availability and reliability of resources for the plant to operate again and possibly plant capacity expansion. The last objective included an assessment of the stability of the plant against grid integration, which with created events showed the viability of integration without major disturbance of the plant operation, while the results showed that the Mini-Hydropower plant could operate within the stability limit when given the dam auxiliary system load only. The study economics have shown that existing Mini-Hydropower plant components replacement with similar components is economically viable and sustainable.

The next chapter concludes this report by covering the key findings of the study as well as the recommendations for further research work.

## **Chapter 5: Conclusion and Recommendations**

This chapter covers the key findings of the study and recommendations for implementation and future studies. The dissertation established here is presented in five chapters.

### **5.1. Conclusion**

Thus far, from all the data collected, data analysis and discussion throughout the study, it is established that the Katse Dam Mini-Hydropower plant is in need of rehabilitation. From the background of the study, the purpose of the construction of the Katse Dam Mini-Hydropower plant is made clear and demonstrated. However, it is identified that the intended purpose of harnessing the hydropower potential of the compensation discharge is not achieved; that is, it is not fully operational. Furthermore, the major components of the Mini-Hydropower plant (electro-mechanical) were found to be damaged.

The proposal is presented in Chapter One, and it is the window through which the study takes shape. The chapter contains the following significant characteristics: the introduction, which explains what the study is about, which is the rehabilitation of the Katse Dam MiniHydropower plant; The study's background helped to understand the state of the plant that the study sought to rehabilitate. The problem statement revealed the reason why the plant needs to be rehabilitated. The objectives of the study are another important aspect or feature of this chapter. These objectives serve as a visionary purpose for the thesis. The study's importance to both the Kingdom of Lesotho and the Republic of South Africa is clearly stated in the significance of study.

The second chapter focuses on the literature review. This is not a work of fiction set on an island. This chapter moves around different scholars in the same field in order to integrate this study into the other studies of the same principle. A need for rehabilitation is categorically stated and is significantly characterized by upgrading and uprating, which in turn characterize rehabilitation. Factors influencing hydropower rehabilitation include the conviction that rehabilitation is required. An economic appraisal indicates the purpose of a study because the study would be meaningless without it.

The third chapter is the most important part of this dissertation. To name a few, the methodology used here includes condition assessment, hydrological assessment, hydro asset trigger age of components, and visual inspection of components. The study's methods include

not only the mother body but also a directive database of the entire thesis. They are so articulate and direct in their opinions for this specific purpose. The network stability assessment and grid integration, which employ DigSilent power factory software, give this study a dignified function.

Chapter four summarizes the findings and discussions. As a result of Chapter Three, electromechanical equipment has been subjected to a variety of specific tests. The tests on these components proved beyond a shadow of a doubt that electro-mechanical equipment is damaged to some extent and thus requires rehabilitation. At this point, it is clear that the Katse Dam Mini-Hydropower plant requires rehabilitation.

The objectives are written in such a way that they allow this research three paths to follow: one, refurbishing, which entails repairing and replacing; Two, uprating, which entails increasing the generation capacity from 0.5 MW to 1 MW, and Three, synchronizing to the grid. The research reviewed strongly supports the feasibility of these three approaches in the restoration of a Mini-Hydropower plant. The methods used as criteria for assessing the state of rehabilitation equipment are the most important tools in the rehabilitation process.

The condition assessment of the electro-mechanical equipment, through the use of Hydro Asset Trigger, Visual Inspection, Equipment Testing, and Equipment Instrumentation, has strongly demonstrated that the equipment (electro-mechanical) of the major components could require the outlined tests. The results drawn from these tests have provided strong evidence that the electro-mechanical equipment of the major components is not up to the competitive standard; and therefore, the plant needs rehabilitation.

On the other hand, the assessment of hydrological resources from the historical data shows that the design flow and head duration have been exceeded for more than 96% of the time. The minimum dam load of 280 kW has a 90% exceedance with a design head of 115 m. Results further show that the maximum generation of 1 MW can be achieved for more than 51% of the time. These results give evidence of the availability of resources for continuous operation of the plant post rehabilitation and uprating at a reasonable duration. Hence, plant uprating is recommended. The project also meets the objectives of this study because there will be increased energy access, addressing the UN SDG 7, and reduced operation costs for dam auxiliary load. The project's return on investment is 9 years maximum, with an immediate saving of 54% of average annual costs.

For integrating into the grid, it is envisaged that the Katse Dam Mini-Hydropower plant's operation of a single machine is most stable when connected to the dam load only. This is where the bus voltages remain at 1 pu, rotor angle is  $0^\circ$ , electrical torque is 0.5 pu, and positive sequence active power is 0.28 MW. The machine also operates best when it remains synchronized to the grid, where the bus voltages, electrical torque, and rotor angle remain in stable mode. The worst operation of the plant occurs with a sudden loss of grid synchronism, and the maximum load remains connected to the plant. The generation of the plant collapses to 0 MW, rotor angle drops drastically, electrical torque momentarily shoots by 150%, and bus voltages drop outside the 6% permissible tolerance, resulting in a regulation violation.

## **5.2. Recommendations**

The study highlights few aspects that can be studied further or implemented to improve the current situation of the Mini Hydropower Station. The emphasis is on the electrical systems of the plant because they incurred the worst damage. The second Mini-Hydropower plant with the same capacity as the existing can be installed within the power house without any need for civil structure alteration while using provisioned space. The system can be synchronized to the grid with the emphasis placed on high load discrimination capability upon loss of the grid. The plant protection may not allow the plant to carry a load exceeding the dam auxiliary systems load for a single machine installation, while for the installation of two machines, it may be connected to both the dam and camp load as per design and may not exceed such.

The Katse Dam Mini-Hydropower plant rehabilitation is important due to its economic viability and long-term return on investment benefit to the LHWP. Implementation of this project does not require external sourcing of funds. Financing may be drawn from the already existing expenses incurred in purchasing power for running the auxiliary systems, while the operation and maintenance will remain post rehabilitation. Due to imminent gains from the project implementation, it is in the interest of this dissertation to recommend an urgent commencement of rehabilitating the Katse Dam Mini-Hydropower plant.

The study was limited to assessing the condition of electromechanical equipment, leaving civil structure condition assessment out of the picture. The component functionality tests requiring dismantling of equipment resulted in limitations that led to tests that could be done on site, hence a room for further study. Since the study was about evaluation and not

implementation, there is an area for further studies in costing, specifying, and implementation of the rehabilitation process. The study also highlighted the need for dynamic load shedding for the purpose of integrating into the grid since the Mini-Hydropower may not be able to shoulder the whole grid load upon grid loss. Implementation of dynamic load shedding is therefore an area recommended for further studies.

## References

- [1] R. K. Hitchcock, 'The Lesotho Highlands Water Project: Water, Culture, and Environmental Change', in *Water, Cultural Diversity, and Global Environmental Change*, B. R. Johnston, L. Hiwasaki, I. J. Klaver, A. Ramos Castillo, and V. Strang, Eds. Dordrecht: Springer Netherlands, 2011, pp. 319–338. doi: 10.1007/978-94-0071774-9\_23.
- [2] 'Katse Dam', *Wikipedia*. Aug. 25, 2020. Accessed: Aug. 11, 2021. [Online]. Available: [https://en.wikipedia.org/w/index.php?title=Katse\\_Dam&oldid=974854746](https://en.wikipedia.org/w/index.php?title=Katse_Dam&oldid=974854746)
- [3] 'Report on Implementation of the Instream Flow Requirements Policy', 2003. Accessed: Aug. 11, 2021. [Online]. Available: [www.http://www.lhda.org.ls/lhdaweb/Uploads/documents/IFR/Report](http://www.lhda.org.ls/lhdaweb/Uploads/documents/IFR/Report)
- [4] 'The Spotlight Volume 1 Issue 2. (full pages) .pdf', *In conversation with the CE*, Feb. 24, 2022. <https://www.lhwp.org.ls>
- [5] SOGREA, C. Bellier, G. Ninham Shand, and K. Steyn, 'Katse Dam & Appurtenant Works Mini Hydropower Station TDR Justification of the Choice of Equipment13819.pdf', LHWP, Tender Design Report 133/412, Jul. 1993.
- [6] LHWP, 'Design and Construction of the Second Malibamatso River Compensation System Katse Reservoir'. Not Published, Apr. 11, 2006.
- [7] D. C. R. MacKellar, 'The design and construction of Katse dam', p. 4, Sep. 1994.
- [8] W. J. Klunne, 'Current status and future developments of small and micro hydro in southern Africa', p. 6, 2012.
- [9] LHDA, *Katse sites electricity billing 2020*. 2020.
- [10] LHWP, 'KATSE DAM AND APPURTENANT WORKS - KATSE DAM MINIHIDRO POWER STATION GENERAL ARRANGEMENT FINAL STAGE'. Not Published, Jun. 1993.
- [11] U. N. SDGs, 'United Nations sustainable development goals', *UN Org*, 2015.
- [12] J. Goldberg and O. E. Lier, 'Rehabilitation of hydropower. An introduction to economic and technical issues', pp. 23–26, 2011.
- [13] J. Goldberg and O. E. Lier, 'Rehabilitation of hydropower. An introduction to economic and technical issues', pp. 13–14, 2011.
- [14] T. Lambert, P. Gilman, and P. Lilienthal, 'Micropower system modelling with HOMER', *Integr. Altern. Sources Energy*, vol. 1, no. 1, pp. 379–385, 2006.

- [15] *PowerFactory 2021*. Germany, 2021.
- [16] K. E. Holbert and O. Kwon, 'Reliability and economic based analysis to determine an opportune rehabilitation and modernization schedule for hydroelectric facilities', in *2011 North American Power Symposium*, Boston, MA, USA, Aug. 2011, pp. 1–6. doi: 10.1109/NAPS.2011.6024853.
- [17] 'IEEE Guide for the Rehabilitation of Hydroelectric Power Plants', IEEE. doi: 10.1109/IEEESTD.2006.99379.
- [18] J. Goldberg and O. E. Lier, 'Rehabilitation of hydropower. An introduction to economic and technical issues', pp. 19–22, 2011.
- [19] O. P. Rahi and A. K. Chandel, 'Refurbishment and uprating of hydro power plants—A literature review', *Renew. Sustain. Energy Rev.*, vol. 48, pp. 726–737, Aug. 2015, doi: 10.1016/j.rser.2015.04.033.
- [20] J. Taylor, 'Extending the operating life of hydro equipment', *Int. Water Power Dam Constr. IWPCDM*, vol. 40, no. 10, 1988.
- [21] S. Wattana and D. Sharma, 'Electricity industry reforms in Thailand: an analysis of productivity', *Int. J. Energy Sect. Manag.*, vol. 5, no. 4, pp. 494–521, Jan. 2011, doi: 10.1108/17506221111186341.
- [22] R. N. Sharma, N. Chand, V. Sharma, and D. Yadav, 'Decision support system for operation, scheduling and optimization of hydro power plant in Jammu and Kashmir region', *Renew. Sustain. Energy Rev.*, vol. 43, pp. 1099–1113, Mar. 2015, doi: 10.1016/j.rser.2014.11.005.
- [23] T. Welte, 'Deterioration and maintenance models for components in hydropower plants', 2008.
- [24] P. C. F. Erbisti, *Design of Hydraulic Gates, 2nd Edition*. CRC Press, 2014.
- [25] M. E. Arias, F. Farinosi, and D. A. Hughes, 'Future hydropower operations in the Zambezi River basin: Climate impacts and adaptation capacity', *River Res. Appl.*, vol. n/a, no. n/a, doi: 10.1002/rra.3958.
- [26] J. Fan and G. L. Morris, 'Reservoir sedimentation. II: Reservoir desiltation and longterm storage capacity', *J. Hydraul. Eng.*, vol. 118, no. 3, pp. 370–384, 1992.
- [27] F. Alam, Q. Alam, S. Reza, S. M. Khurshid-ul-Alam, K. Saleque, and H. Chowdhury, 'A Review of Hydropower Projects in Nepal', *Energy Procedia*, vol. 110, pp. 581–585, Mar. 2017, doi: 10.1016/j.egypro.2017.03.188.

- [28] G. M. Kondolf *et al.*, 'Sustainable sediment management in reservoirs and regulated rivers: Experiences from five continents', *Earths Future*, vol. 2, no. 5, pp. 256–280, 2014, doi: 10.1002/2013EF000184.
- [29] G. Wang, B. Wu, and Z.-Y. Wang, 'Sedimentation problems and management strategies of Sanmenxia Reservoir, Yellow River, China', *Water Resour. Res.*, vol. 41, no. 9, 2005, doi: 10.1029/2004WR003919.
- [30] T. Piman, T. A. Cochrane, and M. E. Arias, 'Effect of Proposed Large Dams on Water Flows and Hydropower Production in the Sekong, Sesan and Srepok Rivers of the Mekong Basin', *River Res. Appl.*, vol. 32, no. 10, pp. 2095–2108, 2016, doi: 10.1002/rra.3045.
- [31] T. B. Wild and D. P. Loucks, 'Managing flow, sediment, and hydropower regimes in the Sre Pok, Se San, and Se Kong Rivers of the Mekong basin', *Water Resour. Res.*, vol. 50, no. 6, pp. 5141–5157, 2014, doi: 10.1002/2014WR015457.
- [32] C. Aj, M. A. Salam, Q. M. Rahman, F. Wen, S. P. Ang, and W. Voon, 'Causes of transformer failures and diagnostic methods – A review', *Renew. Sustain. Energy Rev.*, vol. 82, pp. 1442–1456, Feb. 2018, doi: 10.1016/j.rser.2017.05.165.
- [33] M. Celo, R. Bualoti, and M. K. Kullolli, *The Implementation of Rehabilitation Project of Main Hydropower Plants in Albania, a way for Improvement of Operational Reliability, Safety and Environmental Standards.* 2008. doi: 10.13140/RG.2.1.3510.6723.
- [34] IEC-International Electrotechnical Commission, 'IEC 62256 (REDLINE+ STANDARD)', 2017.
- [35] 'Construction and Rehabilitation of Small Hydropower Plants in Rattanakiri Province | Our Work | JICA'. [https://www.jica.go.jp/english/our\\_work/social\\_environmental/id/asia/southeast/cambodia/c8h0vm000090vmk6.html](https://www.jica.go.jp/english/our_work/social_environmental/id/asia/southeast/cambodia/c8h0vm000090vmk6.html) (accessed Mar. 09, 2022).
- [36] A. Cateni, L. Magri, and G. Grego, 'OPTIMIZATION OF HYDRO POWER PLANTS PERFORMANCE IMPORTANCE OF REHABILITATION AND MAINTENANCE IN PARTICULAR FOR THE RUNNER PROFILES', p. 12, 2008.
- [37] A. Karakolcu, J. Erhard, and B. Wittwer, 'Best practice in rehabilitation of Pelton turbines as applied at Vermuntwerk M5', *Power MW*, vol. 30, p. 38, 2012.

- [38] A. Yazidi, H. Henao, and G.-A. Capolino, 'Broken rotor bars fault detection in squirrel cage induction machines', in *IEEE International Conference on Electric Machines and Drives, 2005.*, May 2005, pp. 741–747. doi: 10.1109/IEMDC.2005.195805.
- [39] E. David and L. Lamarre, 'Progress in DC Testing of Generator Stator Windings: Theoretical Considerations and Laboratory Tests', *IEEE Trans. Energy Convers.*, vol. 25, no. 1, pp. 49–58, Mar. 2010, doi: 10.1109/TEC.2009.2025410.
- [40] G. Stone, 'Condition monitoring and diagnostics of motor and stator windings – A review', *IEEE Trans. Dielectr. Electr. Insul.*, vol. 20, no. 6, pp. 2073–2080, Dec. 2013, doi: 10.1109/TDEI.2013.6678855.
- [41] 'IEEE Recommended Practice for Testing Insulation Resistance of Electric Machinery', IEEE. doi: 10.1109/IEEESTD.2014.6754111.
- [42] *IEC 60034-27-4 International Standard.pdf*, vol. 60034-27–4. 2018, p. 15.
- [43] E. Standards, 'IEEE 286-2000 - IEEE Recommended Practice for Measurement of Power Factor Tip-Up of Electric Machinery Stator Coil Insulation', <https://www.enstandard.eu>. <https://www.en-standard.eu/ieee-286-2000-ieee-recommended-practicefor-measurement-of-power-factor-tip-up-of-electric-machinery-stator-coil-insulation-2/> (accessed Apr. 18, 2022).
- [44] *IEC 60034-27-3 International Standard.pdf*, vol. 60034-27–3. 2016, p. 18.
- [45] N. Bartsch, 'Lubricating oil analysis according to ASTM D5185 using the Thermo Scientific iCAP 7400 ICP-OES', p. 4.
- [46] 'Standard Specification for Reagent Water'. <https://www.astm.org/d1193-06r18.html> (accessed Apr. 19, 2022).
- [47] 'Standard Test Method for Acid Number of Petroleum Products by Potentiometric Titration'. <https://www.astm.org/d0664-18e02.html> (accessed Apr. 19, 2022).
- [48] D02 Committee, 'Test Method for Acid and Base Number by Color-Indicator Titration', ASTM International. doi: 10.1520/D0974-14E02.
- [49] 'ISO 4406 Testing: Contamination Particles in Oil', p. 4.
- [50] G. Pukel, H. M. Muhr, and W. Lick, 'Transformer diagnostics: Common used and new methods', presented at the International Conference on Condition Monitoring and Diagnosis CMD, 2006.
- [51] A. K uchler, T. Leibfried, B. Breitenbauch, J. J. Alff, V. Der Houhanessian, and W. S. Zaengl, 'Transformer Insulation Diagnosis by Polarization and Depolarization Current

- Analysis', in *Internationales Wissenschaftliches Kolloquium*, Ilmenau: Technische Universität Ilmenau, 2003. [Online]. Available: <https://opus4.kobv.de/opus4-fhws/frontdoor/index/index/docId/1162>
- [52] M. Duval and A. dePabla, 'Interpretation of gas-in-oil analysis using new IEC publication 60599 and IEC TC 10 databases', *IEEE Electr. Insul. Mag.*, vol. 17, no. 2, pp. 31–41, Mar. 2001, doi: 10.1109/57.917529.
- [53] J. Dukarm, Z. Draper, and T. Piotrowski, 'Diagnostic Simplexes for Dissolved-Gas Analysis', *Energies*, vol. 13, no. 23, p. 6459, Dec. 2020, doi: 10.3390/en13236459.
- [54] G. J. Pukel, H. M. Muhr, and W. Lick, 'Transformer diagnostics: Common used and new methods', p. 4.
- [55] S. Ward, 'Evaluating transformer condition using DGA oil analysis', Nov. 2003, pp. 463–468. doi: 10.1109/CEIDP.2003.1254893.
- [56] I. B. M. Taha, Sherif. S. M. Ghoneim, and H. G. Zaini, 'Improvement of Rogers four ratios and IEC Code methods for transformer fault diagnosis based on Dissolved Gas Analysis', in *2015 North American Power Symposium (NAPS)*, Oct. 2015, pp. 1–5. doi: 10.1109/NAPS.2015.7335098.
- [57] A. KÜchler, T. Leibfried, B. Breitenbauch, J. J. Alff, V. Der Houhanessian, and W. S. Zaengl, 'Transformer insulation diagnosis by polarization and depolarization current analysis', 2003.
- [58] J. Fabre and A. Pichon, 'Deteriorating processes and products of paper in oil. Application to transformers', *CIGRÉ Pap.*, vol. 137, p. 18, 1960.
- [59] A. E. B. Abu-Elanien and M. M. A. Salama, 'Evaluation of transformer health condition using reduced number of tests', *Electr. Eng.*, vol. 101, no. 2, pp. 357–368, Jun. 2019, doi: 10.1007/s00202-019-00785-x.
- [60] O. P. Rahi and A. Kumar, 'Economic analysis for refurbishment and uprating of hydro power plants', *Renew. Energy*, vol. 86, pp. 1197–1204, Feb. 2016, doi: 10.1016/j.renene.2015.09.044.
- [61] O. P. Rahi and G. Kumar, 'Simulation studies for refurbishment and uprating of hydro power plants', in *2014 IEEE PES General Meeting | Conference & Exposition*, National Harbor, MD, USA, Jul. 2014, pp. 1–5. doi: 10.1109/PESGM.2014.6939122.
- [62] A. Coulier, *Multiscale Modeling in Systems Biology: Methods and Perspectives*, vol. 2051. Acta Universitatis Upsaliensis, 2021. doi: 10.33063/diva-442412.

- [63] D. Xie, D. Zang, and P. Gao, 'Research on Stability of the Power System', *IOP Conf. Ser. Earth Environ. Sci.*, vol. 81, p. 012163, Aug. 2017, doi: 10.1088/17551315/81/1/012163.
- [64] G. Cao, L. Chen, and K. Aihara, 'Power System Voltage Stability Assessment Based on Branch Active Powers', *IEEE Trans. Power Syst.*, vol. 30, no. 2, pp. 989–996, Mar. 2015, doi: 10.1109/TPWRS.2014.2329731.
- [65] 'Contribution to Bulk System Control and Stability by Distributed Energy Resources connected at Distribution Network'.  
<https://resourcecenter.ieee-pes.org/publications/technical-reports/PESTRPDFMRH0022.html> (accessed Apr. 04, 2022).
- [66] F. Blaabjerg, R. Teodorescu, M. Liserre, and A. V. Timbus, 'Overview of Control and Grid Synchronization for Distributed Power Generation Systems', *IEEE Trans. Ind. Electron.*, vol. 53, no. 5, pp. 1398–1409, Oct. 2006, doi: 10.1109/TIE.2006.881997.
- [67] N. Hatziargyriou *et al.*, 'Definition and Classification of Power System Stability – Revisited & Extended', *IEEE Trans. Power Syst.*, vol. 36, no. 4, pp. 3271–3281, Jul. 2021, doi: 10.1109/TPWRS.2020.3041774.
- [68] P. Kundur *et al.*, 'Definition and classification of power system stability IEEE/CIGRE joint task force on stability terms and definitions', *IEEE Trans. Power Syst.*, vol. 19, no. 3, pp. 1387–1401, Aug. 2004, doi: 10.1109/TPWRS.2004.825981.
- [69] O. G. I. Okwe Gerald Ibe and A. I. Onyema, 'Concepts of Reactive Power Control and Voltage Stability Methods in Power System Network', *IOSR J. Comput. Eng.*, vol. 11, no. 2, pp. 15–25, 2013, doi: 10.9790/0661-1121525.
- [70] IEEE/CIGRE Joint Task Force on Stability Terms and Definitions, 'Definition and Classification of Power System Stability IEEE/CIGRE Joint Task Force on Stability Terms and Definitions', *IEEE Trans. Power Syst.*, vol. 19, no. 3, pp. 1387–1401, Aug. 2004, doi: 10.1109/TPWRS.2004.825981.
- [71] P. Kundur, *power system stability and control*. McGraw-Hill, Inc., 1994. [Online]. Available: [www.elcom-hu.com](http://www.elcom-hu.com)
- [72] J. Paserba, 'Analysis and control of power system oscillation', *CIGRE Spec. Publ.*, vol. 38, no. 07, pp. 6–14, 1996.
- [73] J. Paserba, J. Sanchez-Gasca, P. Kundur, E. Larsen, and C. Concordia, 'Small signal stability and power system oscillations', in *Electric power engineering handbook*, IEEE Press, 2001, pp. 20–34.

- [74] T. van Cutsem and C. Vournas, 'Load Aspects', in *Voltage stability of electric power systems*, Springer, 1998, pp. 93–133.
- [75] F.-F. Li, C. A. Shoemaker, J.-H. Wei and X.-D. Fu, 'Estimating maximal annual energy given heterogeneous hydropower generating units with application to the Three Gorges system', *Journal of Water Resources Planning and Management*, vol. 139, no. 3, pp. 265–276, 2013.
- [76] F.-F. Li, H.-R. Wang, Z.-G. Wu and J. Qiu, 'Maximizing both the firm power and power generation of hydropower station considering the ecological requirement in fish spawning season', *Energy Strategy Reviews*, vol. 30, pp. 100496, Jul. 2020.
- [77] C. Obialor, O. Okeke, A. Onunkwo, and V. Fagorite, 'RESERVOIR SEDIMENTATION: CAUSES, EFFECTS AND MITIGATION', pp. 2488–9849, Oct. 2019.
- [78] C. J. Sloff, 'Reservoir sedimentation; A literature survey', *Commun. Hydraul. Geotech. Eng. No 1991-02*, 1991.
- [79] L. J. Puthumana and J. A. Jaleel, 'Performance evaluation of AGC of SHP with multiarea power system', in *2011 International Conference on Power and Energy Systems*, Dec. 2011, pp. 1–5. doi: 10.1109/ICPES.2011.6156666.
- [80] M. Istad, M. Runde, and A. Nysveen, 'A Review of Results From Thermal Cycling Tests of Hydrogenerator Stator Windings', *IEEE Trans. Energy Convers.*, vol. 26, no. 3, pp. 890–903, Sep. 2011, doi: 10.1109/TEC.2011.2127479.
- [81] J. Goldberg and O. Espeseth Lier, 'Rehabilitation of hydropower: an introduction to economic and technical issues', 2011.
- [82] A. Cateni, L. Magri, and G. Grego, 'Optimization of Hydro Power Plants Performance—Importance of rehabilitation and maintenance in particular for the runner profiles', presented at the Proceedings of the 7th international conference on hydraulic efficiency measurements. Milan, Italy, 2008.
- [83] 'IEEE Guide for the Rewind of Synchronous Generators, 50 Hz and 60 Hz, Rated 1 MVA and Above', *IEEE Std 1665-2009*, pp. 1–98, Feb. 2010, doi: 10.1109/IEEESTD.2009.5415857.
- [84] 'IEEE Recommended Practice for Testing Insulation Resistance of Rotating Machinery', *IEEE Std 43-2000*, pp. 1–28, Mar. 2000, doi: 10.1109/IEEESTD.2000.91301.

- [85] M. Davies, 'Dielectric absorption', *Q. Rev. Chem. Soc.*, vol. 8, no. 3, pp. 250–278, Jan. 1954, doi: 10.1039/QR9540800250.
- [86] A. H. Price, 'DIELECTRIC ABSORPTION OF SOME INTRAMOLECULAR HYDROGEN BONDED PHENOLS IN SOLUTION', *ACS Publications*, May 01, 2002. <https://pubs.acs.org/doi/pdf/10.1021/j100839a020> (accessed Apr. 21, 2022).
- [87] Z. A. A. Zarim and I. A. B. A. Ghani, 'The effect of water tree and partial discharge defects in XLPE cables to the dielectric absorption ratio', in *2016 IEEE International Conference on Power and Energy (PECon)*, Nov. 2016, pp. 606–609. doi: 10.1109/PECON.2016.7951632.
- [88] 'IEEE Recommended Practice for Quality Control Testing of External Discharges on Stator Coils, Bars, and Windings', IEEE. doi: 10.1109/IEEESTD.2012.6365722.
- [89] 'Katse Dam IFR Releases Scheduling Model - 2021.xls'. Not Published, 2021.
- [90] J. ADEBISI, *FUNDAMENTALS OF COMPUTER STUDIES*. 2013.
- [91] F. M. Gonzalez-Longatt and J. L. Rueda, *PowerFactory Applications for Power System Analysis*. Springer, 2014.
- [92] H. Khoshkhoo and A. Parizad, 'Dynamic Stability Improvement of Islanded Power Plant by Smart Power Management System: Implementation of PMS Logic', in *Advanced Smart Grid Functionalities Based on PowerFactory*, F. Gonzalez-Longatt and J. L. Rueda Torres, Eds. Cham: Springer International Publishing, 2018, pp. 125–151. doi: 10.1007/978-3-319-50532-9\_6.
- [93] Rayes Ahmad Lone, 'Power System Stability Analysis of Small Scale Hydro Plant and its Enhancement using PI Controller', 2018, doi: 10.13140/RG.2.2.15670.86085.
- [94] 'Compensation Policy'. Lesotho Highlands Development Authority, 1997. [Online]. Available: <http://www.lhwp.org.ls>
- [95] 'Value of 1995 South African Rand today - Inflation Calculator'. <https://www.inflationtool.com/south-african-rand/1995-to-present-value> (accessed May 07, 2022).
- [96] 'Mini Hydropower Station Equipment Tests Certificates'. Not Published, Jan. 1995.
- [97] Z. Girma, 'Techno-Economic Feasibility of Small Scale Hydropower in Ethiopia: The Case of the Kulfo River, in Southern Ethiopia', *J. Renew. Energy*, vol. 2016, p. e8037892, Mar. 2016, doi: 10.1155/2016/8037892.
- [98] L. G. F. Westin, L. R. Conceição, E. C. Bortoni, A. L. M. Marcato, C. B. de M. Ribeiro, and L. de M. Honório, 'Evaluating the Impact of Streamflow Rating Curve Precision on

Firm Energy of Hydropower Plants', *Water*, vol. 13, no. 8, Art. no. 8, Jan. 2021, doi: 10.3390/w13081016.

- [99] 'Teebus Hydro Power Station - Bigen Group Energy Project'. <https://bigengroup.com/project/teebus-hydro-power-station/> (accessed Apr. 26, 2022).
- [100] 'Micro-hydropower lights up an Eastern Cape village - The Mail & Guardian'. <https://mg.co.za/environment/2021-06-20-micro-hydropower-lights-up-an-easterncape-village/> (accessed Apr. 26, 2022).
- [101] 'Zutari projects | Bethlehem hydro project | South Africa'. <https://www.zutari.com/project/bethlehem-hydro-project/> (accessed Apr. 26, 2022).